



Coherent Detection WDM Optical OFDM System

Manpreet Singh¹, Karamjit Kaur²

Student, University College of Engineering, Punjabi University, Patiala, India¹.

Assistant Professor, University College of Engineering, Punjabi University, Patiala, India².

Abstract: Orthogonal frequency division multiplexing (OFDM) is an attractive modulation format that recently received a lot of attention in the fiber-optic community. The main advantage of optical OFDM is that it can cope with virtually unlimited amount of inter symbol interference (ISI). In high-speed optical transmission systems, ISI is caused for instance by chromatic dispersion and it is serious issue in long-haul systems whose bit rate is higher. High order dispersion such as a third-order and higher-order dispersion effects are not fully compensated using the traditional dispersion compensating devices such as Dispersion compensating fiber (DCF), Optical Filters etc. Thus the received signals at the receiver end would be distorted dramatically, even if only a small outside effect affects the transmission link. The Phase modulator system is proposed in this work at the receiver end to recover higher-order dispersion which would not be compensated by DCF fiber and Optical Filters.

Keywords: Bit error Rate, Coherent Detection, Phase Modulator, Optical OFDM, Third order dispersion.

1. INTRODUCTION

Orthogonal frequency division multiplexing (OFDM) has been widely employed into numerous digital standards for broad-range of applications such as digital audio/video broadcasting and wireline/wireless communication systems [1]. Many key merits of the OFDM techniques have been studied and proven in the communications industry. Firstly, the frequency spectra of OFDM subcarriers are partially overlapped, resulting in high spectral efficiency. Secondly, the channel dispersion of the transmission system is easily estimated and removed, and thirdly, the signal processing in the OFDM transceiver can take advantage of the efficient algorithm of FFT/IFFT with less complexity. Recently, an equivalent optical-domain multi-carrier format, called coherent optical OFDM (CO-OFDM) has been proposed for long haul transmission [2]. Dispersion-compensating fibre is one of the dispersion management methods to recover signals after a period of distance. However, dispersion slope compensation and wavelength division multiplexing transmission is very hard to fully compensate especially for very high data rate signals. Therefore, the equalizer system which i.e. phase modulator is used before receiver. The equalizer is used to compensate not only group velocity dispersion, but also for third order dispersion [3,4].

The distribution of power among the longitudinal modes of the laser fluctuates and, as a consequence of the chromatic dispersion in the fiber, causes an amplitude fluctuation of the signal at the decision circuit in the receiver. The effect is in essence a pulse-delay fluctuation, and the error rate cannot be reduced by increasing the received signal power. By using the proposed Dispersion equalizer, the zero dispersion can be shifted to the

minimum-loss window at 1550nm, while the dispersive effects do not suppress completely in the operating wavelength region because of the non-zero dispersion slope. Coherent Optical OFDM (CO-OFDM) is considered an enabling technology of the next generation optical communication system [5]. As a coherent system, the CO-OFDM system maintains both signal amplitude and phase [6], thus increasing bandwidth utilization. The coherent optical communication system makes full compensation of chromatic dispersion, after optical/electrical conversion, possible. Optical frequency division multiplexing (OFDM) is an attractive modulation scheme that recently received a lot of attention in the fiber optic community. OFDM is a multicarrier transmission technique where a data stream is carried with many lower rate subcarrier tones that is high bit rate data stream is divided into several low bit rates streams that are simultaneously modulated onto orthogonal subcarriers. The OFDM modulation scheme also leads to a high spectral efficiency because of its partially overlapping subcarriers [5]. Moreover, the cyclic prefix code of the COOFDM system makes the system more resistant to inter-symbol interference caused by chromatic dispersion and polarization mode dispersion (PMD) [5, 7].

2. SYSTEM SETUP

The optical transmission link with & without equalizer compensation by using single channel CO-OFDM system is setup by using a commercial fiber optics system simulation tool, OptiSystem™. It has been used by many researchers to simulate the fiber nonlinearity and dispersion effects in optical communication systems [7][8].



Simulation setting takes most key optical communication system/component parameters into account including fiber nonlinearity, noise, dispersion, etc. A generic CO-OFDM system includes five basic functional blocks: OFDM transmitter, RF to optical (RTO) up-converter, optical link, optical to RF (OTR) down-converter, and OFDM receiver. Figure 1 demonstrates a 10 Gbps coherent 512-subcarrier 4-QAM OFDM system; however the input data for the OFDM modulator can have different modulation formats such as BPSK, QPSK, QAM, etc. At the transmission block, both modulation and multiplexing are achieved digitally using an inverse fast Fourier transform (IFFT). The subcarrier frequencies are mathematically orthogonal over one OFDM symbol period. A Continuous Wave laser and two Mach-Zehnder modulators are used to up-convert the RF data to the optical domain. The signal is then propagated through the optical link and becomes degraded due to fiber impairments. A coherent receiver with a local oscillator is used to down-convert the data to the RF domain, and finally data is demodulated and sent to the detector and decoder for BER measurements.

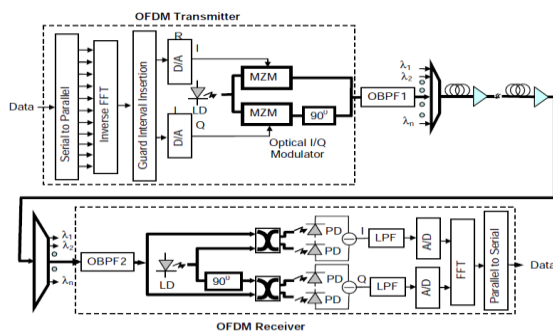

Fig 1: Optical OFDM system with Mach-Zehnder modulator

The data transmission bit rate is 10 Gbps. On the transmitter side, a bit stream is generated using a pseudo random binary sequence generator, and the data is mapped by a 4-QAM encoder. The information stream is further passed into 512 low speed parallel data subcarriers and processed by the IFFT processor. Cyclic prefix is added to ensure a correct data recovery. The Mach-Zehnder modulator is used to convert electrical signals to optical signals. The laser line width is set at 0.15MHz, with adjustable launch power. The frequency of the carrier wave is set at 193.1THz. The optical channel consists of 2 spans of 60 km single mode fiber (SMF), with attenuation = 0.2dB/km, dispersion = 16 ps/nm/km. The local oscillator (LO) laser is assumed to be perfectly aligned with power set at -2dBm and line width equals to 0.15 MHz. The I/Q components of the OFDM signal is recovered by a 90 degree optical hybrid and two pairs of photo-detectors. Photo-detector noise, such as thermal, shot noise, dark current and ASE noise are included in the simulation. The converted OFDM RF signal is demodulated using FFT processor and the guarding interval is removed. The obtained signals are fed into a 4-QAM decoder. Transmission bits are collected and bit

error ratio (BER) is calculated for both the system having equalizer and compared at the end of the receiver.

3. SYSTEM DESIGN USING OPTISYSTEM

Optical OFDM based on coherent detection is depicts in Figure 2, 3 and 4.

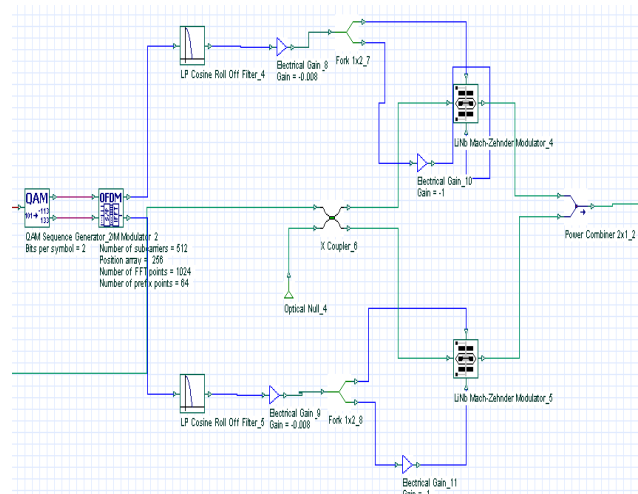

Figure 2: Optical OFDM Transmitter

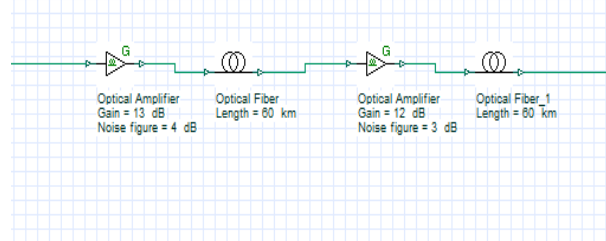

Figure 3: Optical Transmission Link.

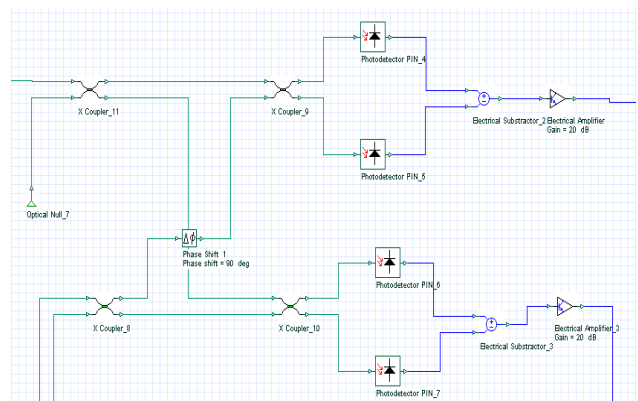

Figure 4: Coherent Detection of Optical OFDM

In OOFDM system, the transmitter model is consisted of two parts, the first part is the radio frequency (RF) transmitter and the second one is optical transmitter. The role of the optical transmitter is to convert the electrical signal into optical form, and launch the resulting optical signal into the optical fiber and also can called RF



to optical up converter (RTO). The optical transmitter consists of the following components, optical source, electrical pulse generator and optical modulator as shown in Figure 2.

The transmission link as shown in Figure 3 part is consisted of optical fiber with length of 60 km and attenuation 0.2 dB/km, which work as transmission media, optical amplifier to amplify the weak signals and optical signal with the same window of laser, this transmission link is repeated twice.

The receiver model of this OOFDM system is consisted of two parts, the first is optical receiver, and the second one is RF receiver as shown in figure 4. The optical receiver is consisted of two blocks and also called optical to RF down converter (OTR). When the optical signal sent from laser to receiver by fiber the first block is received the signal is photodetector, which is Positive Intrinsic Negative detector with responsivity 1 A/W.

After the optical signal converted to electrical signal and all noise is eliminated, the signal will be demodulated at the same RF frequency which was modulated, then the signal will demodulated with OFDM demodulator to extract the symbols and then decoded to get the original bits.

4. COHERENT WDM OPTICAL OFDM SYSTEM DESIGN

Because of huge advantages of using Optiwave simulation software Ver.10.0 for running simulation, this platform has been chosen to build a 40 Gb/s transmitted signal with and without equalizer. The schematic diagram for the proposed system of a 120 km transmission link including SMF-DCF fibers is described in Figure 5. Initially, four 10 Gb/s Transmitter are used and these four 10 Gb/s signals are multiplexed by using WDM technique. Optical Amplifier system is used for one-span 60 km transmission fiber. Furthermore, bit-error-rate is also calculated when equalizer is installed in order to prove the critical improvement when equalizer is used in the system. To investigate the limitation of 40 Gb/s system with and without equalizer by increasing number of spans means that transmission length would be increased for each situation. Constellation diagrams are also investigated for each situation at a value of receive power of approximately -40 dbm. From those constellation diagrams, significant improvement would be seen from transmitted system with equalizer, especially when the fiber length is increased.

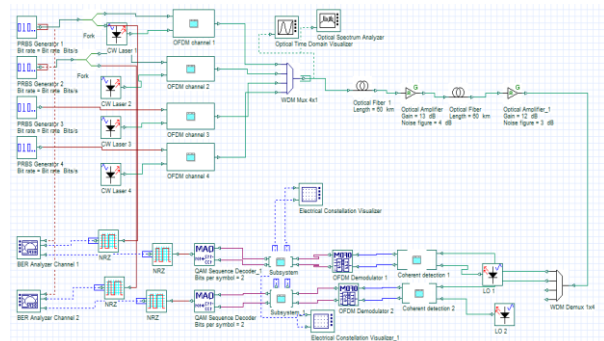

Figure 5: Coherent WDM Optical OFDM system

5. RESULTS AND DISCUSSIONS

The system is analyzed and the performance of system is checked with & without equalizers at 10 Gbps. The result for the transmitter part which is in electrical, frequency and optical domain was shown in the figures below from Figure 6 to Figure 10, these results shows the constellation diagram for 4 QAM encoder output, frequency domain OFDM signal, the signal after MZM modulator and the optical signal frequency domain in fiber link media.

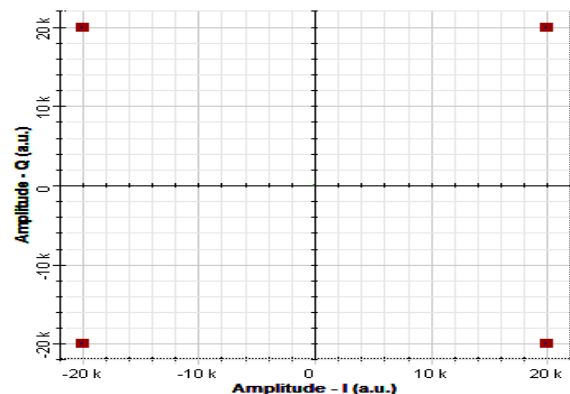

Figure6: 4 QAM Encoder Constellation Diagram

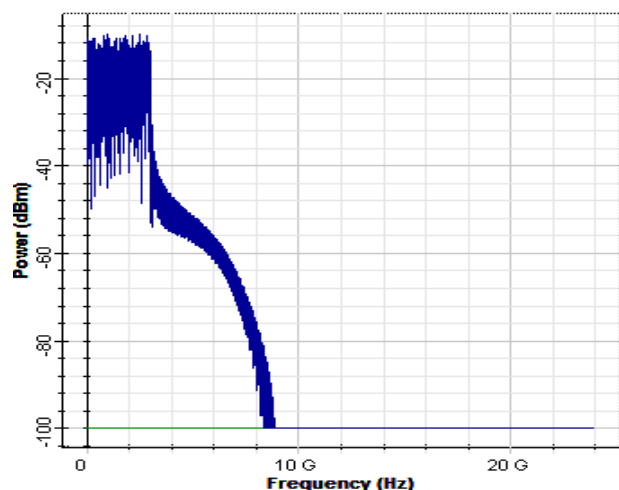

Figure 7: Modulated OFDM Signal in Frequency Domain for each OFDM Channel.



Figure 8 shows the Coherent Optical OFDM Signal (combination of each OFDM channel) after WDM MUX as shown in figure 5. This signal is Optical in nature with 193.05, 193.1, 193.15, 193.2 (all in THz) frequencies of OFDM channel 1,2,3,4 respectively.

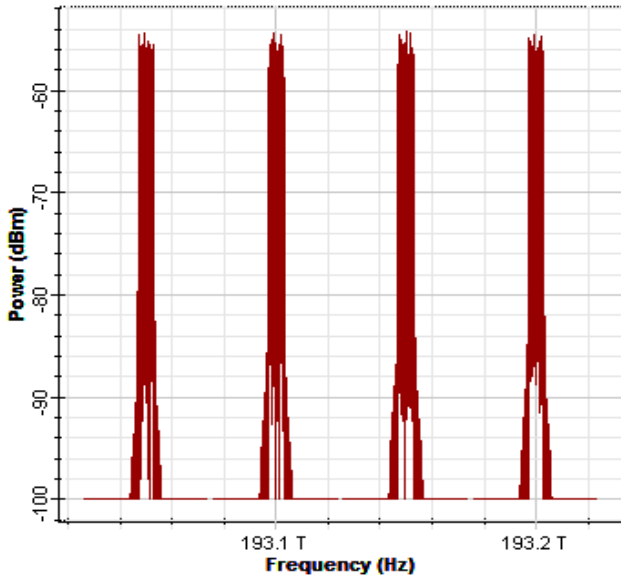

Figure 8: (a) Signal after WDM MUX.

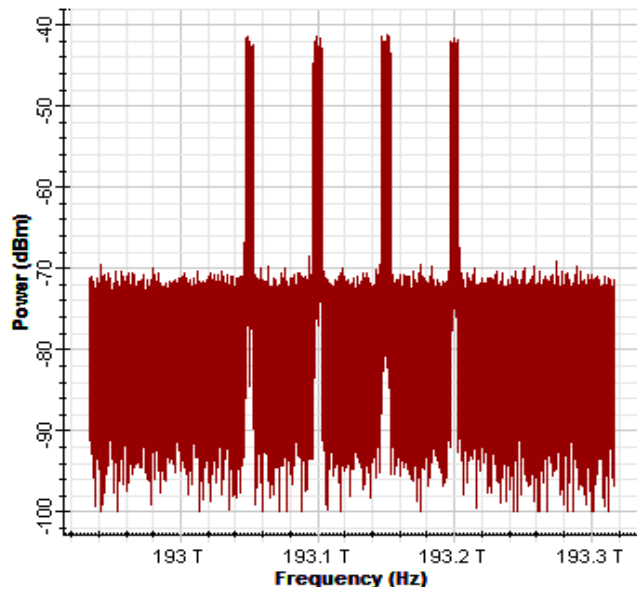
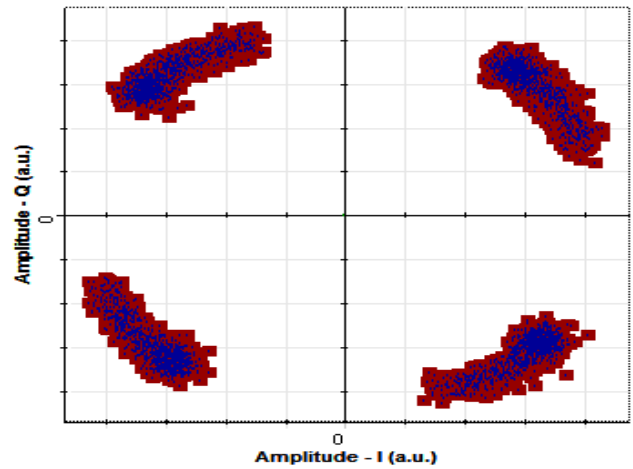
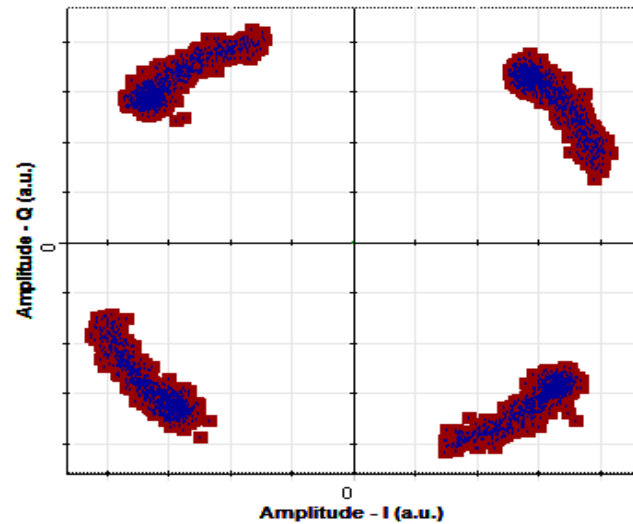

Figure 8: (b) Optical signal in the Fiber

After the clarified RF OFDM signal is achieved at OFDM demodulator and the demodulation operation is done, the output of the demodulator will analyze to achieve desired value of BER. At first BER is calculated for system having second order dispersion and secondly the BER is calculated for Third order dispersion also. The performance of Optical filters will also be compared with Phase Modulator.



(a) Without equalizer



(a) With equalizer

Figure 8: Final 4QAM Decoder constellation diagram

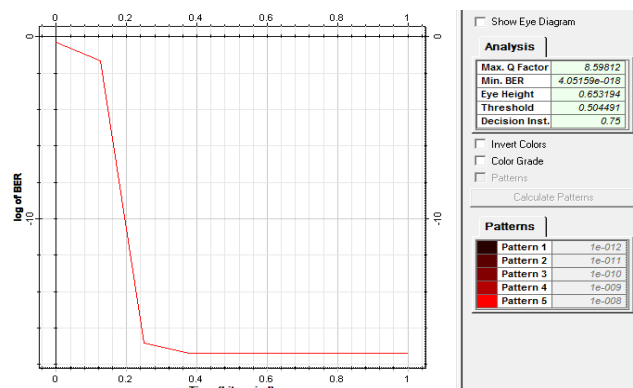

Figure 9: Minimum BER with Phase Modulator

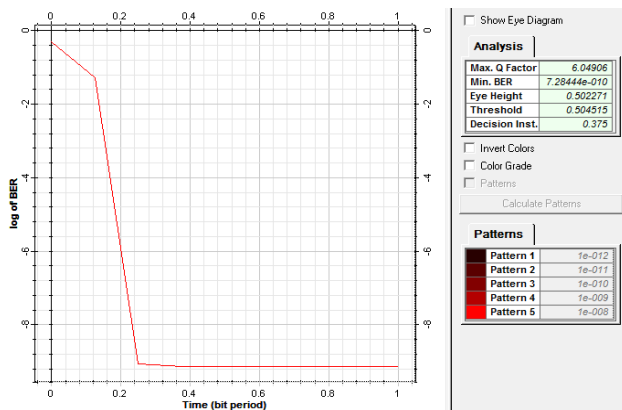

Figure 10: Minimum BER with Optical filter

Comparison of Results:

Transmission Configuration used	MIN BER	Q FACTOR	EYE HEIGHT
Without compensators	1.5×10^{-9}	5.92	0.49
With Optical Filters	7.2×10^{-10}	6.04	0.50
With Phase Modulator	4.05×10^{-18}	8.05	0.65

6. CONCLUSION

The approach of this work is to compensate higher order dispersion of Coherent detection WDM Optical OFDM system using Phase Modulator and compare the performance of Phase modulator with optical filters.

The final constellation diagram shows the increase in distance between symbols because of equalizer.

The BER of system using phase modulator reduces considerably as compared to the system having Optical filter. The results are also shown in terms of Q factor.

The Phase of the phase modulator can be varied to achieve best value of BER.

REFERENCES

- [1]. S. Hara and R. Prasad, *Multicarrier Techniques for 4G Mobile Communications*, (Artech House, Boston, 2003).
- [2]. W. Shieh and C. Athaudage, "Coherent optical orthogonal frequency division multiplexing," *Electron. Lett.* **42**, 587 – 588 (2006).
- [3]. Hellstrom, E., H. Sunnerud, et al. "Third-order dispersion compensation using a phase modulator. *Journal of lightwave Technology* 21(5):1188-97, 2003.
- [4]. Yamamoto, T., et al "Third- and fourth-order active dispersion compensation with a phase modulator in a terabit-per second optical time-division multiplexing transmission, *optic letters*, 11 (9):647-49.
- [5]. W. Shieh, H. Bao, and Y. Tang, "Coherent optical OFDM: Theory and design," *Opt. Exp.*, vol. 16, pp. 842–859, Jan. 2008.
- [6]. E. Ip, A. P. T. Lau, D. J. F. Barros, and J. M. Kahn, "Coherent detection in optical fiber systems," *Opt. Exp.*, vol. 16, pp. 753–791, Jan. 2008.
- [7]. G. P. Agrawal, "Nonlinear Fiber Optics, Second Edition", Academic Press, San Diego, USA, (1995) Chap. 10.