

Performance Analysis of FBG DEMUX based WDM System by Varying Chirp Functions and Data Rates at Different Electrical Filters

N Sangeetha¹, Rashi Garg², Surabhi Purwar³, Akshita Singh⁴

Assistant Professor, SENSE, VIT University, Vellore, India ¹

UG Student, SENSE, VIT University, Vellore, India ^{2,3,4}

Abstract: Wavelength Division Multiplexing greatly enhances the capacity of the optical networks and is needed to satisfy the increasing demand for high bandwidths. This paper discusses the application of a Demultiplexer (DEMUX) based on Fiber Bragg Grating (FBG) with the help of electrical filters, reducing the bit error rate and enhancing the quality factor of the received optical signal in a WDM network. To simulate WDM based passive optical networks for a wavelength spacing of 25GHz Gaussian apodized FBGs are used. The simulation of a chirped FBG DEMUX is described with various electrical filters at data rates of 1.25 Gbps and 2.5 Gbps. The Q-factor and BER values for linear, quadratic and square root chirp functions are compared at different data rates. Based on the results, FBG based DEMUX with the best performing filters are identified at the different data rates. All simulations were performed in Optisystem 7.0.

Keywords: Wavelength Division Multiplexing, Fiber Bragg Grating, Electrical Filters, Demultiplexer, Bit error rate, Quality factor.

I. INTRODUCTION

Information is sent from one place to another in the form of light pulses. Optical networks are adopted for efficient accommodation of traffic. The requirements such as high data rate and large number of transmission channels have made today's fiber optic data systems very complex, expensive and lossy. In today's world, the desire to communicate with ease has stimulated the development of broadband based communication services. Increasing number of users and bandwidth demands has brought rapid evolution of high speed access networks for enhancing the Quality of Service (QoS) and reducing the delays provided to the user by the service providers. For better functionality and cost effective implementation new architecture is required for technologies. Optical Networks provide higher bandwidth than copper based networks. PONs has low signal integrity and security. They are wavelength independent and low cost optical schemes. Increasing demand of communication requires robust and efficient optical system. Due to possibility of high transmission capacity WDM system is progressing. Wavelength Division Multiplexed optical networks are developed to support multiple signals with different frequencies or wavelengths in order to increase security and integrity of data in single fibre. They are used for achieving high system capacity and for effective usage of bandwidth. One of the applications of WDM can be found in Passive Optical Networks (PON). Starting from the early 1990s, the internet boom pushed service providers to find a method to increase the capacity on their network in the most economical way, which is when WDM devices were invented. However, due to lack of an available market these ideas could not be commercialized [2]. But in today's world WDM based PONs are extensively commercialized. Dense WDM (DWDM) technique utilizes a channel spacing of 100-200 GHz between

successive users but Ultra Dense WDM (UDWDM) scheme has reduced channel spacing to 25-50 GHz, thereby increasing the capacity of the existing DWDM networks. Multiplexers (MUX) and De-multiplexers (DEMUX) are very crucial in optical networks and they support multiple users. Chromatic dispersion can cause significant distortions in the optical pulses in optical fibers during transmission. For enhancing the quality of transmission dispersion compensators are required. Optical Fiber Bragg Gratings (FBG) are generally used to compensate dispersion. A Fiber Bragg Grating is a reflective device etched into the optical fiber by irradiating the fiber with ultraviolet radiation. The reflected spectrum broadens as the reflected wavelength changes with the grating period. Advantages of fiber gratings over other technologies include fiber geometry, low insertion loss, high return loss or extinction, and potentially low cost [4]. Chirped FBGs can be used for dispersion compensation. When there is a requirement of low level side lobe then quadratic chirp functions are implemented.[5]Application of linear chirped fibre grating is in tunable dispersion slope compensator to control the dispersion slope[6].FBGs based DEMUX will require fewer gratings per channel. It can be easily extended to 16 or 32 channel systems and will be very cost effective. Other aspect in communication media is bit errors in digital data transmission. To this fact Optical communication is not an exception. There is a possibility of data corruption in the optical network components. Filters are used to decrease Bit Error Rate (BER) and to enhance the Quality factor (Q-factor). The QoS of optical filters is lower as compared to electrical filters but the use of optical filters is convenient and cost effective. Yet when the priority is QoS, despite its high cost of conversion hardware electrical filters are preferred over optical filters. The simulation of the spectral response

and efficiency of such a de-multiplexer with linear, quadratic and square root chirp functions are discussed with performance analysis of commonly used electrical filters in the following sections. Results are discussed using Optisystem 7.0.

II. THEORY

A. Fiber Bragg Grating

A Fiber Bragg Grating (FBG) is a distributor bragg reflector in which the refractive index of the core changes periodically along the short length period known as lambda. When light with many wavelengths is launched into a FBG one particular wavelength infest the grating period and this wavelength is reflected back to the input end. All other wavelengths pass through the fiber as they do not infest with the grating period. This makes FBG reflect a particular wavelength and transmit all others. Each wavelength of light travels a differential distance into the waveguide grating [3]. This effect arises because of the continuously changing period along the grating length. Each wavelength component will travel into the waveguide grating and be reflected at the point where the local grating period is matched with the wavelength of light.

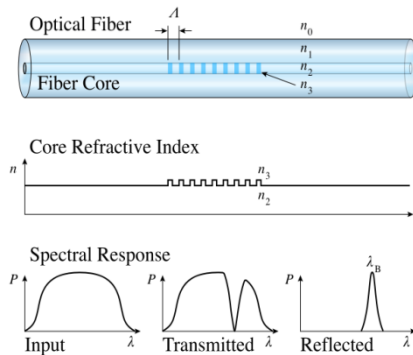

Fig.1 Fiber Bragg Grating

The bragg wavelength which is reflected back by the FBG can be calculated by:

$$\lambda_B = 2n_{\text{eff}}\Lambda$$

Where n_{eff} is effective refractive index and Λ is the period of the grating.

The bandwidth of bragg grating is defined by:

$$\Delta\lambda = \lambda_B \{2\delta n_o / \Pi\}$$

The grating period of the FBG can be uniform, graded, localized or distributed. To increase side-lobe suppression and to achieve the required discrimination between adjacent wavelength channels in WDM systems, fiber gratings are apodized[7]. This is generally achieved by altering the refractive index of the optical fiber at both ends. The reflectivity of an apodized grating can be calculated by defining an effective length L_{eff} .

$$q_{\text{max}}L_{\text{eff}} = \int q(z)dz$$

For comparing grating for different apodizations, the quantity (q) must be same for each. A Bragg grating can compensate for the chromatic dispersion when it is linearly chirped i.e. when its period varies linearly along the z axis according to the following equation:
 $\Lambda(z) = \Lambda_o + az$

Higher order dispersion compensation can also be taken into account by using a non-linearly chirped Bragg grating having a period $\Lambda(z)$ which is given by:
 $\Lambda(z) = \Lambda_o + az + \beta z^2 + \gamma z^3 + \dots$

The grating is apodized along its length to eliminate group delay ripple as well as ripple within the pass band. The local period of the grating device at any location, z is given by:

$$\Lambda(z) = \Lambda_{\text{ave}} + \Delta\Lambda * z^2$$

Where $\Lambda_{\text{ave}} = 295 \text{ nm}$ to ensure an operating wavelength close to 1550nm and $\Delta\Lambda$ describes the total variation in the grating period within the device. Therefore, the chirp at any point in the grating varies quadratically with z. It should be noted that z is a dimensionless parameter describing the distance between the start of the grating and the location within the grating[1].

B. Filters

A Bessel low pass filter is characterized by its transfer function [8]:

$$H(s) = \frac{\theta_n(0)}{\theta_n(s/\omega_0)}$$

Where $\theta_n(s)$ is a reverse Bessel polynomial, from which the filter gets its name and ω_0 is a frequency chosen to give the desired cut-off frequency. The filter has a low-frequency group delay of $1/\omega_0$.

The reverse Bessel polynomials are given by:

$$\theta_n(s) = \sum_{k=0}^n a_k s^k,$$

Where,

$$a_k = \frac{(2n-k)!}{2^{n-k} k! (n-k)!} \quad k = 0, 1, \dots, n.$$

The transfer function of Butterworth can be written in terms of these poles as

$$H(s) = \frac{G_0}{\prod_{k=1}^n (s - s_k) / \omega_c}$$

The denominator is a Butterworth polynomial in s where,

$$s_k = \omega_c e^{\frac{j(2k+n-1)\pi}{2n}} \quad k = 1, 2, 3, \dots, n.$$

The type II Chebyshev low-pass filter is also known as inverse Chebyshev. This type is less common because it does not roll off as fast as type I, and requires more components. It has no ripple in the pass band, but does have equi-ripple in the stop band. The gain is:

$$G_n(\omega, \omega_0) = \frac{1}{\sqrt{1 + \varepsilon^2 T_n^2(\omega/\omega_0)}}.$$

The transfer function of RC filter is given as:

$$H = |H(\omega)| = \frac{\omega/\omega_0}{\sqrt{1 + (\omega/\omega_0)^2}}$$

The frequency response of Gaussian filter is given by:

$$\hat{g}(f) = e^{-\frac{f^2}{2\sigma_f^2}}$$

For $\hat{g}(f)$ it can be shown that the product of the standard deviation and the standard deviation in the frequency domain is given by:

$$\sigma \cdot \sigma_f = \frac{1}{2\pi}$$

Where, the standard deviations are expressed in their physical units..

The frequency-domain description of Cosine Roll off filter is a piecewise function given by:

$$H(f) = \begin{cases} T, & |f| \leq \frac{1-\beta}{2T} \\ \frac{T}{2} \left[1 + \cos \left(\frac{\pi T}{\beta} \left[|f| - \frac{1-\beta}{2T} \right] \right) \right], & \frac{1-\beta}{2T} < |f| \leq \frac{1+\beta}{2T} \\ 0, & \text{otherwise} \end{cases}$$

It is characterized by two values; β , the roll-off factor, and T, the reciprocal of the symbol rate.

The transfer function of IIR filter is given by:

$$H(z) = \frac{\sum_{i=0}^P b_i z^{-i}}{1 + \sum_{j=1}^Q a_j z^{-j}}$$

Where b_i are the feed forward filter coefficients and a_j are the feedback filter coefficients.

III. CIRCUIT DESIGN AND SIMULATION

The circuit diagram for the FBG based optical network is shown in figure 2. The 8 port continuous wave laser source is used to give the input. The transmission frequency of CW laser array starts from 193.1 THz with channel spacing of 25 GHz for the simulation of WDM optical network. The power of the input optical source is -14dBm. All eight unique subsystems act as WDM transmitters. The internal structure of the WDM transmitter is shown in figure 3. The internal structure of the FBG based Demux is shown in figure 4. Different low pass electrical filters are used at the end of receiver.

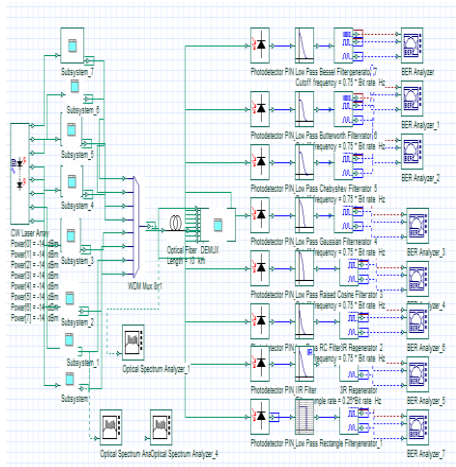

Fig.2 Circuit Diagram of FBG DEMUX WDM System

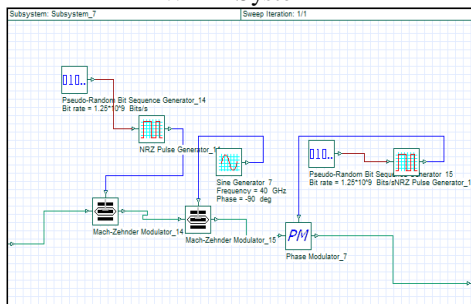

Fig.3 Internal Structure of Transmitter Subsystem

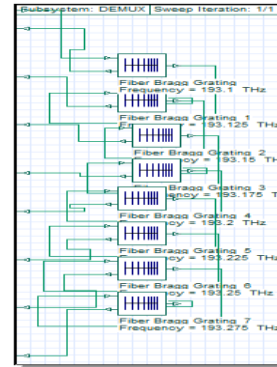

Fig.4 Internal Structure of DEMUX Subsystem

In figure3, the Pseudo Random Bit Sequence Generator (PRBS) is used to generate an arbitrary bit sequence which is given to NRZ pulse generator. This electrical signal is then modulated with the incoming optical signal using a Mach-Zehnder Modulator (MZM). The modulated optical signal is then further modulated using MZM with a carrier sine wave which has a frequency of 40GHz and a 90degree phase lag. This optical signal is then finally modulated using a Phase Modulator having phase deviation of 90 degrees. The output signal from each of these WDM transmitter subsystems is fed to the 8x1WDM Multiplexer which starts with 193.1 THz and channel spacing of 25 GHz. The bandwidth of MUX is set to 10 GHz. Bessel Filter of order 2 is used in the MUX. The multiplexed signal is then launched into a single mode optical fiber of length 10 km, having an attenuation factor of 0.2dB/km and a Differential Group Delay of 0.2ps/km. The optical signal from optical fiber is then passed to a FBG based WDM DEMUX which segregates and filters each wavelength. The Bessel filter in the DEMUX removes noise from the demultiplexed signals.

The optical signals from the DEMUX are detected by PIN Photodiode which converts the optical signals to electrical signals. Each incoming signal is then processed by different electrical low pass filters at different ports to remove any redundant noise and improve the Bit Error Rate (BER) and the Quality Factor (Q-Factor) of the signal.

IV. RESULTS AND DISCUSSIONS

The Q-Factor and the BER at the receiver end vary depending upon the electrical filter used. The input spectrum at 1.25Gbps is shown in the figure 5. The values of Q-factor and BER for quadratic, linear and square root chirp functions at data rates of 1.25 Gbps and 2.5Gbps are given in Table I, Table II and Table III.

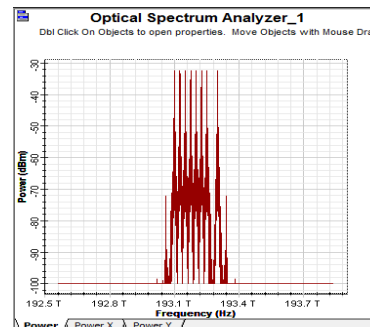

Fig.5 Input Spectrum

TABLE I
QUADRATIC CHIRP

FILTER	BIT RATE			
	1.25 Gbps		2.5Gbps	
	Q-Factor	BER	Q-Factor	BER
Bessel	2.69139	0.00328367	2.59641	0.0046240
Butterworth	2.563	0.00442673	2.40304	0.008093
Chebyshev	2.66762	0.00340426	2.4112	0.007932
Gaussian	2.54712	0.00434988	2.56176	0.005188
Cosine Roll Off	2.55929	0.00411988	2.57562	0.0048850
IIR	2.33973	0.003156	2.53328	0.004347
RC	2.35075	0.00738131	2.54371	0.0054754
Rectangular	2.43224	0.0069456	2.47958	0.005427

TABLE II
LINEAR CHIRP

FILTER	BIT RATE			
	1.25 Gbps		2.5 Gbps	
	Q-Factor	BER	Q-Factor	BER
Bessel	2.8292	0.00217557	2.72944	0.00325
Butterworth	2.6221	0.00373635	2.44493	0.007227
Chebyshev	2.71866	0.00292121	2.45015	0.0071237
Gaussian	2.60355	0.00370126	2.60122	0.0046264
Cosine Roll Off	2.60833	0.00357336	2.62772	0.004195
IIR	2.4058	0.003278	2.38690	0.004532
RC	2.41594	0.00620934	2.58179	0.004905
Rectangular	2.5158	0.0026986	2.43782	0.003987

TABLE III
SQUARE ROOT CHIRP

FILTER	BIT RATE			
	1.25 Gbps		2.5Gbps	
	Q-Factor	BER	Q-Factor	BER
Bessel	2.84625	0.00206006	2.7519	0.0029180
Butterworth	2.64723	0.00347683	2.45927	0.006943
Chebyshev	2.73678	0.00276359	2.46496	0.006840
Gaussian	2.62862	0.00344393	2.61269	0.004472
Cosine Roll Off	2.6268	0.00338465	2.65002	0.0039274
IIR	2.75138	0.00220586	2.586483	0.004235
RC	2.44787	0.00570463	2.59266	0.0047514
Rectangular	2.65384	0.0037431	2.73642	0.0039267

It was observed that at the bit rate of 1.25Gbps, Bessel and Chebyshev filters have highest Q-factor for all the chirp functions. All other electrical filters like Gaussian, Butterworth, and RC are tolerable but possess high BER value. At the bit rate of 2.5Gbps, the electrical filters like Bessel, Gaussian and Cosine Roll-off are having highest value of Q-factor. For linear Chirp function, the Q-factor is found to decrease with the increase in bit rate for most of the filters. The value of BER increases with the increase in bit rate except Rectangular filter. For Quadratic Chirp, the Q-factor increases with increase in bit rate except for Bessel, Butterworth and Chebyshev filters. The value of BER increases with the increase in bit rate except for Rectangular and RC filter. For Square root chirp function, the Q-factor decreases with increase in bit rate except for Cosine Roll off, RC and Rectangular filters. Q-factor gradually increases from Quadratic to linear and then from linear to Square- root Chirp function.

V. CONCLUSION

The performance analysis of various low pass electrical filters like Bessel, Butterworth, Chebyshev, RC, Cosine Roll Off, Gaussian, IIR and Rectangular at different bit rates of 1.25Gbps and 2.5Gbps was done. The Q-factors and BER values of all the filters were tabularized and compared. The performance of Bessel, Butterworth and Chebyshev filters were best among all of the other filters. It was observed that the Bessel filter had the best Q-factor and lowest BER among all the filters for all bit rates. Hence, Bessel filter is the best electrical filter for WDM systems at these bit rates. It was also found that the Quality factor improves with change in Chirp Functions. The best Q factor was attained with square root Chirp Function.

REFERENCES

- [1] C. R. Giles" Lightwave Applications of Fiber Bragg Gratings" JOURNAL OF LIGHTWAVE TECHNOLOGY, VOL. 15, NO. 8, AUGUST 1997.
- [2] J.D. Dwnic, A.B. Ruffin, and J. Hurley, "Ultra low loss optical fiber enabling purely passive 10 Gbits PON system with 100 km length," Opt Express 17, 2009, pp.2392-2399.
- [3] G. F. R. Chen,1 T. Wang,1 C. Donnelly,2 and D. T. H. Tan1," Second and third order dispersion generation using nonlinearly chirped silicon waveguide gratings" Received 24 Sep 2013; revised 4 Nov 2013; accepted 5 Nov 2013; published 18 Nov 2013.
- [4] T. Erdogan, "Fiber Grating Spectra", J. Lightwave Technol.15(8), p. 1277-1294, 1997
- [5] Fouad El-Diasty, Alan Heaney, and Turan Erdogan "Analysis of Fiber Bragg Gratings by a Side-Diffraction Interference Technique" Vol. 40, Issue 6, pp. 890-896 (2001)
- [6] Pavel Ivanoff Reyes, Natalia Litchinitser, Mikhail Sumetsky, and Paul S. Westbrook"160-Gb/s Tunable Dispersion Slope Compensator Using a Chirped Fiber Bragg Grating and a Quadratic Heater",1041-1135, 2005 IEEE
- [7] <http://www.google.com/patents/US20130193961>
- [8] T.deliyannis,yichuang Sun, J.K.fidler "Continuous-Time Active Filter design"chapter 8