

Miniaturization of Microstrip Patch Antenna using Special Shaped DGS, Stub & Slots

Juin Acharjee¹, Vishakha², Mrinmoy Chakraborty³

Assistant Professor, ECE, NSHM Knowledge Campus-Durgapur, West Bengal, India¹

B-Tech, ECE, NSHM Knowledge Campus-Durgapur, West Bengal, India²

Assistant Professor, ECE, Dr. B.C. Roy Engineering College-Durgapur, West Bengal, India³

Abstract: This paper presents the design of circular Microstrip patch antenna (CMPA) and rectangular Microstrip patch antenna (RMPA) with DGS, stub and slots and experimentally studied. Both patch are designed on a Roger RT/duroid 5880(tm) with relative permittivity 2.2. In the absence of DGS, stub and slots, both structure found to resonant at 5.2 GHz. After introducing all these, the CMPA found to resonant at 2.4GHz with bandwidth 60MHz (2.37-2.44 GHz) and RMPA found at 2.5GHz with bandwidth 13MHz (2.44-2.57 GHz). Simulated results show the favourable characteristics in the resonating frequency. The main attractive features for both antennas are miniaturization of near about 117% with simple structure. Both modelled antennas find its applications in wireless communication.

Keywords: DGS, Miniaturization, Return loss, Radiation pattern, Stub, CMPA, RMPA

I. INTRODUCTION

Microstrip patch antennas have been widely used in wireless communication due to its attractive features like light weight, low cost, easy of fabrications, small size. In recent years, small size antenna design at low frequency is very challenging task for researcher. To meet the specifications of microstrip antenna at low frequency with small size, different techniques have been adopted, such as slots on the patch [1], DGS at the ground [2], combination of both [3], substrate of high permittivity [4]. Design of low frequency antenna with large bandwidth is another challenging task for research. To enlarge the bandwidth different techniques have been applied such as connecting stub with the radiating patch [5], mounting patch on two different substrate [6] etc. Different DGS structure [7] has been reported by the researcher to shift down the resonating frequency. In this paper a special Back to Back modified F-shaped of DGS has been introduced to do the same.

In this article two antennas has been designed. Antenna-1 is CMPA (circular micro strip antenna) and Antenna-2 is RMPA (Rectangular Micro strip patch antenna). In the first step, both antennas was designed for resonating frequency 5.2 GHz ,after introducing special shaped DGS, stub and slots in different steps the frequency shifts from 5.2 GHz to 3.2GHz then 3.2GHz to 2.7 and then lastly 2.7GHz to 2.4 GHz for CMPA and for RMPA 5.2GHz to 3.1GHz, then 2.6GHz and lastly 2.6GHz to 2.5GHz. Both proposed antennas have been designed and analysed using matrix of moment (MOM) based electromagnetic solver Ansoft Designerv2.

II. ANTENNA DESIGN

In this paper two micro strip patch antenna has been proposed. One is CMPA and second one RMPA. The geometry of proposed antennas are shown in Figure-2 and

Figure-1.Both antennas are mounted on Rogers RT/duroid 5880(tm) dielectric substrate with relative permittivity 2.2 and loss tangent 0.0009. The radius of the CMPA is 11.2mm and the length and width of RMPA are 22mm, 18mm respectively. The geometry of two antennas is formed by five stages of modifications. In the first stage, a CMPA with radius 11.2mm has been designed for reference antenna (Antenna-1) is shown in Figure-1(a). The excitation is made through co-axial or probe feed technique of an SMA connector. The main advantage of this technique is that, the feed can placed at any place within the patch to match its input impedance which is usually 50 ohm. In the second stage defected ground structure (DGS) is implemented to shift the reference antenna resonating frequency. This DGS creates a discontinuity in signal return path and produces slow wave effect. Due to this the gain of the antenna is reduced and resonant frequency is shifted to lower values 3.2 GHz. The equivalent circuit for DGS is a parallel tuned circuit which is connected in series with the transmission line in which it is coupled [7], shown in Figure-3. Depending on the dimension of DGS structure the equivalent values of R, L, C are determined. In the paper DGS consist of the four main rectangular areas with Back to Back F- shaped structure (Antenna-2).In third stage of the modification an inverted L-shaped stub of nearly quarter wave in length at reference patch resonance is inserted into the optimized position with the patch (Antenna-3). In the fourth stage one rectangular slot is introduced to shift the resonating frequency of Antenna-3 into 2.4 GHz (Antenna-4). This Antenna-4 doesn't satisfy the criteria of IEEE 802.11b specification. To satisfy the criteria of said band in the last stage of modification one more rectangular slot is introduced. So in this proposed antenna can be used for Wireless application. Applying similar stages of

modification two antennas with CMPA and RMPA respectively has been proposed. The stepwise modifications of two proposed antennas are shown in Figure-1(b) and Figure-2(b) respectively. This model also validated by Zeland IE3D software.

Table: 1: Simulated results of Proposed CMPA

Antenna	Resonating Frequency(GHz)	Return Loss(dB)	Gain(dB)
CMPA	5.2	-22	7.031
Antenna-2	3.2	-23.8	4.095
Antenna-3	2.7	-14.7	4.332
Antenna-4	2.7	-21.3	4.548
Proposed Antenna	2.4	-21.9	4.074

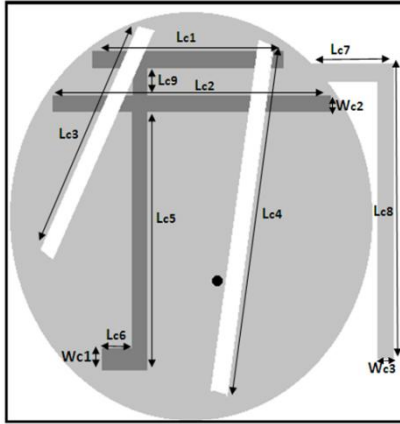

Figure-1: Proposed Circular Microstrip patch Antenna (CMPA)

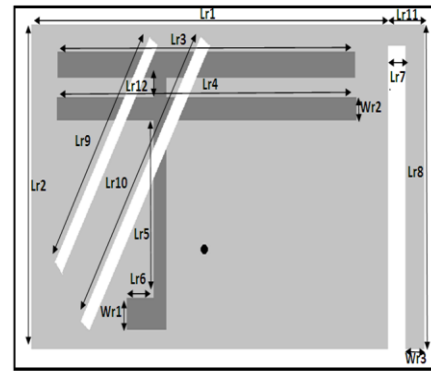

Figure-2 Proposed Rectangular Microstrip patch Antenna (RMPA)

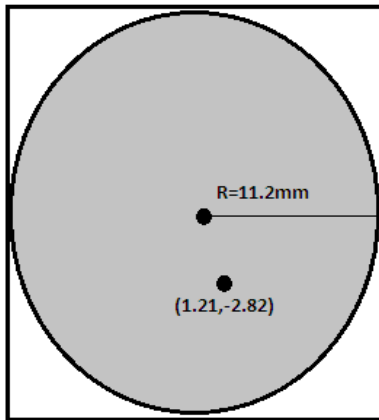

Figure-1(a) CMPA (Reference)

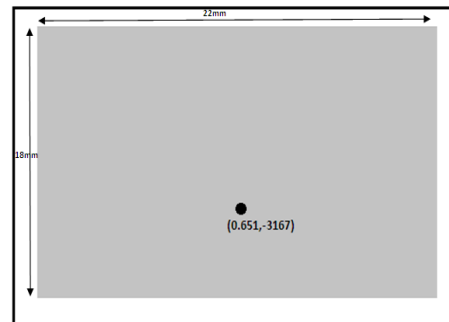

Figure-2(a) RMPA Reference

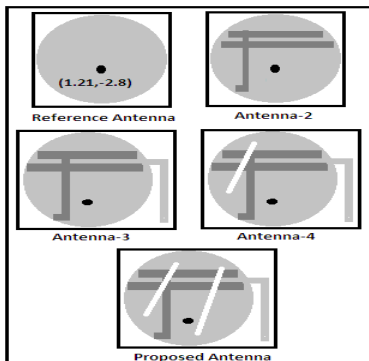

Figure-1(b) Step by step Development of CMPA

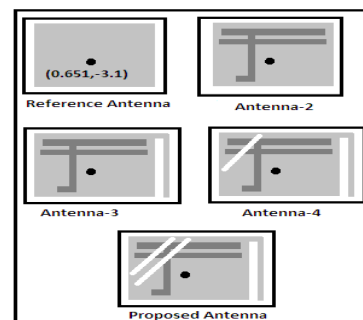

Figure-2(b) Stepwise Development of RMPA

Table-2: Simulated results of Proposed RMPA

Antenna	Resonating Frequency(GHz)	Return Loss(dB)	Gain(dB)
RMPA	5.2	-18.14	7.119
Antenna-2	3.1	-20.8	6.656
Antenna-3	2.6	-10.9	4.332
Antenna-4	2.5	-22.8	4.701
Proposed Antenna	2.5	-24.9	4.783

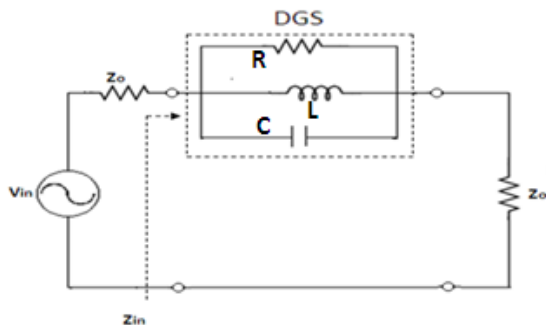

Figure-3 Equivalent Circuit Diagram of DGS

Different Parameter dimension of the CMPA and RMPA are shown in Table-1 and Table-2.

TABLE III: Dimension of different parameters of proposed CMPA:

Parameters	Values	Parameters	Values
Lr1	22mm	Lr8	1mm
Lr2	18mm	Lr9	10.9mm
Lr3	16.5mm	Lr10	20.7mm
Lr4	8.3mm	Lr11	2mm
Lr5	5mm	Lr12	8.3mm
Lr6	3mm	Wr1	1mm
Lr7	1mm	Wr2	0.5mm

Parameters	Values(mm)	Parameters	Values(mm)
Lc1	18	Lc8	13
Lc2	21	Lc9	3.5
Lc3	12.1	Wc1	2
Lc4	19.5	Wc2	1
Lc5	9.5	Wc3	1
Lc6	2	Radius	11.2
Lc7	4		

TABLE IV: Dimension of different parameters of proposed RMPA:

III PERFORMANCE EVALUATION

Observing the simulated response at the resonance frequency of the modelled antenna, it has been observed that the factors which mainly affect the response of model antenna are stub length (L_{c8} , L_{r8}), and gap between two slot. So these dominant factors variations are discussed below.

III (a) Variation of stub length

Figure-5 shows the return loss curve of proposed CMPA with varies values of its length. From these simulation results, it is obvious that this stub has strong effect on resonating frequency. The length of stub is changed from 11.5mm to 14.5mm and for 13.5mm length of stub more impedance matching is done and due to this we optimised the stub length value of proposed antenna to 13.5mm.

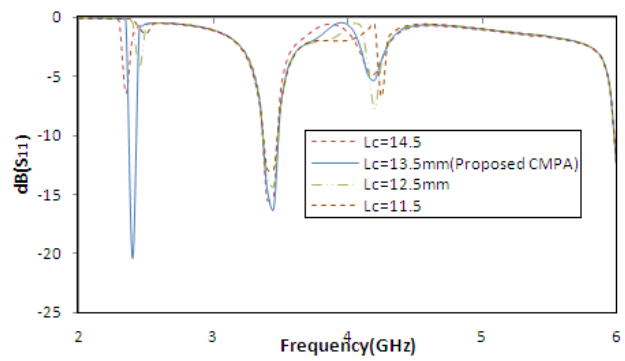

Figure-5 Comparison of the reflection coefficient for different values of L_{c8} when other parameters $L_{c1}=18\text{mm}$, $L_{c2}=21\text{mm}$, $L_{c3}=12.1\text{mm}$, $L_{c4}=19.5\text{mm}$, $L_{c5}=9.5\text{mm}$, $L_{c6}=2\text{mm}$, $L_{c7}=4\text{mm}$, $L_{c8}=13\text{mm}$, $W_{c1}=2\text{mm}$, $W_{c2}=2\text{mm}$, $W_{c3}=2\text{mm}$.

Figure-6 shows the return loss curve of proposed RMPA with varies values of its length. From the said figure it is found this stub played an important role for resonating frequency.

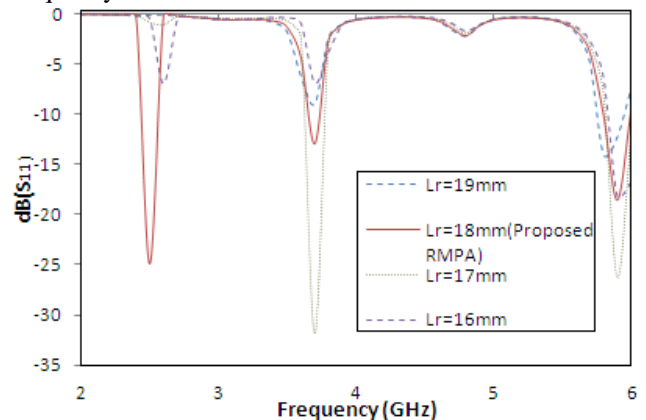

Figure-6 Effect of reflection coefficient for various values of L_{r8} and with $L_{r1}=22\text{mm}$, $L_{r2}=18\text{mm}$, $L_{r3}=16.5\text{mm}$, $L_{r4}=16.5\text{mm}$, $L_{r5}=5\text{mm}$, $L_{r6}=3\text{mm}$, $L_{r7}=2\text{mm}$, $L_{r8}=18\text{mm}$, $L_{r9}=10.9\text{mm}$, $L_{r10}=8.3\text{mm}$, $W_{r1}=1\text{mm}$, $W_{r2}=2\text{mm}$, $W_{r3}=1\text{mm}$.

III (b) Variation of slot distance

Figure -7 shows the effect of slot distance variations on return loss curve of proposed CMPA. The simulated return loss is minimum at resonant frequency 2.4 GHz for the distance $d_c=8.3\text{mm}$. So this distance has been selected as optimized distance.

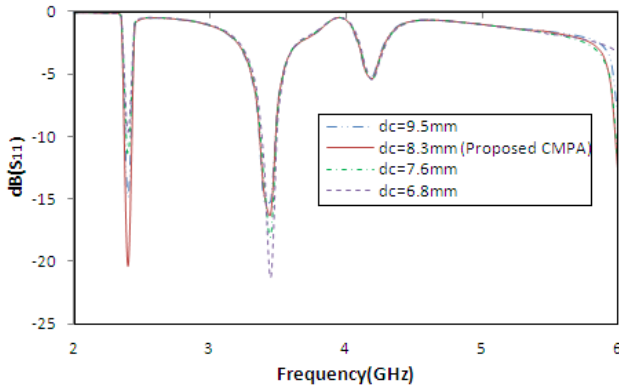

Figure-7 Effect of reflection coefficient for different values of d_r .

Similarly Figure-8 shows the effect of slot distance variation on return loss curve of proposed RMPA. When distance is changed from 3mm to 5mm then for distance $d_r=4.3\text{mm}$ return loss is minimum for the resonating frequency band 2.5GHz.

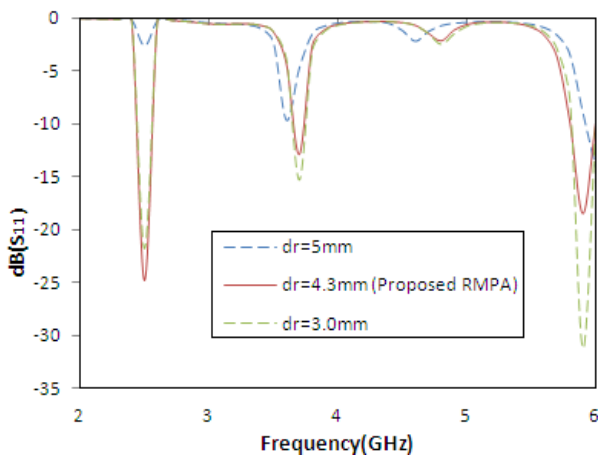

Figure-6 Comparison of reflection coefficient for different values of d_c .

IV RESULT AND DISCUSSION

The simulated return loss versus frequency curve for both proposed antennas are shown in Figure-3 and Figure-4. It is observed that the CMPA yields a good impedance matching from 2.37GHz to 2.44GHz, covering the WLAN frequency band and for RMPA good impedance matching is shown in between 2.44 GHz to 2.56 GHz. So bandwidths of two proposed antennas are 70 MHz and 120 MHz respectively. Minimum -21.53dB and -24.96dB

return loss for two proposed antennas are obtained which is significant.

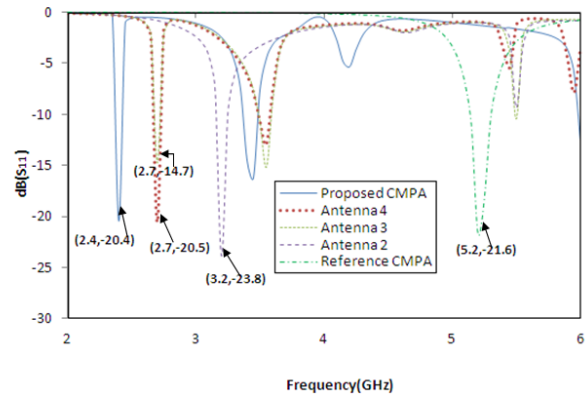

Figure-7 Reflection coefficient characteristics of the antenna shown in Figure-1(b)

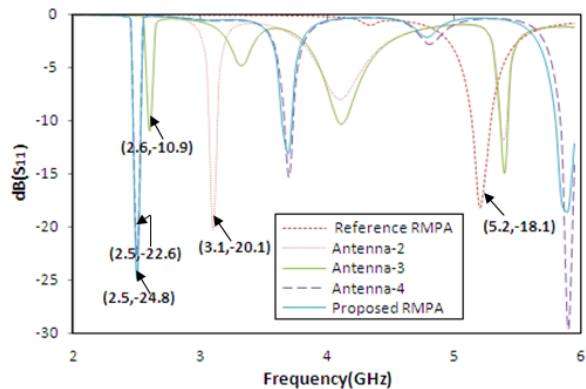

Figure-8 Reflection coefficient characteristics of the antenna shown in Figure-2(b)

The radiation pattern for $\phi=0$ and $\phi=90$ degree means elevation pattern are important for measurement. Figure-9 shows the E-plane and H-plane radiation pattern of proposed CMPA at 2.4GHz. The maximum gain of this circular modelled antenna is 4.07 dB. The 3D input gain of this antenna is shown in Figure -10. Similarly E-plane and H-plane radiation pattern of proposed RMPA at 2.5GHz is shown in Figure-11. The maximum gain of this RMPA is 4.71dB, which is sufficient for resonance band application. The 3d input gain of this antenna is shown in Figure-12.

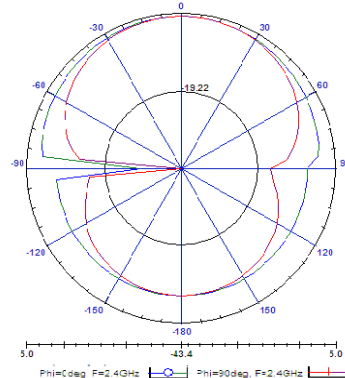

Figure-9 Radiation pattern of proposed CMPA at 2.4GHz

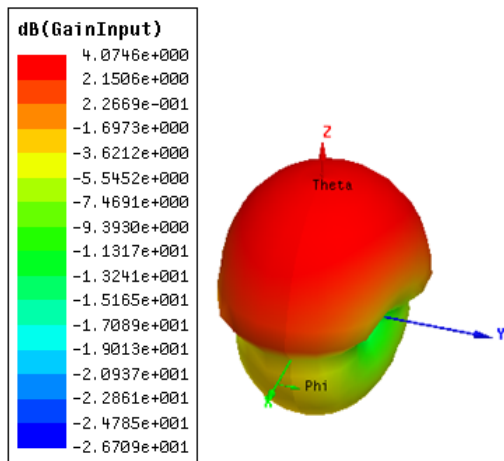

Figure-10 3D input gain of proposed CMPA

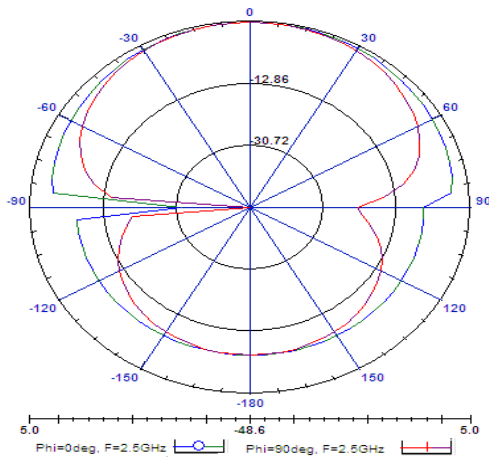

Figure-11 Radiation pattern of proposed RMPA antenna at 2.5GHz

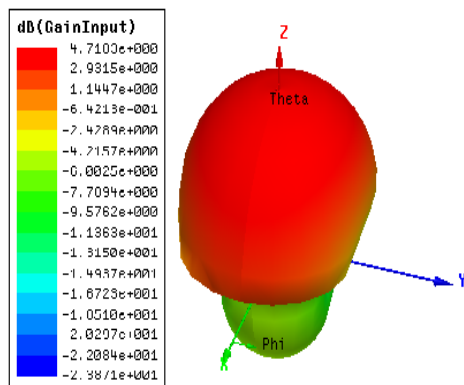

Figure-12 3D input gain of proposed RMPA

Both proposed antennas are also modelled by using Zealand IE3D and both software simulated results are compared in Figure-13 & 14 respectively.

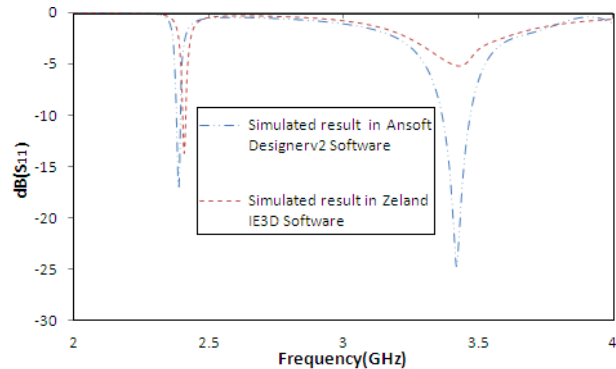

Figure-13 Simulated return loss of proposed circular antenna in two different software.

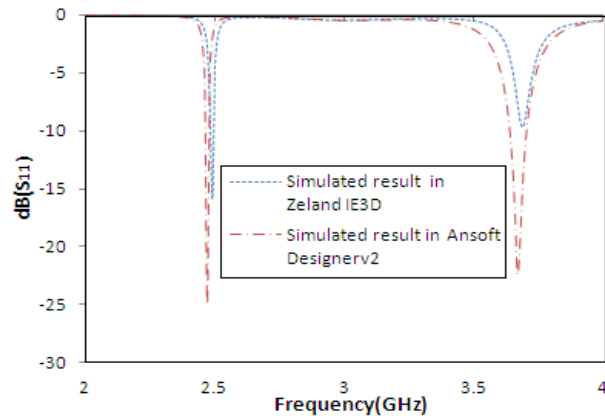

Figure-14 Simulated return loss of proposed rectangular antenna in two different software.

IV CONCLUSION

A compact CMPA and RMPA with DGS, stub and slots has been designed and simulated successfully in this work. A special F-shaped DGS in the ground plane, attaching a inverted L-shaped stub with the patch, and lastly introducing two slots within the patch drastically shift the resonance frequency to 2.4 GHz for CMPA and 2.5GHz for RMPA to give a size reduction of near about 117% which is very much encouraging. Simulated VSWR has been measured at resonance frequency for both bands that are 1.6dB (Circular) & 0.98dB (rectangular) respectively. The maximum simulated gain are 4.01dB (Circular) & 4.71dB (rectangular) which are sufficient for wireless application.

REFERENCES

- [1] U. Chakraborty, A. Kundu, S. K. Chowdhury, A. K. Bhattacharjee, "Compact Dual-Band Microstrip Antenna for IEEE 802.11a WLAN Application", IEEE antennas and wireless propagation letters, vol. 13, 2014.
- [2] Sukhdeep Kaur, Neha Ahuja, "Design of Microstrip Patch Antenna using Defected Ground Structure for WLAN Band", International

- Journal of Computer Applications (0975 – 8887)Volume 67–
No.15, April 2013.
- [3] Mrinmoy Chakraborty, Biswarup Rana, P.P. Sarkar, Achintya Das, "Design and Analysis of a Compact Rectangular Microstrip Antenna with slots using Defective Ground Structure", 2nd International Conference on Computer, Communication, Control and Information Technology, science direct Procedia Technology 00 (2011).
 - [4] T.K. Lo and Y.Hwang, Microstrip antennas of very high permittivity for personal communications, 1997 Asia Pacific Microwave Conference, pp. 253-256.
 - [5] Kun Song, Ying-Zeng Yin, Xiao-Bo Wu, and Li Zhang, "Bandwidth enhancement of open slot antenna with a t-shaped Stub". Microwave and optical Technology letters / vol. 52, no. 2 february 2010
 - [6] Yogesh Bhomia, Ashok Kajla, Dinesh Yadav, "V-slotted Triangular Microstrip Patch Antenna", International Journal of Electronics Engineering, 2(1), 2010, pp. 21-23.
 - [7] A.K Arya, A.Patnaik, and M.V Kartikeyan, "Microstrip Patch Antenna with skew F-shaped DGS for Dual Band operation", progress in Electromagnetic Research ,vol.19,147-160,2011.
 - [8] CA Balanis. "Antenna Theory, Analysis and Design". John Wiley & Sons, New York. 1997.
 - [9] Dabatosh Guha and Yahia M.M. Anter "Microstrip and printed Antenna", new trends, Techniques and applications "2011 John Wiley & Sons Ltd.
 - [10] Ansoft Designerv2: MOM-Based EM Simulator. Web: <http://www.ansoft.com/>.