

# Study of Various Components for Detection of Various Parameters in Electrical Generator

**Yeshudas Muttu**

Student, Electronics & Telecommunication Department, Shree Rayeshwar Institute of Engineering & Information Technology, Shiroda, Goa, India

**Abstract:** The paper focuses on use of various sensors & other components used for detection of various parameters of generator like temperature detection, smoke detection, water level detection & theft detection. The proposed method helps the electrical power generator to work efficiently. The approach uses wireless communication to check to conditions of various backup generators on site. The system works efficiently with use of RF module & action of microcontroller. Thus, the centralised system will connect itself with others present on site.

**Keywords:** LM 35, Wireless module, LCD, Generator, Relay.

## I. INTRODUCTION

Sensors are the ones which sense the environmental conditions & make the computer understand what the situation is about. Speaking in terms of engineering words, Sensors are the transducers that detect the physical condition. Electrical power generators provide electrical energy when there is power cut-off. They work efficiently, but once they are used for longer period of time, its efficiency decreases.

When generators are used for too long, the first part that gets affected is its engine. The parameter that comes to the mind here is temperature. If this temperature exceeds a particular threshold value, the engine may get damaged. The parameter that goes hand-in-hand with this is water level. For engine to be cooled there is a cooling system that is incorporated in the generator. If the water level in this cooling system goes down, the engine & other parts of generator will get affected. Hence water level must be detected.

There may be smoke generated due to short circuit in the engine of the generator. Smoke detection will avoid such damage to the system. Similarly, thieves try to steal the fuel of generator. Hence sensor to avoid such stealing is used. Hence use of sensors just helps the generator to work efficiently. So there is a need to build a centralized system that will continuously (on time-shared basis) communicate with power generator in order to monitor and control the parameters like temperature, smoke level, water level and theft detection that determine the efficiency of the generator.

The proposed system is concerned with the measurement of parameters such as internal temperature, water level in the cooling system, theft detection and smoke detection for determining fuel combustion efficiency of the generator. The System mainly consists of sensors for sensing the above mentioned parameters. The sensor senses the data which is then fed to microcontroller unit. The microcontroller unit transfers the data to the control

system via RF transceiver. The controlling system will analyse and accordingly control the parameters of the power generator.

## II. LITERATURE SURVEY

Waqas Ikram & Nina F.Thornhill has comprehensively described the effectiveness of wireless communication in process automation [1]. According to the research performed, the wireless communication used in industrial application resulted in many advantages such as wear and tear free data transfer, lower installation and maintenance costs, provides powerful mechanisms for controlling parameters. It also provides fairly reliable communication with less expensive connections. BA Akyol, H Kirkham describes about the usage of wireless communication [7] for generator system. According to this research, communication system established using RF wireless network is the best and most effective for monitoring sensors placed at far distances within a certain prescribed range. Considering above research papers, a system can be designed that will use wireless communication to monitor and provide control mechanism to the sensing parameters of the electrical power generator such as internal temperature, pressure, fuel level, smoke detection monitoring. AVR microcontroller [2] is used in this project. This microcontroller is preferred than 8051 and PIC. This is due to following reasons:

- a) AVR microcontroller architecture consists of inbuilt ADC ports which is required for ADC conversion of the sensor outputs, which are Analog in nature.
- b) AVR microcontroller software programming is very much user friendly.

SINAPROG is preferred than BURN-O-MAT for burning the program into the microcontroller chip.

## III. SYSTEM DESIGN COMPONENTS

### 1) ATmega 32 microcontroller:

ATmega32 [8] is an 8-bit high performance microcontroller & is based on enhanced RISC architecture with 131 powerful instructions. Most of the instructions

execute in one machine cycle. Atmega32 can work on a maximum frequency of 16MHz.

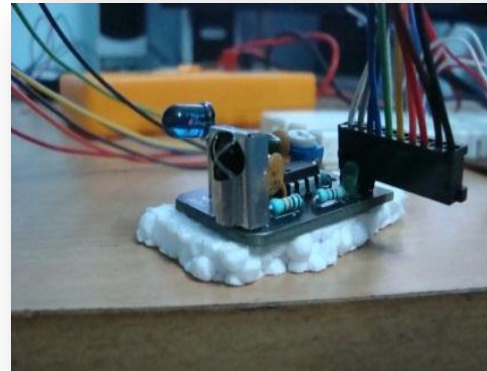
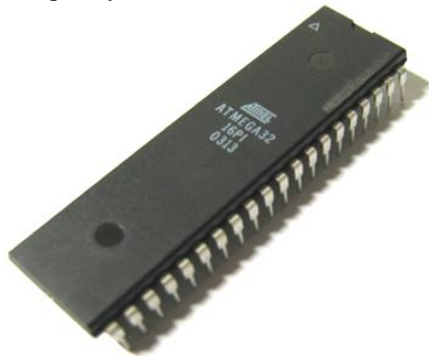

### 2) LM 35 Temperature Sensor

The LM35 [9] is precision integrated-circuit temperature sensor, whose output voltage is linearly proportional to the Celsius temperature. Since it has linear + 10.0 mV/°C scale factor, the temperature value can be calculated very easily and accurately. The output of the sensor is analogous in nature corresponding to a particular temperature reading.

For example, if sensor output is 2.3V then the reading is calibrated as 23°C .

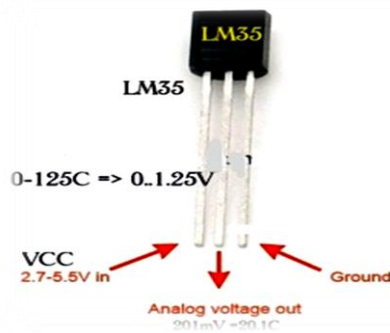

### 3) Proximity sensor

It basically consists of 270-ohm resistor, 10K resistor, Light-emitting diode, Infrared sensitive phototransistor & Prototyping Circuit Board.

The proximity sensor acts as trans-receiver; LED emits Infrared rays which when hits the object, are reflected back. These reflected rays are then received by phototransistor. When target or object is absent, the sensor gives 5V output voltage. When target is present, it gives output of 0V.

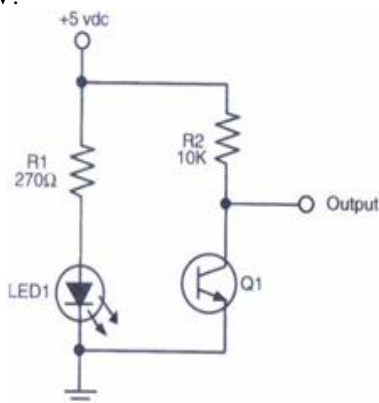

### 4) MQ2 smoke sensor

Two voltages, heater voltage (VH) and test voltage (VC) are required for operation of MQ2 smoke sensor. VH is used to supply suitable working temperature to the sensor, while VC is used to detect voltage (VRL) on load resistance (RL) in series with sensor [6]. Connecting five volts across the heating (H) pins, brings the sensor to a suitable temperature to function properly. Connecting five volts at either the A or B pins causes the sensor to emit an analog voltage on to the other pins. A resistive load between the output pins and ground sets the sensitivity of the detector.

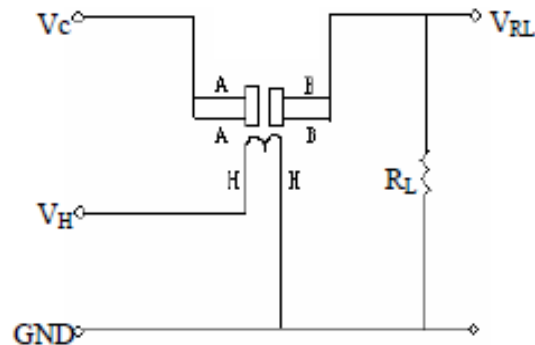

### 5) IC 4066 water level indicator

The circuit uses the widely available CD4066, bilateral switch CMOS IC to indicate the water level through LEDs. When the water is empty the wires in the tank are open circuited and the 180K resistors pulls the switch low. As the water starts filling up, first the wire in the tank connected to S1 and the positive supply are shorted by water. This closes the switch S1 and turns the LED1 ON. As the water continues to fill the tank, the LEDs 2, 3 and 4 light up gradually.

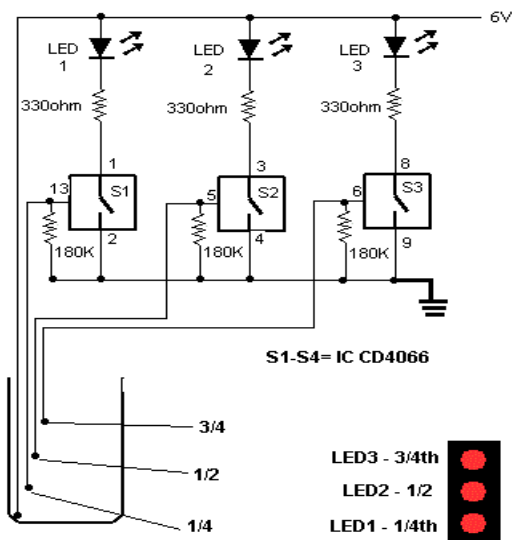

**6) Relay circuit**

Relay is a mechanical switch which enables a user to provide control mechanisms in various applications. It consists of a magnet which causes the tiny rod to be switched from one position to another allowing the flow of current through it. When voltage applied across the pin 1 and ground exceeds 3.4V then rod inside gets switched from position A to position B such that now the circuit connected to position B is active. Power flows from pin 2 to the circuit connected to either position which is active. Hence it is possible to on or off a particular operating system.

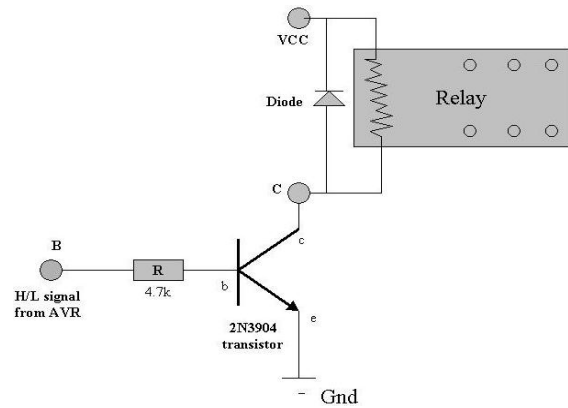

**7) CC 2500 RF module**

This modules basically take TTL data [5] & send it to receiver (receiver whose ID is send along with data). A single module can communicate with number of modules at run time, as receiver ID needs to be sent every time [3]. So, one can send different receiver id every time to communicate with different modules.

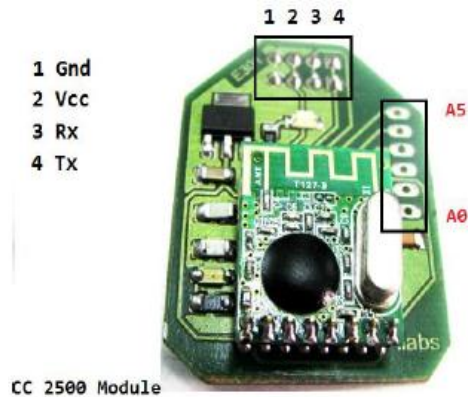

**8) LCD display**

In this project, the LCD display of configuration 16x2 is used as user interface for better handling of the system. The 14-pin LCD [4] used can display 2 lines of 16 characters. The 8 data-line pins of LCD are connected to the PORTC of ATmega32 microcontroller. Pin 4 (RS), Pin 5 (R/W) and Pin 6 (E) known as control pins of LCD are connected to PD5, PD6 and PD7 pins of ATmega32 respectively. The above stated pins of LCD can be connected to any of the free pins except for the interrupt pins of the microcontroller. The 10K Pot (RV1) connected to the Pin 3 (VEE) of LCD is very important. When powered on for the first time, there is need to adjust this pot to get a clear display. Without proper adjustment of this pot, getting a completely blank display is possible.



#### IV. RESULTS

##### 1) LM 35

Correct detection of temperature via LM 35 sensor.



##### 2) Proximity sensor

It detects the presence of hand in front of it.

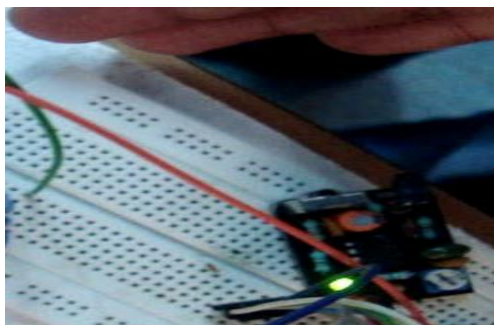

##### 3) Water Level detection

When all three wires are dipped in water it denotes presence of high water level.

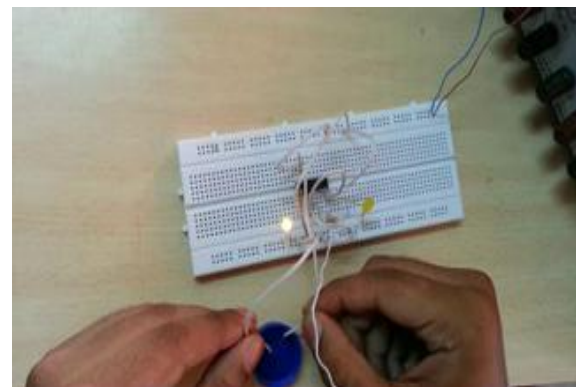

##### 4) CC 2500 module communicating with LED blinking

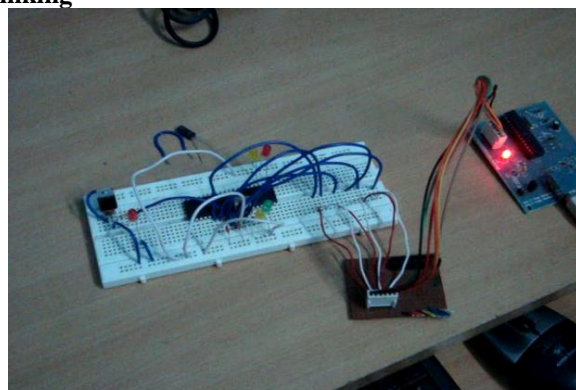

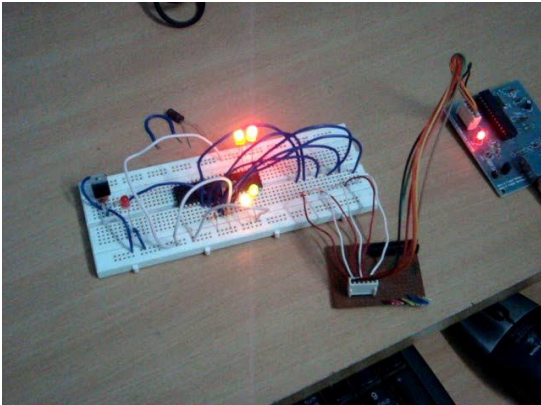

#### IV. CONCLUSION & FUTURE WORK

A centralized system that will continuously (on time-shared basis) communicate with backup power generator in order to monitor and control the parameters that determines the efficiency of the generator was implemented. This project application can be extended to any other device, other than generators. Such as it can be used to determine and control the water level in normal water tanks used in factories or home applications. Detection and control of smoke also can be used in chambers especially in industries and factories. It is possible to make the controlling section of the developed system portable by using android application instead of the LCD display at the receiver. So that the management person can determine the condition updates of the generator portably.

#### REFERENCES

- [1]. BA Akyol,H Kirkham,SL Clements and MD Hadley, "Communication for generator system", presented at U.S.department of energy, Pacific North west National Lab, Richland Washington, January 2010.
- [2]. AVR Tutorials- involves study of basic AVR microcontroller.
- [3]. Using USART of AVR Microcontrollers. eXtreme Electronicse Xtreme Electronics.htm
- [4]. [www.extremeelectronics.com/avr-tutorials/using-lcd-module-involves-the-functioning-and-programming-of-lcd-display](http://www.extremeelectronics.com/avr-tutorials/using-lcd-module-involves-the-functioning-and-programming-of-lcd-display).
- [5]. CC2500 Tutorials- involves the study of basic RF module communication.
- [6]. <http://www.pololu.com/file/0J309/MQ2.pdf>
- [7]. Waqas Ikram & Nina F. Thornhill, "Wireless Communication in Process Automation: A Survey of Opportunities, Requirements, Concerns and Challenges", Centre for Process Systems Engineering, Imperial College London.
- [8]. Using the Analog To Digital Converter.eXtreme Electronics.htm
- [9]. [www.engineersgarage.com/electronic-components/lm35-sensor-datasheet](http://www.engineersgarage.com/electronic-components/lm35-sensor-datasheet)
- [10]. [www.avrfreaks.net](http://www.avrfreaks.net) for AVR programming.