

Three way controlled android Smartphone based robotic vehicle via Bluetooth

Arita Dey¹, Akash Pal², Sayantan Nandi³, Lusika Roy⁴

B.Tech Student, Department of EE, JIS College of Engineering, Kalyani, India¹

B.Tech, Department of CSE, JIS College of Engineering, Kalyani, India²

B.Tech Student, Department of CE, JIS College of Engineering, Kalyani, India³

Assistant Professor, Department of EE, JIS College of Engineering, Kalyani, India⁴

Abstract: Robots are smart machines that can be programmed and used in many areas such as industry, manufacturing, production lines, or health, etc. Today human-machine interaction is moving away from mouse and pen and is becoming pervasive and much more compatible with the physical world. With each new day the gap between machines and humans is being bridged with the introduction of new technologies to ease the standard of living. As the Smartphone era has evolved with innovative android based applications, engineers are improvising them to improve robotic vehicles which diminish the aforesaid abyss. In this paper we have developed a three way control for the robotic vehicle in which we have used Bluetooth communication to interface the microcontroller and the inbuilt sensors in the android Smartphone. According to commands received from android phone, the kinematics of the robot is controlled. The developed robotic vehicle can be used for numerous applications in the future especially in the field of surveillance and security.

Keywords: Robotic Vehicle, Android Smartphone, Bluetooth, Three ways controlled.

I. INTRODUCTION

Smartphone's, a compact rather powerful device is rapidly breaking the traditional barriers that come in the way of human-machine interaction. Smartphone's in the recent times have become more affordable and efficient devices which can be used to support collaborative activities in a community. It is a result of a huge advancement in mobile phones technology. Humans are anxiously working on finding new ways of interacting with machines. Modern Smartphone comes equipped with different sensors such as proximity sensor, accelerometer sensor, ambient light sensor and many more. They also have features like Bluetooth and extremely powerful operating systems such as Symbian, Bada, and Android OS and so on. Thank for Bluetooth technology and other similar techniques, with dramatic increase in Smartphone users, smart phones have gradually turned into an all-purpose portable device and provided people for their daily use [1][2]. Among all available mobile operating systems Android OS has gained significant and immense popularity after being launched in 2008, dethroning all competitors due to its open architecture. Android platform has revolutionized the field of application development for smart phone, opening new dimensions for technical exploration and innovation [3][4]. The developed robotic vehicle explained in the paper has a very simple work process. The readings of the sensors in the Smartphone are collected as data which is transmitted to the robotic vehicle via Bluetooth module of Smartphone using the three developed android apps. Further, it is processed by a microcontroller embedded on the robotic vehicle for its desirable kinematics. In this context, a robot is anonymous to any machine that is controlled by humans varying from simple toys to heavy

machineries [5]. Robots have even replaced humans in performing various tasks that they are unable to perform due to physical disability, size limitation or extreme environments. For past two decades, researchers from around the world have shown keen interest in gesture and voice technology and its possibilities in various fields making it a powerful tool for humans. Smartphone's have proved to be of much more aid than being just a device to make calls. The large world is merging together into the palms of humans in the form of a Smartphone.

II. CONSTRUCTIONAL DETAILS

In this part of the paper we are going to discuss about the important parts of the robotic vehicle. The illustrations are provided below.

A. Arduino Uno R3

The Arduino Uno is a microcontroller board based on the ATmega328. It has 14 digital input/output pins (of which 6 can be used as PWM outputs), 6 analog inputs, a 16 MHz ceramic resonator, a USB connection, a power jack, an ICSP header, and a reset button. It contains everything needed to support the microcontroller. It can be simply connected to a computer with a USB cable. It can be powered with a AC-to-DC adapter or battery to get started. The Uno differs from all preceding boards in that it does not use the FTDI USB-to-serial driver chip. Instead, it features the Atmega16U2 (Atmega8U2 up to version R2) programmed as a USB-to-serial converter. The Arduino integrated development environment (IDE) is a cross-platform application written in Java. It includes a code editor with features such as syntax highlighting, brace

matching, and automatic indentation, and is also capable of compiling and uploading programs to the board with a single click. A program or code written for Arduino is called a "sketch".

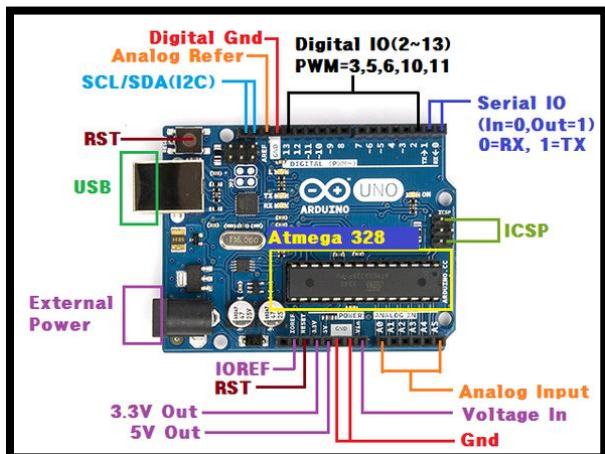

Figure 1: Arduino Uno R3

B. HC-05 Serial Bluetooth Module:

Bluetooth is a wireless communications protocol running at 2.4 GHz, with client-server architecture, suitable for forming personal area networks. Bluetooth is an extremely integral feature designed for low power devices [6][7]. Bluetooth is a standardized feature or specification that is available in all Smartphone running on android, laptops and computers. It is very handy as it can be easily fitted with a module to allow Bluetooth communication. Bluetooth is the only appropriate communications protocol that has no fear of getting the frequency interferences because it uses the MAC Address of the device i.e. Bluetooth allows the connectivity between two devices using their MAC Address.

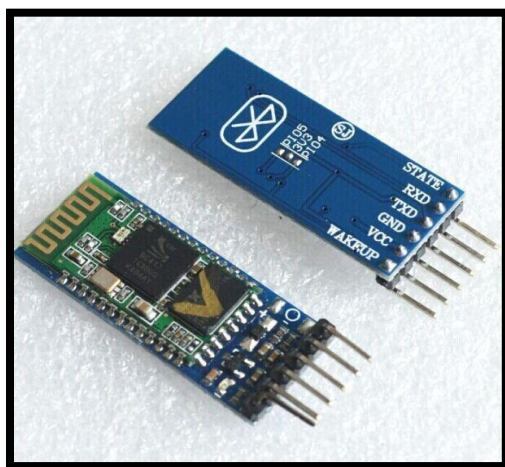

Figure 2: HC-05 Module

HC-05 module shown in Figure-1 is an easy to use Bluetooth SPP (Serial Port Protocol) module, designed for transparent wireless serial connection setup. Serial port Bluetooth module is fully qualified Bluetooth V2.0+EDR (Enhanced Data Rate) 3Mbps Modulation with complete 2.4GHz radio transceiver and baseband. It uses CSR

Bluecore 04-External single chip Bluetooth system with CMOS technology and with AFH (Adaptive Frequency Hopping Feature). HC-05 module work on 3.0V low power operation and 3.0 to 4.2V I/O controls. It has integrated antenna, edge connector and UART interface with programmable baud rate. HC-05 module has default Baud rate: 38400, Data bits:8, Stop bit:1,Parity: No parity and supported baud rates are 9600, 19200, 38400, 57600, 115200, 230400, 460800.

C. L293D Motor Driver IC:

The L293D motor driver ICs are quadruple high-current half H drivers. The L293D motor driver IC is designed to provide bidirectional drive currents of up to 600mA at voltages from 4.5V to 36V. The L293D motor driver IC are designed to drive inductive loads such as relays, solenoids, dc and bipolar stepping motors, as well as other high-current/high voltage loads in positive-supply applications.

An external high-speed output clamp diodes should be used for inductive transient suppression while Using L293D motor driver IC. A terminal V_{cc1} separate from V_{cc2} is provided for the logic inputs to minimize device power dissipation. The L293D motor drivers are characterized for operation from 0°C to 70°C.

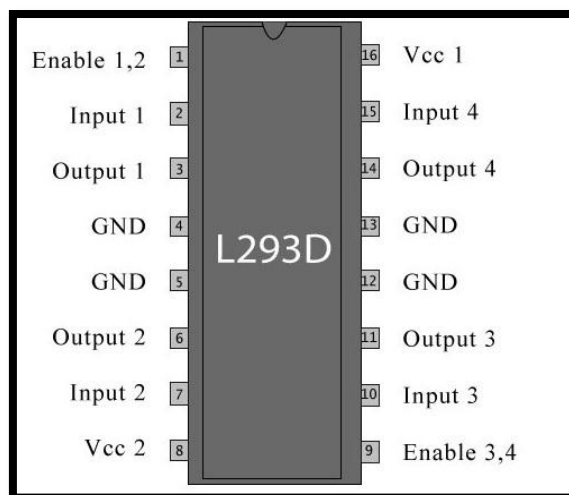

Figure 3: L293D Pin Diagram

[1] Working of L293D

The 4 input pins for this l293d, pin 2, 7 on the left and pin 15, 10 on the right as shown on the pin diagram. Left input pins will regulate the rotation of motor connected across left side and right input for motor on the right hand side. The motors are rotated on the basis of the inputs provided across the input pins as LOGIC 0 or LOGIC 1.

In simple you need to provide Logic 0 or 1 across the input pins for rotating the motor.

[2] L293D Logic Table

Consider a Motor connected on left side output pins (pin 3, 6). For rotating the motor in clockwise direction the input pins has to be provided with Logic 1 and Logic 0.

- Pin 2 = Logic 1 and Pin 7 = Logic 0 | Clockwise Direction

- Pin 2 = Logic 0 and Pin 7 = Logic 1 | Anticlockwise Direction
- Pin 2 = Logic 0 and Pin 7 = Logic 0 | Idle [No rotation] [Hi-Impedance state]
- Pin 2 = Logic 1 and Pin 7 = Logic 1 | Idle [No rotation]

In a very similar way the motor can also operated across input pin 15, 10 for motor on the right hand side.

D. DC Motor:

Almost every mechanical movement that we see around us is accomplished by electrical motors. Motors take electrical energy convert it into useful mechanical energy. Electrical motors are used to power hundreds of devices we use in our daily lives. From small motor applications including hand power tools, food blenders, mixer-grinders, washing machines to large motor applications such as automobiles, heavy lifting in industries and many more.



Figure 4: DC Motor

III. BLOCK DIAGRAM

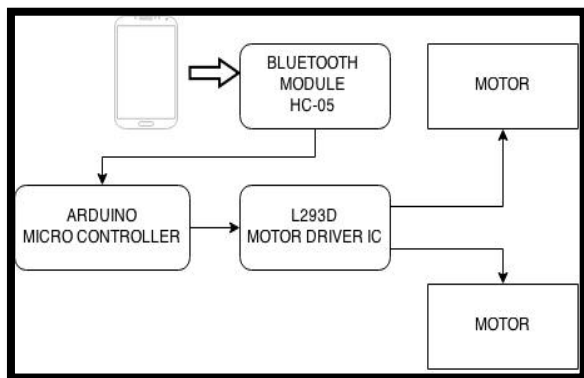

Figure 5: Block Diagram

The android Smartphone is connected with the Arduino microcontroller via the Bluetooth module. Initially the application is not connected to the Arduino. After switching on the Bluetooth on the Android Device, the Bluetooth symbol within the application has to be pressed.

This brings up a list of the available Bluetooth devices. From this list the HC-05 Bluetooth module is selected followed by entering a default password ensuring that only that particular Android device would be able to interact with the Arduino microcontroller.

The instruction from Smartphone goes to Arduino via Bluetooth module. Based on the program loaded into the microcontroller various signals go to the Motor Driver IC. Based on the input signals to the Motor Driver, the DC motors move forward, backward, left, right or stop as per the chosen application.

IV. CIRCUIT DIAGRAM

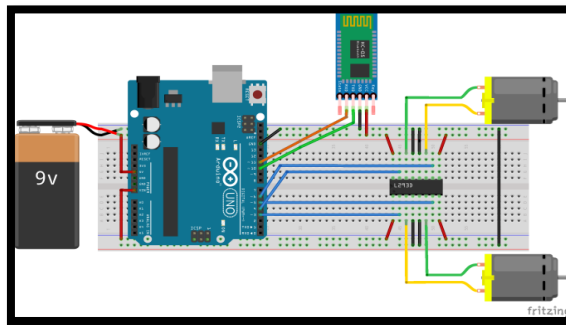

Figure 6: Circuit Diagram showing the connections of the different components.

V. ROBOTIC VEHICLE

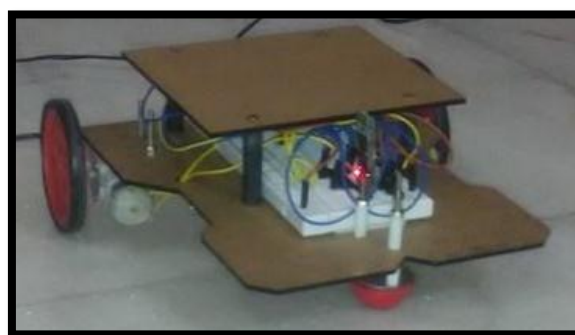

Figure 7: Developed Robotic Vehicle

VI. DEVELOPED APPS

The android applications has been developed using the **MIT APP INVENTOR 2**. [13]

Three Android applications have been developed:

A. Direction Control App

The application is connected to the Arduino the status of the application changes to “Connected”. Now If the up arrow is pressed the vehicle moves forward, if the back arrow is pressed the vehicle moves back and similarly with the other buttons. It is to be noted that to stop the vehicle the red button in the centre has to be pressed or else the vehicle will keep moving in the direction of the last button pressed.



Figure 8: Screenshot of Direction Control App

B. Voice Control App:

The application is connected to the Arduino the status of the application changes to “Connected”. Before giving the voice commands the microphone button has to be pressed. This particular application deals with the conversion of the received voice commands to text and transfers the text to the connected Bluetooth module. The Arduino receives the text from the Bluetooth module as characters and stores them as a string. There are words pre-programmed (forward, reverse, right, left and stop) into the Arduino, whenever the received text matches with the pre-programmed words, the Arduino executes the command that is assigned to the words.

[NOTE: Only one voice command can be processed by the Arduino at a given time. So a single command should be given after pressing the microphone button.]

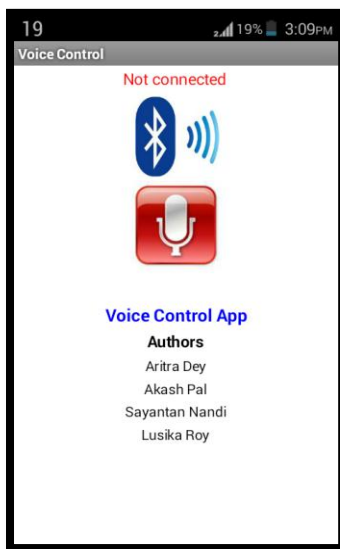

Figure 9: Screenshot of Voice Control App

C. Tilt Control App:

This application makes use of the accelerometer sensor within the android device. The accelerometer sensor can detect shaking and measure acceleration approximately in three dimensions (xAccel, yAccel, zAccel) using SI units (m/s²).

The three components are:

xAccel: 0 when the phone is at rest on a flat surface, positive when the phone is tilted to the right (i.e., its left side is raised), and negative when the phone is tilted to the left (i.e., its right side is raised).

yAccel: 0 when the phone is at rest on a flat surface, positive when its bottom is raised, and negative when its top is raised.

zAccel: Equal to -9.8 (earth's gravity in meters per second per second when the device is at rest parallel to the ground with the display facing up, 0 when perpendicular to the ground, and +9.8 when facing down. The value can also be affected by accelerating it with or against gravity.[13]

When the mobile phone is held parallel to the ground then the vehicle stops. On tilting the mobile phone right the vehicle moves right and same for the left motion. To move

the vehicle forward the device is held perpendicular to the ground facing upwards and for backward movement the device is held perpendicular to the ground facing downwards.

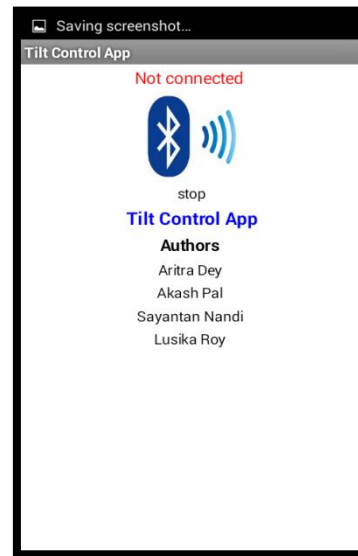

Figure 10: Screenshot of Tilt Control App

VII. APPLICATIONS AND FUTURE SCOPE

The future applications of the developed android based robot are enlisted below:

- Bluetooth based home automation system using Android phones.
- Exploiting Bluetooth on android mobile devices for home security application
- Surveillance Application: An android application can be used to send live feeds from the camera on the android Smartphone to a server, which can then be directed to a PC via the web.
- Fire Fighting Robot with Android Application.
- Remote control of car or vehicle.
- Military applications.
- Construction Robot.
- Load carrying

VIII. CONCLUSION

This paper presents three approaches of controlling a robotic vehicle using an android Smart phone. Android Smart Phones are available at reasonable price in the market. As there is a huge increment in the number of people using android smart phone, the possibility of exploiting various applications using the smart phone also increases.

Every android smart phone has a Bluetooth which provides the ability to connect to other Bluetooth devices wirelessly without an internet connection. The robotic vehicle can be easily controlled by installing the apk files (Android Application Package) of the three applications on the android smart phone. The android application makes use of the sensors within the android device, so no extra charges for different sensors gets included in the project.

Then a connection is established between the application and the arduino via the Bluetooth module. The instructions are passed from the smart phone to the microcontroller. Based on the instructions different signals are sent out to the motor driver, which ultimately drivers the motors attached to the wheel.

This technique could be easily used in other applications. Instead of just one, multiple motor drivers can be used. These motor drivers can be used to control any kind of motor.

REFERENCES

- [1] Piyare, R. and Tazil, M. (2011) "Bluetooth based home automation system using Android phones". IEEE 15TH International symposium on consumer electronics (ISCE), 14-17 june 2011, Singapore.
- [2] Potts, J. and Sukittanon, S. (2012) "Exploting bluetooth on android mobile mobile devices for home security application", proceedings of southeastcan, 15-18 March 2012, orlando, florida, USA
- [3] G'obel, S., Jubeh, R., Raesch, S. L., and Z'undorf A., "Using the Android Platform to control Robots", Kassel University Germany.. Available:
www.innoc.at/fileadmin/user_upload/_temp_/RiE/.../65.pdf.
- [4] Selvam, M. "Smart phone based robotic control for surveillance applications." Dept. of ECE, Karpagam University, Coimbatore, Tamil Nadu, International Journal of Research in Engineering and Technology (2014).
- [5] Saini, Arvind Kumar, Garima Sharma, and Kamal Kishor Choure. "BluBO: Bluetooth Controlled Robot."
- [6] Khurana, Anil. "Bluetooth Based Robotic Car."
- [7] AKSOZ, Ahmet, Salim ENGIN, and Mahir DURSUN. "The Implementation of Controlled Humanoid Robot with Android."
- [8] Javale, Deepali, et al. "Home automation and security system using android adk." International journal of electronics communication and computer technology (IJECCCT) 3.2 (2013).
- [9] Available:
[http://en.wikipedia.org/wiki/Android_\(operating_system\)](http://en.wikipedia.org/wiki/Android_(operating_system)).
- [10] Available: <http://www.webopedia.com/TERM/R/robotics.html>.
- [11] Available:
http://Compnetworking.about.com/cs/bluetooth/g/bldef_bluetooth.html.
- [12] "How Bluetooth Technology Works", www.bluetooth.com/bluetooth/technology/works.
- [13] MIT App Inventor-appinventor.mit.edu/