

Elimination of Harmonics in Power System Using FFT analysis

A. Yuvaraj¹

Assistant Professor, Department of Electrical and Electronics Engineering, Apollo Engineering College,
Chennai, Tamil Nadu, India¹

Abstract: The electronic circuits such as inverters, choppers, cyclo-converters, SMPS used by industrial and domestic purposes are non-linear in nature. Due to the non-linearity effects the problems such as heating, equipment damages, EMI related problems in power system. The harmonic filter is the best solution for eliminating the harmonics caused by the non-linear loads.

Keywords: Total Harmonic Distortion (THD), Adjustable Frequency Controller (AFC), Matrix Laboratory (MATLAB), Fast Fourier Transform (FFT).

I. INTRODUCTION

Power quality determines the fitness of electrical power to consumer devices. Synchronization of the voltage frequency and phase allows electrical systems to function in their intended manner without significant loss of performance or life. The term is used to describe electric power that drives an electrical load and the load's ability to function properly. Without the proper power, an electrical device (or load) may malfunction, fail prematurely or not operate at all.

There are many ways in which electric power can be of poor quality and many more causes of such poor quality power. The electric power industry comprises electricity generation (AC power), electric power transmission and ultimately electricity distribution to an electricity meter located at the premises of the end user of the electric power. The electricity then moves through the wiring system of the end user until it reaches the load. The complexity of the system to move electric energy from the point of production to the point of consumption combined with variations in weather, generation, demand and other factors provide many opportunities for the quality of supply to be compromised.

Power conditioning is modifying the power to improve its quality. An uninterruptible power supply can be used to switch off of mains power if there is a transient (temporary) condition on the line. However, cheaper UPS units create poor-quality power themselves, akin to imposing a higher-frequency and lower-amplitude square wave atop the sine wave. High-quality UPS units utilize a Double conversion topology which breaks down incoming AC power into DC, charges the batteries, then remanufactures an AC sine wave. This remanufactured sine wave is of higher quality than the original AC power feed. A surge protector or simple capacitor can protect against most overvoltage Conditions, while a lightning arrester protects against severe spikes.

II. HARMONICS AND ITS EFFECTS

Harmonics provides a mathematical analysis of distortions to a current or voltage waveform. Based on Fourier series, harmonics can describe any periodic wave as summation of simple sinusoidal waves which are integer multiples of the fundamental frequency. Harmonics are steady-state distortions to current and voltage waves and repeat every cycle. They are different from transient distortions to power systems such as spikes, dips and impulses. One of the major effects of power system harmonics is to increase the current in the system. This is particularly the case for the third harmonic, which causes a sharp increase in the zero sequence current, and therefore increases the current in the neutral conductor. This effect can require special consideration in the design of an electric system to serve non-linear loads. In addition to the increased line current, different pieces of electrical equipment can suffer effects from harmonics on the power system.

II.A. TOTAL HARMONIC DISTORTION

The total harmonic distortion, or THD, of a signal is a measurement of the harmonic distortion present and is defined as the ratio of the sum of the powers of all harmonic components to the power of the fundamental frequency. THD is used to characterize the linearity of audio systems and the power quality of electric power systems. Distortion factor is a closely related term, sometimes used as a synonym.

$$THD = \frac{\sqrt{H_2^2 + H_3^2 + H_4^2 + \dots + H_n^2}}{H_1}$$

III. SIMULATION CIRCUIT DIGRAM

SimuLink (simulation and Link) is an extension of MATLAB by math works Inc. It works with MATLAB to offer modeling, simulating, and analyzing of dynamical systems under a graphical user interface (GUI)

environment. The construction of a model is simplified with click-and-drag mouse operations. SimuLink includes a comprehensive block library of toolboxes for both linear and nonlinear analyses.

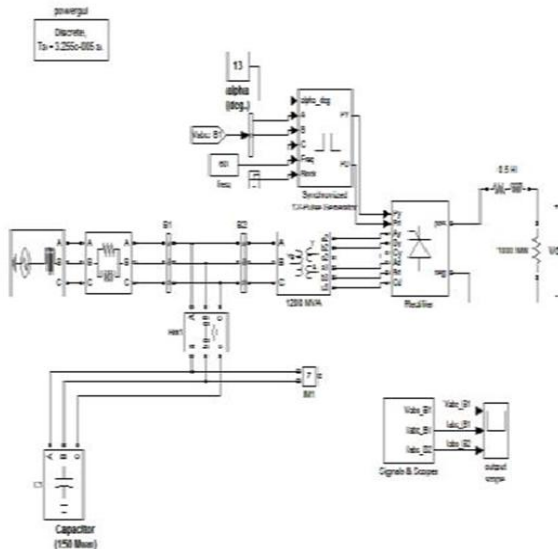

Fig.1. Simulation circuit diagram without Harmonic Filter

III. A. WITH HARMONIC FILTER

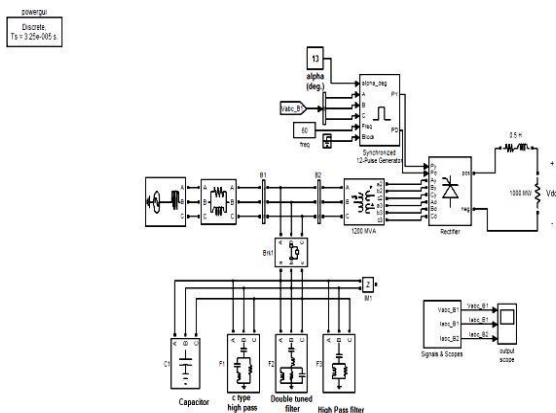

Fig.2. Simulation circuit diagram with Harmonic Filter

IV. CIRCUIT DEMONSTRATION

Three-phase harmonic filters are shunt elements that are used in power systems for decreasing voltage distortion and for power factor correction. Nonlinear elements such as power electronic converters generate harmonic currents or harmonic voltages, which are injected into power system. The resulting distorted currents flowing through system impedance produce harmonic voltage distortion. Harmonic filters reduce distortion by diverting harmonic currents in low impedance paths. Harmonic filters are designed to be capacitive at fundamental frequency, so that they are also used for producing reactive power required by converters and for power factor correction. The Three-Phase Harmonic Filter is built of RLC elements. The resistance, inductance, and capacitance

values are determined from the filter type and from the following parameters:

- Reactive power at nominal voltage
- Tuning frequencies
- Quality factor.

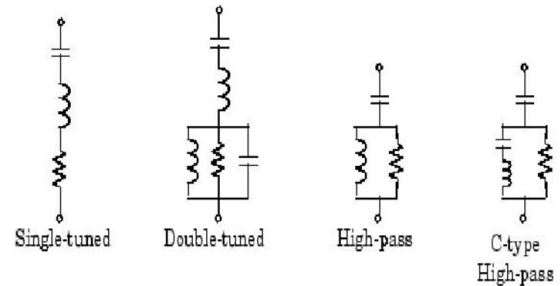

Fig.3. Three-phase Harmonic Filter

The simplest filter type is the single-tuned filter. The above figure gives the definition of the quality factor Q and practical formulae for computing the reactive power QC and losses (active power P). The quality factor Q of the filter is the quality factor of the reactance at the tuning frequency $Q = (n.XL)/R$.

V. FFT ANALYSIS

The FFT analysis will be performed on the portion of the signal starting at the specified time and for the specified number of cycles. Number of cycles: Specify the number of cycles of the selected signal to analyze for the FFT analysis. Fundamental frequency: Specify the fundamental frequency, in hertz (Hz), as a reference frequency for the FFT analysis. Display style: In the pull-down menu, select Bar (relative to fundamental) to display the spectrum as a bar graph relative to the fundamental frequency. Select Bar (relative to specified base) to display the spectrum as a bar graph relative to the base defined by the Base value parameter. Select List (relative to fundamental) to display the spectrum as a list in % relative to the fundamental or DC component. Select List (relative to specified base) to display the spectrum as a list in % relative to the base value defined by the Base value parameter. Base value: Enter a base value for the display of harmonics. Frequency axis: In the pull-down menu, select Hertz to display the spectrum frequency axis in hertz. Select Harmonic order to display the spectrum frequency axis in harmonic order relative to the fundamental frequency.

VI. OUTPUT WAVEFORMS

Before implementing the three phase harmonic filter the waveforms are generated to compare the total harmonic distortion with the implementation of the project. In the output waveforms the three phase voltage and currents such as Vabc, I abc gets distorted due to the effect of harmonics. The total harmonic Distortion also can be calculated using FFT analysis. Its value is nearly 13.5%. The importance of the three phase harmonic filter can be realized by observing the voltage and current harmonics.

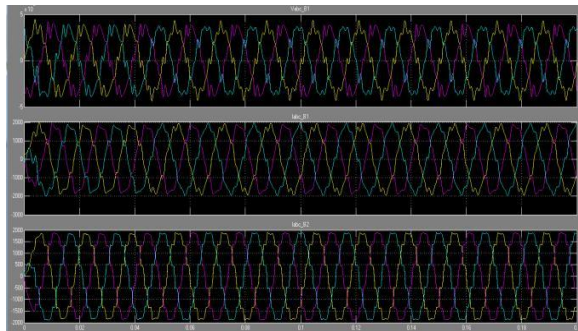

Fig.6.Simulation output without Harmonic Filter

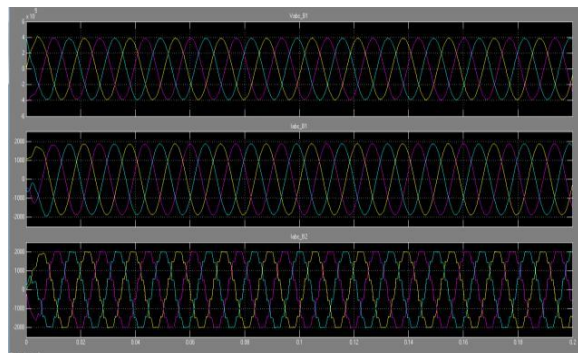

Fig.7.Simulation output with Harmonic Filter

With the help of Harmonic filter, three phase waveforms distortion is reduced and the waveforms are more or less maintained as pure sinusoidal (around 80-85%). The Total harmonic Distortion value is 0.55% obtained with the help of harmonic filter.

VII. WITHOUT HARMONIC FILTER (THD=14.15%)

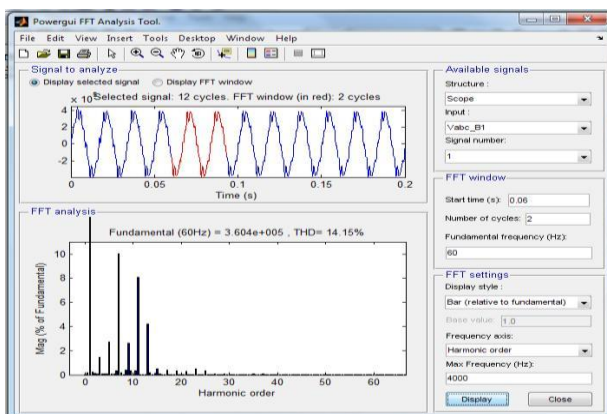

Fig.8.Powergui FFT analysis tool

The percentage of the total harmonic distortion is calculated with help of FFT analysis tool. The THD value is 14.15% as mentioned in the above figure.

VII.A.WITH HARMONIC FILTER (THD=0.55%)

The percentage of the total harmonic distortion is calculated with help of FFT analysis tool. The THD value is 0.55 % as mentioned in the below figure.

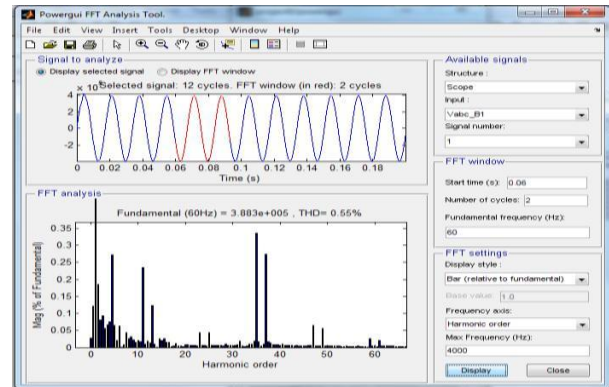

Fig.9. Powerful FFT analysis tool

VIII.CONCLUSION

Three-phase harmonic filters are shunt elements that are used in power systems for decreasing voltage distortion and for power factor correction. Nonlinear elements such as power electronic converters generate harmonic currents or harmonic voltages, which are injected into power system. The resulting distorted currents flowing through system impedance produce harmonic voltage distortion. Harmonic filters reduce distortion by diverting harmonic currents in low impedance paths. Harmonic filters are designed to be capacitive at fundamental frequency, so that they are also used for producing reactive power required by converters and for power factor correction. By connecting the Harmonic filter in the transmission line, the line voltages and currents maintained as sinusoidal. The total harmonic distortion of the waveforms can be calculated with the help of MATLAB software. It can be calculated a 0.55%. So that the effect of the harmonics in the power system can be eliminated considerably. In phase-I the simulation output has been completed.

REFERENCES

- [1] Saswat Kumar Ram, Bane Bandana Das "Comparison of different control strategy of conventional and Digital Controller for Active Power Line Conditioner (APLC) for Harmonic Compensation" IEEE Trans on power Delivery, 978-1-4673-3059-6, 2013.
- [2] M. Martinez "Active Power Filters for Line Conditioning: A Critical Evaluation" IEEE Trans on Power Delivery, Vol.15, No.1, pp.319-325, 2000.
- [3] Joseph S. Subjak, JR and John S. Mcquilkin "Harmonics- Causes, Effects, Measurements, and Analysis: An Update" IEEE Trans on Industry Appl, Vol.26, No.6, pp.1034-1042, 1990.
- [4] W.M.Grady, M.J.Samotyj, A.H. Noyola "Survey of Active Power Line Conditioning Methodologies IEEE Trans on Power Delivery, Vol.5, No.3, pp.1536-1542, 1990.
- [5] M.Kale and E.Ozdemir "An adaptive hysteresis band currentcontroller for shunt active power filter" Electrical power systemresearch. 74,pp 113-119,2005.
- [6] Brod D.M, Novotny D.M "Current control of VSI-PWM Inverter"- IEEE Trans on Industry Appl, Vol.21, pp.562-570, 1985.
- [7] Bhim Singh, Kamal Al-Haddad and Ambrish Chands "A Review of Active Filters for Power Quality Improvements" IEEE Trans on Industrial Electronics, Vol.46, No.5, pp. 960-970, Oct-1999.
- [8] Prasad N. Enjeti, Wajiha Shireen, Paul Packebush and Ira J. Pital "Analysis and Design of a New Active Power Filter to Cancel Neutral Current Harmonics in Three-phase Four-Wire Electric Distribution Systems" IEEE Trans on Industryappl, Vol.30, No.6, Nov/Dec-1994.