

Analysis of Intracardiac Masses in Heart by Applying Different Algorithms into Echocardiography

S. Sarmila Mercy¹, C. Rajarajachozhan²

PG Scholar, Department of ECE, M.Kumarasamy College of Engineering, Karur, India¹

Assistant Professor, Department of ECE, M.Kumarasamy College of Engineering, Karur, India²

Abstract: Generally, humans are suffered from various types of diseases. In recent years most of the people affected by cancer. Image processing is the key stage to recover the cancer patients at an early stage. The exact position of the tumor and thrombus using image processing techniques are found. According to the location of the tumor and thrombus, various diagnostic techniques are used. Various image processing techniques are helpful to automatically identify the intracardiac masses such as tumor and thrombus present in the heart. In this paper, various classification algorithms, various segmentation techniques, various denoising methods are analyzed. The comparative study was taken from various locations of the tumor and thrombus, present in the human's heart. Similarly, this paper gives the usage of different segmentation techniques and denoising approaches. In this study gives the knowledge about various filters, for reducing the noise in the images.

Keywords: Classification, intracardiac masses, sparse representation, tumor, denoising filters, thrombus.

I. INTRODUCTION

In general cardiovascular tumors can be cancerous or non- cancerous. Most of the primary tumor, they enter into the heart then growing in the heart and remains there. Secondary tumors are developing in another part of the body and then jump into the heart [3]. Most cardiac tumors are benign. Depends upon the location and size of the benign tumors can cause problems. On occurrence, thin portion of cancer rolls into the bloodstream and are taken to different blood vessels and block the way of blood flow to power organs called as an embolism. Both tumor and thrombus are the two main types of an intracardiac mass present in the human's heart. The most common type of primary cardiac tumor is Myxoma. Frequently, the tumor begins in the left upper chamber of the heart at the atrial septum, and that presents the two upper chambers of the heart. Rare development of myxomas can be started in other areas of the heart or heart valves. All over 10% of myxomas are genetic or created due to various sicknesses. Malignant primary tumors give pericardial mesothelioma, lymphoma, and sarcoma. Secondary cardiovascular tumors are considerably more common than essential tumors. The secondary tumors don't start in the heart; it jumps into the heart in the wake of developments in another range of the body. Generally, these cancers start and grow in the lungs, breasts, stomach, kidneys or liver. The tumors are identified to lymphoma, leukemia or melanoma. Intracardiac masses such as tumor and thrombus are very dangerous in cardiovascular infection. The most part of the intracardiac masses is abnormal in the structure inside or quickly neighboring to the heart, which must be recognized for further findings [5]. To avoid the sudden death of humanity due to embolization, cancer needs to be removed immediately. The thrombus is a fibrous clot that makes in the blood vessel or that forms in one of the chambers of the heart.

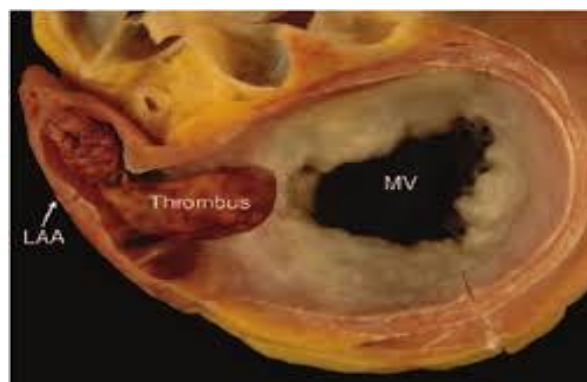

Fig.1. Intracardiac Thrombus

Arterial thrombi and venous thrombi these are the two different types of thrombi can be formed. Using the algorithm to reconstruct the images of the heart, echocardiography uses probes that produce sound focused on cardiac structures returning ultrasound signals are received through the probe and the computer in the ultrasound system. The high-frequency sound waves are used for viewing the internal part of the human body. Using probes in echocardiography, Cardiac structures returning ultrasound signals directed from the heart.

The patient, who affected from the stroke that is predicted with the help of ultrasound images [6]. To find the diameter, volume and vascular of a tumor's blood and other fluids, the processing and analysis can be used. The comparison made from intracardiac masses, the movement of the tumor is high at the same time there is no movement in thrombi, as shown in Fig.2.



Fig.2. Intracardiac tumor

In medical applications, the videos are manually examined by the specialists to find the contours of the intracardiac tumor and thrombus present in the echocardiography sequences of the heart. According to the specialists experience the time consumption of the segmentation process varies. Manual error occurs due to compression of masses and also blurring or missing boundaries.

To reduce the manual error due to noisy images, further, the requirement for an automated identification in intracardiac masses is rising, and it is very important to enhance the analysis accuracy to find out which oncological patients would counsel for a surgery. A complete automatic classification method has not been previously used to distinguish an intracardiac mass in echocardiograms. The various intracardiac masses are segregated and divided by using a neural network in echocardiography sequences of the heart in a semi-automatic way. A complete automatic classification method consists of four stages. This process involves despeckling, segmentation, feature extraction, and classification. To decrease the speckle present in the ultrasound image, filters such as median and speckle reduction of anisotropic diffusion filter are used. The level set method and active contour model are utilized for the segmentation of tumor and thrombi. The multilayer feed-forward artificial neural network, the back propagation neural network, the support vector machine are used for computer-aided identification of masses. This type of identifiers desires training phase and control from a qualified doctor. Hence, the sparse representation classifier is used.

II.PREVIOUS WORKS

A. Analyzing of Sparse Representation classifier and Support-Vector Machine

Myocardial ischemia occurs when blood flow to the heart is reduced, preventing it from receiving enough oxygen. The reduced blood flow is usually the result of a partial or complete blockage of your heart's coronary arteries. A sudden, severe blockage of a coronary artery can lead to a heart attack. For identifying myocardial ischemia, two automatic methods are introduced, which can be examined that as the initial sign of intense cardiovascular possibility. Myocardial ischemia generally shows as ST - wave and T-wave variations on Echocardiography signals. The strategies in this investigation are planned to distinguish unusual Electrocardiography heart beats utilizing knowledge-based features and identification techniques. Sparse Representation Classifier is a novel classification technique, which is used for improving the functioning of existing algorithms. An investigation was made between two classifiers namely, Sparse Representation Classifier (SRC) and support-vector machine (SVM), utilizing standard dependent vectors. Both techniques are proposed with computable assessment for approving their exhibitions. The outcomes of Sparse Representation Classifier approach enclosed through formula-based appearance establish larger sensitivity than that of Support Vector Machine. On the other hand relevance and correctness is an arrangement. Likewise, Sparse Representation Classifier technique does not depend upon the selection of formula-based appearance and can acquire higher achievement adopting insufficient appearance [5].

B. Kernel Sparse Representation Based Classification of Intracardiac masses

Sparse Representation Classifier is not a parametric study strategy. Performance of the SRC method is equivalent to nearest neighbor and nearest subspace methods. In these methods, it doesn't need a training process for assigning a class tag to a check pattern and as well as doesn't use a set of inference behavior to study the specification (e.g., weight vector) of the inference behavior. At Sparse Representation Classifier, the classification is done by applying signal restoration approaches. According to this conclusion, Sparse Representation Classifier can be the best sequence of deep machine learning and compressed sensing. The possible projection methods such as Kernel Principal Component Analysis, Kernel Fisher Discriminant Analysis, and even random projection could be used. For human frontal face recognition, Sparse Representation Classifier has been applied successfully. They experimentally show that Sparse Representation Classifier has given perfect identification achievement compared to the nearest neighbor and nearest subspace on face data. Kernel Sparse Representation Classifier is well performed while comparative analysis taken from nonparametric learning methods such as KNN, NS, SRC [3].

C. Rayleigh-trimmed anisotropic diffusion filter

From ultrasound images, Speckle is the major source of noise that produces deep Signal to Noise Ratio in Magnetic resonance images. To suppress the speckle noise in ultrasound images a new strategy is introduced. Two major components of this method: a Rayleigh-trimmed filter and anisotropic diffusion filter. Based on Rayleigh distribution of speckle, the Rayleigh-trimmed filter is introduced to decrease the primary noise.

To make the filtering result more robust, the anisotropic diffusion filter is functioned to get the region of images that gradients are anisotropic. Then extend the novel strategy to the three-dimensional space with the time like the third dimension. While retaining important features the novel strategy is efficiently using the statistical characteristics of speckle noise and suppresses speckle noise significantly. While improving the edge information and smoothing the speckle noise in ultrasound image videos, the proposed method is more effective. Performance elements, such as SNR ratio, CNR ratio and Figure of Merit are calculated for each and every image. The above analysis gives noise or speckle level in an image [2].

D. Biomedical Image Super-Resolution through Sparse Representation classifier

This paper is based on sparse signal representation, which introduces a novel method to single image super-resolution. Image pixels could be well-expressed, like a rare combination of components obtained from a particular selected over-entire dictionary, when an analysis taken from an image statistics. To convert the Low-resolution input to generate a High-resolution output, in which sparse representation is used for each patch.

The sparse representation can be exactly replaced by the downsampled signals covered by soft conditions. We can accomplish the likeness of thin representations both the under-resolution and over-resolution image patch combination according to their inherent dictionaries, while joint training the two dictionaries. Therefore, to generate an over-resolution image patch pair in sparse representation, the under-resolution image patch will be applied with over-resolution image patch dictionary. Compared to previous methods, this dictionary pair is a more compact representation of image patch combinations, which easily sample a higher amount of image patch combinations and also minimizing the operational cost. For both common image super-resolution (SR) and the special case of face vision, sparsity prior is exhibited effectively. [4]

E. Brain Tumor Segmentation Using Convolutional Neural Networks in MRI Images

Glioma is a type of tumor that affects the brain or spine. It is known as gliomas because it arises from glial cells and also it grows from glial cells. Among brain tumors, gliomas are the most common and dangerous that leading to a death. Treatment of brain gliomas, it depends upon the location, cell type and the level of malignancy. Frequently, the treatment is a combined method, using chemotherapy, radiation therapy, and surgery. To improve the critical condition of the oncological patients, the early stage of a treatment process is the key stage for recovering the patients. To estimate these tumors the Magnetic Resonance Imaging (MRI) imaging technique is frequently used. Sometimes magnetic resonance imaging halts the manual segmentation in an allowable time, limiting the use of accurate measurements in the medical investigation. The requirement of an automatic segmentation method arises, to solve the issues in a manual segmentation of the tumor. In this paper, Convolutional Neural Network (CNN) is used for segmenting the brain tumor cells automatically by examining the little 3*3 pieces. For proposing a deep architecture by utilizing the little pieces of brain tumor cells, away from developing a confident effect opposing overfitting, and also disposed an insufficient amount of load to the system. To improve the particular features of the input, during a training phase, weights of the kernels are adapted by using backpropagation, as shown in Fig.3.

Convolutional neural network having a benefit or getting a part of development outcome and achieve prominent discussions. Data augmentation method was also effective while learning the methods for brain tumor segmentation. Therefore, using the convolutional neural network able to decrease the computation time [1].

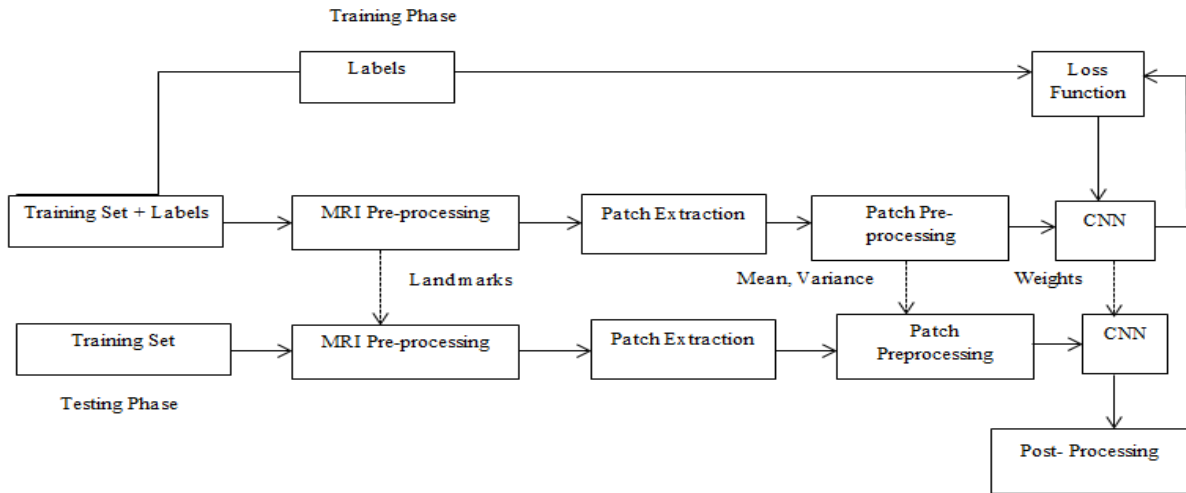

Fig.3. Convolutional Neural Network

TABLE I
COMPARISON of DIFFERENT ALGORITHMS

NO	Methodology	Advantages	Disadvantages
1.	Comparison of SVM and SRC ^[5]	Sensitivity is high as well as Errors and Complexity can be minimized	Not an adaptive method
2.	Kernel Sparse Representation-Based Classifier ^[3]	Compared to SRC, Kernel Sparse Representation Classifier have a faster test performance	Time consuming
3.	Rayleigh-trimmed anisotropic diffusion filter ^[2]	Smoothing the speckle noise and more robust	Efficient despeckling is demanding prior to other image processing strategies achieved from ultrasound images
4.	Biomedical Image Super-Resolution Via Sparse Representation ^[4]	Sparsity prior is very effective and reduces the RMS error	Determine the Optimal Dictionary size for natural image patches
5.	Segmentation based on Convolutional Neural Networks in MRI Images ^[1]	Good quality segmentation can capture more details and reduce the computation time.	Poorer presentation produced due to the narrower architecture of the tissues

III. CONCLUSION

This analysis gives knowledge about various methods used for segmentation of tumors present in the heart. It locates the exact position of the tumor by using these methods. Some automatic identification methods are used to identify the tumor and thrombus in the heart using echocardiography. By using an automatic method, it will take less time for identifying the tumor. The comparative analysis taken from classifiers, sparse representation classifier gives better performance and accurate results. The above analysis becomes useful for further investigation on an identification of intracardiac masses present in the echocardiography sequences of the heart. So this may be helpful to save the human's life in an earlier stage.

ACKNOWLEDGMENT

The creators might want to thank the unknown commentators for their important remarks and recommendations.

REFERENCES

- [1] Sérgio Pereira, Adriano Pinto, Victor Alves, and Carlos A. Silva, "Brain Tumor Segmentation Using Convolutional Neural Networks in MRI Images," *IEEE Trans. medical imaging*, VOL. 35, no. 5, MAY 2016.
- [2] Y. Deng, Y. Wang, Y. Shen, "Speckle reduction of ultrasound images based on Rayleigh trimmed anisotropic diffusion filter," *Pat. Recog. Lett.*, vol. 32, no. 13, pp.1516-1525, Oct. 2011.
- [3] Li Zhang, IEEE, Wei-Da Zhou, Pei-Chann Chang, Jing Liu, Zhe Yan, Ting Wang, and Fan-Zhang Li "Kernel Sparse Representation-Based Classifier" *IEEE TRANSACTIONS ON SIGNAL PROCESSING*, VOL. 60, NO. 4, APRIL 2012.
- [4] J. Yang, J. Wright, T. Huang, Y. Ma, "Image Super-Resolution via Sparse Representation," *IEEE Trans. Image Process.*, vol. 19, no. 11, pp. 2861-2873, Nov. 2010.
- [5] Yi-Li Tseng, Keng-Sheng Lin and Fu-Shan Jaw "Comparison of Support-Vector Machine and Sparse Representation Using a Modified Rule-Based Method for Automated Myocardial Ischemia Detection" Hindawi Publishing Corporation Computational and Mathematical Methods in Medicine Volume 2016, Article ID 9460375, 8 pages
- [6] S. Oh, M. S. Lee, B. Zhang, "Ensemble Learning with Active Example Selection for Imbalanced Biomedical Data Classification." *IEEE Trans. Comput. Biol. Bioinform.*, vol. 8, no. 2, pp. 316-325, Mar. 2011.
- [7] J. Garcia, L. S'ormmo, S. Olmos, and P. Laguna, "Automatic detection of ST-T complex changes on the ECG using filtered RMS difference series: application to ambulatory ischemia monitoring," *IEEE Transactions on Biomedical Engineering*, vol.47, no. 9, pp. 1195-1201, 2000.
- [8] Y. Li, Z. L. Yu, N. Bi, Y. Xu, Z. Gu, and S.I. Amari, "Sparse representation for brain signal processing: a tutorial on methods and applications," *IEEE Signal Processing Magazine*, vol. 31, no.3, pp. 96-106, 2014.
- [9] P. Dvorák and B. Menze, "Structured prediction with convolutional neural networks for multimodal brain tumor segmentation," *MICCAI Multimodal Brain Tumor Segmentation Challenge (BraTS)*, pp. 13-24, 2015.
- [10] L. Zhang, W. D. Zhou, and L. C. Jiao, "Support vector machines based on the orthogonal projection kernel of father wavelet," *Int. J. Comput. Intell. Appl.*, vol. 5, no. 3, pp. 283-303, 2005.
- [11] M. A. T. Figueiredo, R. D. Nowak, and S. J. Wright, "Gradient projection for sparse reconstruction: Application to compressed sensing and other inverse problems," *IEEE J. Sel. Topics Signal Proc.: Special Issue Convex Optimiz. Method. Signal Process.*, vol. 1, no. 4, pp. 586-598, Aug. 2007.
- [12] Loizou, C.P., Pattichis, C.S., Christodoulou, C.I., Istepanian, R.S.H., Pantziaris, M., Nicolaides, A., 2005. Comparative evaluation of despeckle filtering in ultrasound imaging of the carotid artery. *IEEE Trans. Ultrason., Ferroelect., Freq. Contr.* 52(10), 1653-1669.
- [13] Gupta, N., Swamy, M.N.S., Plotkin, E., 2005. Despeckling of medical ultrasound images using data and rate adaptive lossy compression. *IEEE Trans. Med. Imag.* 24 (6), 743-754.
- [14] J. H. Noble and B. M. Dawant, "Automatic segmentation of the optic nerves and chiasm in CT and MR using the atlas-navigated optimal medial axis and deformable-model algorithm," in *Proc. SPIE*, 2009, vol. 7259, pp. 725 916-1-725 916-10.
- [15] T. Kaneko, L. Gu, and H. Fujimoto, "Recognition of abdominal organs using 3D mathematical morphology," *Syst. Comput. Jpn.*, vol. 33, no.8, pp. 75-83, 2002.
- [16] Loizou, C.P., Pattichis, C.S., Christodoulou, C.I., Istepanian, R.S.H., Pantziaris, M., Nicolaides, A., 2005. Comparative evaluation of despeckle filtering in ultrasound imaging of the carotid artery. *IEEE Trans. Ultrason., Ferroelect., Freq. Contr.* 52 (10), 1653-1669.
- [17] K. Simonyan and A. Zisserman, Very deep convolutional networks for large-scale image recognition 2014 [Online]. Available: <http://arxiv.org/abs/1409.1556>, arXiv:1409.1556v6
- [18] M. Lyksborg *et al.*, "An ensemble of 2d convolutional neural networks for tumor segmentation," in *Image Analysis*. New York: Springer, 2015, pp. 201-211.
- [19] A. Davy *et al.*, "Brain tumor segmentation with deep neural networks," *MICCAI Multimodal Brain Tumor Segmentation Challenge (BraTS)*, pp. 31-35, 2014.
- [20] A. Gooya *et al.*, "GLISTR: Glioma image segmentation and registration," *IEEE Trans. Med. Imag.*, vol. 31, no. 10, pp. 1941-1954, Oct. 2012.
- [21] D. Kwon *et al.*, "Combining generative models for multifocal gliomas segmentation and registration," in *Medical Image Computing and Comput.-Assisted Intervention-MICCAI 2014*. New York: Springer, 2014, pp. 763-770.
- [22] S. Bauer *et al.*, "A survey of MRI-based medical image analysis for brain tumor studies," *Phys. Med. Biol.*, vol. 58, no. 13, pp. 97-129, 2013.
- [23] D. N. Louis *et al.*, "The 2007 WHO classification of tumours of the central nervous system," *Acta Neuropathologica*, vol. 114, no. 2, pp. 97-109, 2007.
- [24] E. G. Van Meir *et al.*, "Exciting new advances in neuro-oncology: The avenue to a cure for malignant glioma," *CA, Cancer J. Clinicians*, vol. 60, no. 3, pp. 166-193, 2010.