

Fruit Sorting and Packaging System

Darshana Fandade¹, Aboli Nugurwar², Anjali Shrekar³, Jotsna Nikhade⁴

Student, Electronics and Telecommunication, S.B. Jain Institute of Technology, Management and Research, Nagpur¹⁻⁴

Abstract: This paper aims at presenting the automatic system of fruit sorting and packaging which detects the fruits on the basis of spot detection by the Matlab software by the aid of the image processing. Image capturing and detection and packaging are key factors on which this system depends. This system will lead to the relaxation from the monotonous human work, will also minimize the error and speed up the process of sorting and packaging.

Keywords: sorting system, spot detection, image processing, sensors, conveyer belts, packaging, Matlab.

I.INTRODUCTION

Nowadays, in this 21st century where technology advances in order to reduce manual work in every domain. Even agriculture sector need to be focused on where more and more manual work is present. a person works 7 to 8 hours a day. This system would prove beneficial in agriculture sector too. The main objective of this project is to minimize the manual work and improve efficiency and also to reduce time consumption and make the process of fruit sorting and packaging automatic. At industrial level, when this system would be used, it will result in less time consumption, reduce error, will give a good efficiency in fruit sorting and packaging. This overall system is based on the Matlab software and consists of hardware too. Image processing is done by Matlab software whenever the fruit is detected and image is captured. hardware consist of conveyer belts, drivers and microcontroller and sensors. conveyer belts pass the fruits and packaging boxes at specified time and these are run by drivers by the command of microcontroller. sensors are present to sense the fruit and box. This also consist of LCD which displays the count of fruit and as well as of box. This system thus automate the process of fruit sorting and packaging. The fruits are passed by conveyer belt one by one and then in real time the fruit is sensed and image is captured and image processing is done by Matlab software and thus spot detection is done. then thus we get the result that whether the fruit is accepted or rejected. If accepted then the fruit is dropped in the packaging box which is passed by second conveyer belt and it stays there until and unless the specified amount of fruit get collected in it and if the fruit is rejected then the fruit is dropped at the other side with the help of shaft. This lead to the ease at meeting the requirement of customer and their satisfaction. because at the end any industry would aim to meet their customer need and to look after their requirements.

II.METHODOLOGY

The block diagram of automatic fruit sorting and packaging system is as follows:-

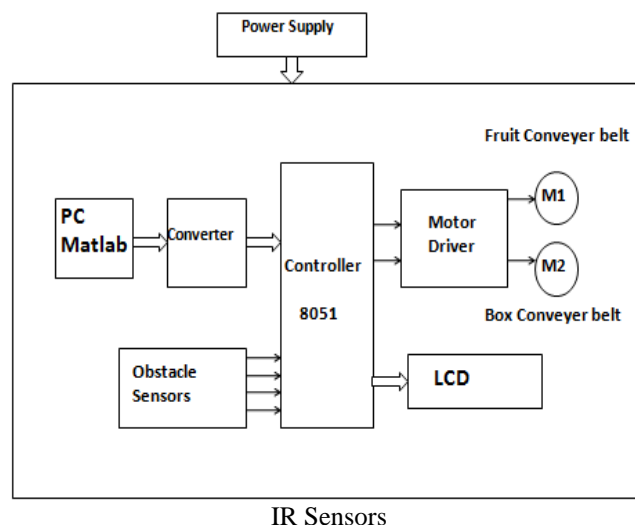

Here we have two IR based sensors, one for detecting fruit on the conveyor belt and the second is to detect the Box. First IR sensor detect the fruit on the conveyor belt and fruit count is incremented. Next, the second IR sensor detects the box on the conveyor belt and box count is incremented after the specific amount of fruits are dropped in the box.

LCD DISPLAY UNIT

Here we used a 16 character by 2 line display in our project. The main aim of using LCD is to display the Count of the fruits and box.

PC UNIT

In our project we are using MATLAB software on PC. The MATLAB will be doing the image processing of fruits for sorting them on the basis of spot detection.

DC MOTOR UNIT

We are using 12V DC motor to drive the DC motor based conveyor. The μC cannot provide the current required by the DC motor, so we interfaced DC motor driver L293D, which is used to drive the 12V DC Motor.

The process of the image captured by the camera and analyzing those features for sorting of the fruits is done by the MATLAB software. For transferring hex file into the controller we are using progISP software. And for designing a PCB layout of the final circuit of the system we are using Express PCB. We are designing a system which will automate fruit packing process with basic quality test and removal of the defected fruit from the conveyor. In our system we are using 2 obstacle sensors, 2 conveyor belt system, camera, motors and a PC. 2 conveyor belts are used for fruit and box movements while 2 obstacle sensors are used to detect the fruit and box and have a count of that. 2 motors are used of 3.5 rpm for running conveyor smoothly. Camera is used for taking image of the fruit and PC is used to do image processing and send result to the controller system. Initially when system is turned ON 1st Box is kept on the box conveyor belt and once it comes to the specific position that belt is stopped and then fruit belt is started. We have to just put fruit 1 by 1 on the belt and the system will scan whether fruit is ok or not if PC don't send any fault alert to the controller, controller keeps moving the fruit conveyor. At the end the fruit falls into the box and at the same time it is counted by using ir obstacle sensor. Once

pre defined count reached fruit belt is stopped and box belt starts to bring the next box for packing. In case a fruit is faulty then system sends alert to the controller system and at that time controller immediately stops the fruit conveyor and moves the shaft to remove that fruit from the belt. And fruit belt is started again for the next fruit cycle. In our system there are 2 conveyor belts. 1st Conveyor belt will be used for fruits where we have to put fruit 1 by 1. That fruit will be taken and dropped into the box for packaging. While going towards box, camera will keep taking images of fruit and image processing will be done to check whether fruit is of good quality or not. If fruit is of bad quality then conveyor belt will be stopped for removing fruit for some time and belt will start running again. 2nd belt is for box where box will remain at steady till 5 fruits are collected into it. Once box is filled with set amount of fruits box will be moved forward and next box will be brought to the previous location. In this way Fruit counting, Quality check will be done simultaneously and packaging process can be automated.

The flowchart of the system:

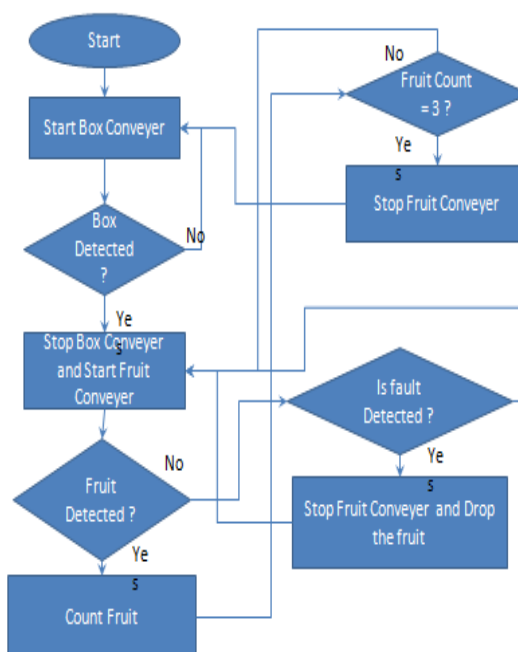

Algorithm 1: Identification and Classification of Fruits

Start

Step 1:

Read each image into the MATLAB from the particular folder of fruit dataset.

Step 2:

Convert the original image into grayscale image and binary image.

Step 3:

Filter the image using a median filter.

Step 4:

Remove or subtract the background from pre-processed image.

Step 5:

Filter the image using a median filter.

Step 6:

Calculate area of fruit image.

Step 7:

Calculate quality ratio $b=a/(x*y)$.

Step 8:

Apply condition if $(b > 0)$ fruit is defected

.else fruit is not defected

.end

Step 9: Finally, we are displaying various results.

Stop.

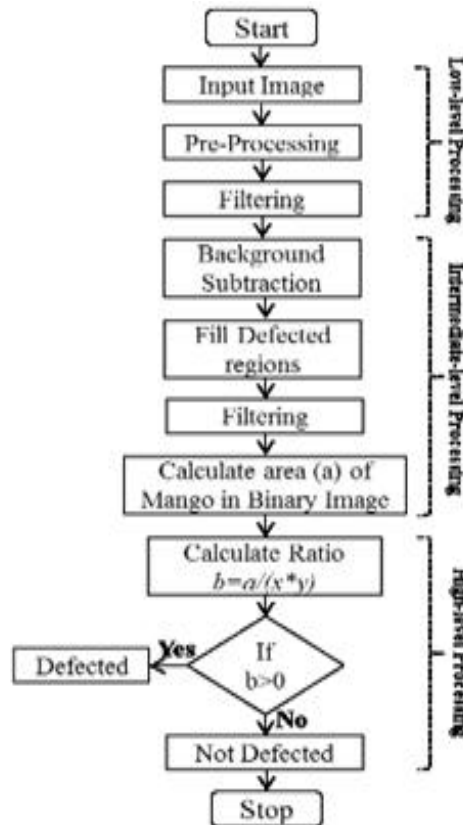

III. ACKNOWLEDGEMENTS

We thank our project guide Mr. Mayur B. Tembhurney for their valuable support and guidance.

IV.RESULT

As a result of this model design, the fruits with the black spots will be sorted and will lead to the supply of clean good quality fruits to the customer.



Figure shows the spotted fruits that got dropped off by the shaft while sorting the fruits.

V. CONCLUSION

The system which we proposed here is a model designed for decreasing the time consumption and the reduce the manual work and making the entire system automatic wherein the fruits will be automatically sorted on the basis of the spot detection by using image processing with the help of Matlab software and will be packaged thereafter leading to a step closer to meeting the consumer's satisfaction.

REFERENCES

- [1] A Fruit Quality Management System Based On Image Processing, Volume 8, Issue 6 (Nov– Dec 2013)
- [2] Quality measurement of fruits and vegetables, Judith A. Abbott Received 30 June 1998; accepted 11 November 1998
- [3] ARM Based Fruit Grading and Management System Using Image Processing Manoj B.Avhad 1, Satish M. Turkane 2. Volume 2, Issue 1 January 2013.
- [4] Rapid Color Grading for Fruit Quality Evaluation Using Direct Color Mapping, Published in Automation Science and Engineering, IEEE Transactions on (Volume:8 , Issue: 2) Date of Publication :15 November 2010
- [5] Dah-Jye Lee, Senior Member, IEEE, James K. Archibald, Senior Member, IEEE, and Guangming Xiong, Rapid Colour Grading for Fruit Quality Evaluation Using Direct Colour Mapping” IEEE Transactions On Automation Science and Engineering, Vol. 8, No. 2, April 2011.
- [6] Chandra Sekhar Nandi, Bipan Tudu, and Chiranjib Koley, Member, IEEE, “A Machine Vision-Based Maturity Prediction System for Sorting of Harvested Mangoes”, IEEE Transaction On Instrumentation and Measurement, Vol. 63, No. 7, July 2014.
- [7] Journal paper on “ARM Based Fruit Grading and Management System Using Image Processing” by Manoj B. Avhad , Satish M. Turkane, P.D.V.V.P's College of Engineering, Ahmednagar, Maharashtra, India, P.R.E.C Loni, Ahmednagar, Maharashtra, India in January 2013.
- [8] “Real Time Nondestructive Citrus Fruit Quality Monitoring System: Development and Laboratory Testing” by M.Yamakawa, L.R.Khot, R.Ehsani, N.Kondo (1.Division of Environmental Science and Technology, Kyoto University, Sakyo-ku, Kyoto, Japan; 2.University of Florida, IFAS, Citrus Research and Education Center, Lake Alfred, Florida, 33850, USA) in September 2012.
- [9] “Non destructive quality evaluation technology for fruits and vegetables using near infrared spectroscopy” by Kyu-Hong Choi, Kang-Jin Lee, Giyoung Kim (National Institute Agricultural Engineering, Rural Development Administration 249 Seododong, Suwon, Republic Of KOREA).