



# Energy Efficient Routing in Wireless Sensor Networks

Vishak.S.k<sup>1</sup> Geetha Ramani.J<sup>2</sup>

PG Scholar, Department of ECE, SNS College of Technology, Coimbatore<sup>1</sup>

Assistant Professor, Department of ECE, SNS College of Technology, Coimbatore<sup>2w</sup>

**Abstract** — The routing protocol Proposed for Wireless Sensor Network is hierarchical, homogenous and cluster based. After deployment of the Sensor Nodes entire sensor field is divided into different clusters and each cluster contains Sensor Nodes with different duties such as Gateway Node, Cluster Head Node and Ordinary Sensor Node. Majority of the computation intensive tasks are carried out in the Sink. Simulation works are done in NS2 tool. The performance of the proposed protocol has been compared with that of LEACH and results show better performance for the proposed protocol.

**Keywords-** Wireless Sensor Networks, Routing, Energy Efficiency

## I. INTRODUCTION

Sensors are devices that can detect a physical quantity and it converts it to a signal which can be read by an instrument. Physical quantity it can detect includes pressure, heat, light etc. Sensors uses wireless medium for transmission. The collection of sensor nodes in a wireless network is known as wireless sensor networks.

Routing in Wireless Sensor Network (WSN) is a highly challenging task and it becomes more challenging when movement of Sensor Nodes as well as the Sink is considered. The Wireless Sensor Networks suffer from several constraints and challenges and some of those are:

The sensor nodes are resource constrained e.g., limited power in the sensor nodes which are battery driven, limited onboard memory and limited processing capability of the sensor nodes, limited communication bandwidth etc.

The topology of the sensor network is highly dynamic due to frequent death of the sensor nodes; moreover while the movement of sensor nodes as well as the sink is considered the communication link up and down

Phenomenon becomes very frequent and it leads to highly dynamic topology.

Link failure may occur even during data transmission because of collision, death of node due to no battery supply, busy node and other events. This leads to retransmission of data packets and thus causes more energy expenditure. Movement of sensor nodes and the sink may cause link failure against some existing point-to-point links. Moreover sensor node mobility generates channel fading (a Physical Layer phenomenon) during data transmission and this degrades the performance of the network in terms of Bit Error Rate and Frame Error Rate.

Heavy traffic through some particular nodes may lead to quick depletion of energy in those nodes which may lead to death of those nodes in near future and thus may cause network reorganization. Unbalanced load in the sensor nodes is another cause of early death of some nodes.

This paper introduces a novel routing protocol for a mobile Wireless Sensor Network in which sensor nodes and the Sink are mobile. The proposed protocol is hierarchical and cluster based in nature. The paper considers a unique organization of the sensor network in the field which leads to a scalable and energy efficient solution regarding routing in mobile WSN environment. The proposed protocol is compared with LEACH protocol.

The rest of the paper is arranged as follows: Section II Mentions about some related work to this proposed protocol followed by Section III where the proposed protocol is described in detail. Section IV presents the simulation results and Section V summarizes the paper with a conclusion of this work.

## II. RELATED WORK

There are several routing protocols proposed for static

WSN in which the Sensor Nodes are static. For example, LEACH [2], PEGASIS [3], TEEN [4], APTEEN [5], LEACH-C [6], SONS [7] are some representative hierarchical routing protocols for WSN in which both Sensor Nodes and the Sink are static. LEACH-Mobile proposed in [8] is able to support mobility in Sensor Nodes by adding its membership declaration to the LEACH protocol [2].

CBR Mobile WSN proposed in [1] is another improvement over LEACH-Mobile [8] which strives to reduce packet loss and energy consumption in comparison to LEACH-Mobile. Though LEACH-Mobile and CBR Mobile WSN support movement of sensor nodes, they consider the Sink to be static.

**III. PROPOSED PROTOCOL**

The proposed protocol is hierarchical in nature and the entire protocol is consisting of two phases namely *Setup Phase* and *Data Forwarding Phase*. During the *Setup Phase* the self organization of the sensor field takes and the topology of the network is constructed. Total sensor field is logically divided into some clusters. Each cluster contains one Gateway Node, two Cluster Head Nodes and the remaining as Ordinary Sensor Nodes as in Fig. 1. During the *Data Forwarding Phase* actual routing of data takes place and the routes are decided as per the roles of the nodes in the sensor field (i.e., Gateway Node, Cluster Head Node, and Ordinary Sensor Node). The responsibility of the Ordinary Sensor Node is to sense the environment and forward the sensed data towards the Cluster Head Node. The Cluster Head Node in turn forwards the collected data towards the Gateway Node inside the same cluster and finally the Gateway Node is responsible for forwarding the data towards the Sink either directly or indirectly via some other Gateway Node present in other clusters. The Cluster Head Nodes as well as the Gateway Node do the data fusion in order to reduce the volume of data to be transmitted by removing redundant information but without losing useful information. The two Cluster Head nodes present inside each cluster have respective set of Ordinary Sensor Nodes as their subordinate nodes as shown in Figure 1. Figure 2 shows sensor nodes with different roles and the communication hierarchy considered in this protocol.

**Cluster Formation:** The Sink carries out the clustering of the sensor nodes after deployment of the sensor nodes in the field. The details of the clustering algorithm are not considered in this paper. It has been assumed that the Sink forms geographically uniformly distributed clusters in the sensor field

**Gateway Node Selection:** The Gateway Node is responsible for gathering data from the two Cluster Head Nodes and then forwarding the data towards the Base Station. Therefore it is essential that the Gateway Node remains connected to the Cluster Head Nodes with higher probability throughout the Cycle.

Figure 1 A Typical Cluster in the WSN field

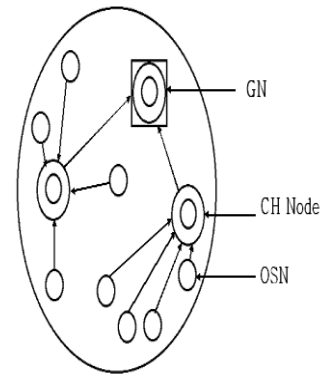

Figure 1 A Typical Cluster in the WSN field

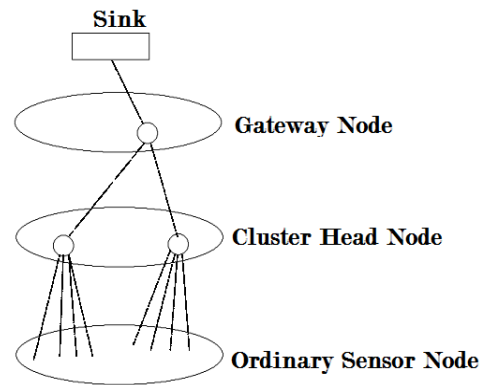

Figure 2 Various Roles and the Communication Hierarchy inside a Cluster

**Cluster Head Node Selection:** The Base Station selects two Cluster Head nodes for each cluster. The idea behind selecting two Cluster Head nodes for each cluster is to reduce the bottleneck at one central node as it is in conventional cluster based protocols, in which only one node acts as the Cluster Head. Another objective behind considering two Cluster Head Nodes inside the same cluster is to maintain connectivity inside the clusters in spite of the mobility of the nodes. The Base Station collects the location information from each node inside each cluster. The two cluster head nodes are expected to be geographically uniformly distributed so that coverage inside each cluster is optimum. Moreover the two Cluster Head nodes are expected to remain connected to the GN throughout a cycle. Therefore two Cluster Head nodes inside each cluster are selected in such a way that these two nodes jointly can cover the entire cluster. In other words it is



expected that all the Ordinary Sensor Nodes remain connected through their direct links at least to one of the two Cluster Head Nodes.

*Communication Pattern for Routing:* The Sink distributes the communication patterns for data forwarding for the Ordinary Sensor Nodes (OSN) inside the Clusters through the Cluster Heads (CH). The Cluster Head Nodes inside each Cluster carry out local data aggregation and forward data to the Gateway Node (GN) inside the same Cluster. The Gateway Node further forwards the data towards the Base Station and this is a long distance transmission of huge amount of data. The communication patterns for the Gateway Nodes are discovered in real time for a particular *duration t* and again may have to rediscover after *t* based on the moving Gateway Nodes' current locations. Since some Gateway Nodes shall reside far away from the Base Station it is going to be economic if transmission from these GN to the Sink is carried out in multi-hop fashion keeping some other GNs as intermediate hop [2]. At the same it is also to be considered that if some GN nearer to the Sink are made intermediate hop for many other distant GNs, then the nearer to the Sink GNs will deplete energy quickly due to the burden of relaying huge amount of data towards the Sink. Therefore a restriction has been put that a GN can not be an intermediate relaying hop for more than once.

*Medium Access Control Information:* The TDMA based time slots are assigned by the Cluster Heads for their respective subordinate nodes. Slot re-assignments may occur before re-clustering is called. This is mainly due to the sudden death of some Ordinary Sensor Nodes or another reason may be the movement of an OSN towards a corner or further point due to which the link with the Cluster Head breaks as the distance between the two exceeds the available radio range of the two. Similarly if this separation reduces a broken link may also come up after some time. Therefore time slot assignment is a regular phenomenon within the same cluster setup. It has been assumed that inside the same Cluster the two Cluster Head nodes use different coding schemes and two different Clusters use different frequency bands to limit inter-cluster interference. Similarly the Gateway Node distributes TDMA based medium access slots to the respective Cluster Head nodes and the Sink distributes medium access slots to the Gateway Nodes for data transmission.

*Mobility Management inside a Cluster:* Due to the mobility of the nodes as well as the Sink the circumstances under which routing of data is to be carried out are extreme. This makes the task of routing very complex. There may be frequent link break as well as up and this may lead to network partition which may instigate rerouting. The objective of the routing protocol should be to perform well in a given condition. In this protocol the mobility of the nodes as well as the sink are managed at the Gateway Node. One of the responsibilities of Gateway Node is to handle mobility in the

Network. Algorithm given below which executes at each Gateway Node describes the mechanism to handle the mobility of the nodes.

**Algorithm:**

INPUT: If the Cluster Head *h* does not receive packets from a node *i* during the expected time slot for two consecutive times then *h* informs the Gateway Node *g* by sending the following packet  $\langle i, (t_i, t_{i+1}), Loc_h \rangle$ ; Here *i* is the id of the missing node,  $(t_i, t_{i+1})$  are the time slots during which packets are not received,  $Loc_h$  is the current location of the Cluster Head.

Start

```

Step 1: g receives  $\langle i, (t_i, t_{i+1}), Loc_h \rangle$  from h
Step 2: g sends a <hello> packet to i and asks for its location after a regular interval of time till further notice and waits for <ack> from i
Step 3: if g receives  $\langle i, Loc_i \rangle$  update (status)i= up else (status)i=down
if (status)i= up
    {Step 4: g computes the distance dis between  $Loc_h$  and  $Loc_i$  and compare dis with the radio ranges of i and h.
    Step 5: if i is out of range
        then g signals h for slot reassignment and also signals i for stop transmission towards h
        else signal h to wait for data during the next expected slot of i.}
else
    {Step 6: signal h for slot reassignment}
Step 7: if g computes the location of i & h as within the radio range of each other
    then signal h to assign slot for i
    and
    also signal i to start transmission towards h
    and stop sending location to g

```

End

*Re-clustering :* The process of re-clustering may get initiated due to two major reasons. The first is, if the Cluster Head loses connectivity with most of the allocated cluster member nodes then throughput will suffer. This phenomenon may lead to re-clustering. The second reason may be expiry of the allocated time period (i.e., life time). When the Clusters are formed during the Setup Phase optimum time duration is fixed as the lifetime of the current cluster setup. This time duration is the maximum time limit for which a cluster set up is valid and this may be fixed by the application based on the sensor node battery specifications.

**Setup Phase and Data Forwarding Phase constitute the entire Protocol:** The entire protocol can be broadly divided into two phases namely *setup phase* and *data forwarding phase*. The duration of *setup phase* is very small in comparison to the length of *data forwarding phase*. During the *setup phase* different tasks such as clustering, role assignment, and medium access control information distribution are carried out. Before the data forwarding phase starts the sensor network is

organized and it is made ready for sensory data forwarding. As mentioned above a) Cluster Formation b) Gateway Node selection c) Cluster Head Node selection, d) Communication Pattern for Routing e) Medium Access Control Information, are different parts of the *setup phase*. Once the *setup phase* is over the actual data transmission towards the Base Station starts and continues till the end of the predefined time interval or till the exception condition like severe link break or node failure occurs. During the *data forwarding phase* the sensory data are forwarded towards the base station as per the routing policies made during the *setup phase*. While *data forwarding phase* is in progress, there can be node failure as well as link failure due to the death of nodes or mobility of the nodes. Therefore even during the *data forwarding phase* there is need to continuously check the network status and in presence of exception situation actions are to be taken so that the overall network throughput does not suffer. As mentioned above f) Mobility management inside a Cluster, and g) Re-clustering initiation, are various ongoing cluster management activities even during the data forwarding phase.

#### IV. SIMULATION RESULTS

The proposed protocol has been simulated through NS-2 tool and different parameters are calculated.

**Throughput:** It is ratio between the actual numbers of packets transmitted by the nodes in the system to the numbers of successfully delivered packets at the Sink. A protocol with higher throughput is desirable. Throughput is a measure of successful delivery of packets at the Sink and alternately it is also termed as *Successful Delivery Ratio (SDR)*.

**Network Life Time:** It is the time taken since the start of the network (*during the simulation*) for the first 10% of the total deployed nodes to die. A protocol with larger network life time is desirable.

**Average Control Overhead:** It is average (i.e., per node) of the total energy expenditure in the network system due to control message exchanges over a specific period of network operation time.

**Average Energy Consumption:** It is average (i.e., per node) of the total energy expenditure in the network system over a period to time. This energy expenditure includes all kinds of sources for energy consumption such as communication (control as well as data), computing, sensing, idle listening etc.

**Simulation Environment:** In our simulation experiment we consider different setup of the sensor network. In the first set of reading we vary the number of nodes deployed in the sensor network from 20 to 100. The nodes are randomly deployed over a field of dimension (210×210) meter square area. The base station is located in the left side of the sensor field. The radio transmission range of the sensor nodes is 100 meters. The sensor nodes move in random direction with a random value of speed in the range of (2-6) meter per second. Similarly the Base Station also moves with a speed from within the same range but within a specific geographic zone. In our simulation we compute the location of each of the

nodes after a regular interval of 120 seconds. We run the simulation for a period of 5400 seconds. All nodes are assumed to have equal amount of initial energy. The initial energy in each sensor node is considered to be 12 J. We use the same communication paradigm as described in [2] with respect to the energy expenditure against transmission and reception of data. The sensor nodes are considered to be constant bit rate source. During the simulation we assume that the nodes generate report only at a single rate such as one report per second or two reports per second. Each report is consists of 64 bytes or 512 bits. We assume a packet drop probability in the range of (0.0- 0.2) at each intermediate hop. We measure the throughput after every 200 seconds. Values taken for different parameters used in the energy expenditure computation is as mentioned in the TABLE 1.

TABLE 1

Parameter	Value
$E_{elec}$	40 nJ/bit
$\epsilon_{amp}$	10 pJ/bit/m <sup>2</sup>
$\gamma$	2
Radio range of nodes	100 m

#### Simulation Results:

In this section we present some results obtained through simulation. We also provide an analysis of the results. We compare the performance of the proposed protocol with LEACH in terms of *throughput*, *average energy consumption*, *average control overhead* and *network life time* against different sizes of the network.

Fig a shows the achieved throughput level of the proposed protocol and also of LEACH against different network size. It is observed that throughput level of both the protocols decrease along with the increase in the network size. But the proposed protocol outperforms LEACH with respect to throughput level under all circumstances.

Fig b shows delay in the network against different network sizes incurred by both the protocols. It is seen that the proposed protocol shows lesser delay than LEACH throughout.

Fig c shows the trend regarding energy used under the influence of both the protocols proposed one and the LEACH. The proposed protocol improves the life span of the network significantly than LEACH. It is also observed that for both the protocols, the life time of the network decreases along with the increase of the network size. This graceful degradation in the network life time is due to increased number of transmissions and receptions along with the growth of the network size.

V. SUMMARY AND CONCLUSION

We propose a routing protocol for wireless sensor network in which the sensor nodes as well are mobile. The proposed protocol is hierarchical in nature and cluster based. The proposed protocol reduces energy expenditure in the network and thus prolongs the life time of the network. It also minimizes the control overhead. The proposed protocol delivers data at the sink with a higher throughput level in spite of the mobility of the sensor nodes. The protocol takes care of the link failures and finds alternate routes in order to deliver data at the destination.

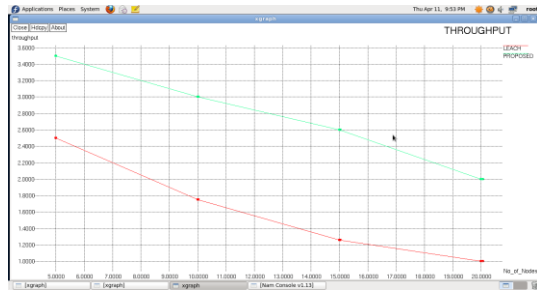

Throughput graph for different number of nodes



Delay graph for different number of nodes

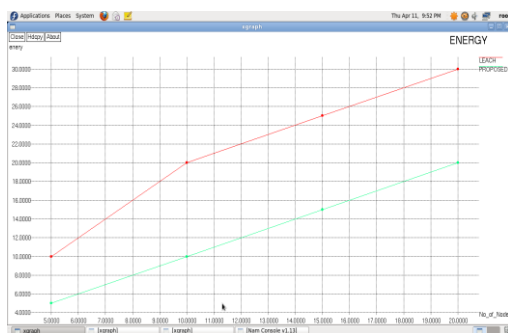

Energy used for different number of nodes

REFERENCES

- [1] Samer A. B. Awwad, Chee K. Ng, Nor K. Noordin, and Mohd. Fadlee A. Rasid, "Cluster Based Routing Protocol for Mobile Nodes in Wireless Sensor Network" *International Symposium on Collaborative Technologies and System 2009, (CTS 09)*, 18-22 May 2009, pp 233-24.
- [2] W. Heinzelman, A. Chandrakasan, and H. Balakrishnan, "Energy Efficient Communication Protocol for Wireless Microsensor Networks", in *Proc. of the 33rd Annual Hawaii International Conference on System Sciences (HICSS)*, IEEE Computer Society, Maui, Jan. 2000, pp 3005-3014.
- [3] S. Lindsey and C.S. Raghavendra, "PEGASIS: Power-Efficient Gathering in Sensor Information Systems" In *Proc. of IEEE ICC 2001*, vol. 3, Jun 2001, pp. 1125-1130.
- [4] A. Manjeshwar and D.P. Agarwal, "TEEN: a Routing Protocol for Enhanced Efficiency in Wireless Sensor Networks", in *Proc. of 1st Int'l Workshop on Parallel and Distributed Computing Issues in Wireless Networks and Mobile Computing*, San Francisco, USA, April 2001, pp 2009-2015.
- [5] A. Manjeshwar and D.P. Agarwal, "APTEEN: A Hybrid Protocol for Efficient Routing and Comprehensive Information Retrieval in Wireless Sensor Networks" In *Proc. of Int'l. Parallel and Distributed Processing Symposium (IPDPS)*, Fort Lauderdale, USA, 2002, pp 195-202.
- [6] W.B.Heinzelman, A.P. Chandrakasan, H.Balakrishnan, "An application-specific protocol architecture for wireless microsensor networks", *IEEE Transactions on Wireless Communications*, vol.1, no.4, 2002, pp 660-670.
- [7] Mohammad S. Al-Fares, Zhili Sun, Haitham Cruickshank, "A Hierarchical Routing Protocol for Survivability in Wireless Sensor Network (WSN)", in *Proc. of the International Multi Conference of Engineers and Computer Scientists (IMECS) 2009*, vol.1, Hong Kong, March 18-20, 2009.
- [8] Lan Tien Nguyen et al., "An Energy Efficient Routing Scheme for Mobile Wireless Sensor Networks", in *Proc. of IEEE ISWCS 2008*, pp 568-572.