

Smart Trolley with Instant Billing to Ease Queues at Shopping Malls using ARM7 LPC2148: A review

Mohit Kumar¹, Jaspreet Singh², Anju³, Varun Sanduja⁴

B.Tech, Chandigarh Group of Colleges Technical Campus, Jhanjeri, Mohali, Punjab, India^{1,2,3}

Assistant Professor (ECE Dept.), Chandigarh Group of Colleges Technical Campus, Jhanjeri, Mohali, Punjab, India⁴

Abstract: The modern technology has increased the standard of living for the humans. Every one of us craves for a quality in everything we use in our daily lives. So, this has resulted in large crowds at shopping malls which have lead to long lines at the billing counter because the cashier has to scan every product item and then enter it into the billing record. The prevailing billing system is a bit time consuming. So, we thought of inventing a remedial electronic product to catch-up with this problem. We call it “Smart Trolley with Instant Billing to Ease Queues at Shopping Malls using ARM7 LPC2148: A Review”. This is based on arm7 microcontroller fitted with a LCD and RFID scanner and a wireless technology called zigbee. The LCD used is a 16x2 and zigbee modules make the wireless network to work even at long distance due to its wide range. The brief description of its operation is, when you pick a product and drop it into the trolley, the RFID scanner scans the product’s unique code and its price. And it gets displayed on the LCD screen. So after costumer has finished with the shopping he/she has to visit the counter and pay the bill as displayed on the LCD screen fitted on the trolley. This will save the time that was earlier being consumed to scan each item.

Keywords: Smart trolley, digital trolley, ARM7 LPC2148, Zigbee, RFID, Instant billing.

I. INTRODUCTION

The name of the project is “Smart trolley with instant billing to ease queues at shopping malls using ARM7 LPC2148: A review”. This product is basically an embedded system that uses arm7 lpc2148 microcontroller. The motive of smart and quick billing is achieved by interfacing RFID and ZIGBEE module with the microcontroller. The further description of components is as follows [8]

A. ARM7 LPC2148

Arm7 LPC2148 is 64 pin and 32 bit memory storage microcontroller. It is multipurpose microcontroller used to perform different task. Due to its bitty size and low power utilization, ARM7 LPC2148 is good for applications where miniaturization is a key requirement, like uses control and sale. USB to SERIAL RS232 cable is used to connect it with the computer. RFID modules, LCD screen (16x2) and Zigbee are interfaced to the ARM7 LPC2148 microcontroller.fig.1 shows ARM7 LPC2148 [5].

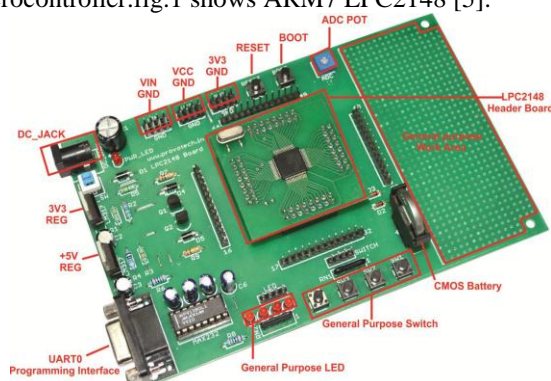

Fig.1 ARM7 LPC2148 board [5].

B. RFID

RFID stands for Radio-Frequency Identification. It is a small electronic device which reads the radio frequency and transfers the information to the device. The RFID device serves the same purpose as a bar code or a magnetic stick on the back of a credit card, ATM card etc. It provides a unique attribute for that object. And just as a bar code or magnetic stick must be scanned to get the information, the RFID device must be scanned to recover the identifying information. One of the main differences between RFID and barcode technology is RFID reject the need for line-of-sight reading on which bar coding depends. It can be seen in Fig.2 [6].

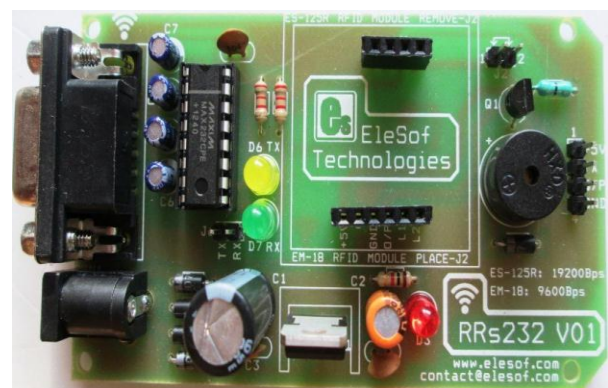

Fig.2 RFID Reader.[6]

RFID tags to be used are 125 KHz passive type tags. Transponder (tag) that is attached to the object. An RFID tag is composed of a microchip and antenna. RFID tags come in a wide variety of sizes, shapes, and forms. RFID tags have its own ID numbers and this RFID tag’s ID

coded in code with all information like price, product name etc. of that particular product.

C. Zigbee module

Zigbee is a low-cost, low-power, wireless web network. Zigbee devices can transmit data over long distances by passing data through a mesh network. Zigbee is typically used in low data rate applications that require long battery life and secure networking. The distances that can be achieved transmitting from one station to the next extend up to about 70 meters. It shows name of every item, its corresponding cost and the total bill of all products.[7] Check it in Fig.3[7].



Fig.3 Zigbee Module [7].

D. LCD

LCD is liquid crystal display and this technology used for displays in notebook and other smaller computers. LCD has the potentiality to display numbers and characters. In this it is displaying the product details like price, weight, discount etc.LCD (16x2) is used to display the details of product.

E. Software description

Keil version5 is used for the coding and flash magic is used to burn that code in the ARM7. Software named digi's X-CTU is used for connecting the zigbee module to the computer.

II. METHODOLOGY

Step 1:-Firstly connect ARM7 LPC2148 with pc through USB to Serial RS232 cable. Check connection in fig.4.

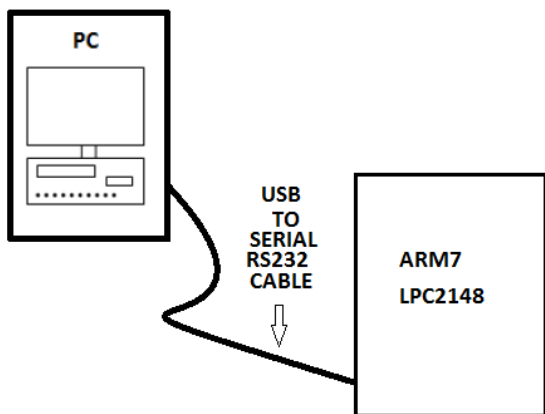

Fig.4 Connection b/w ARM7 LPC2148 and PC.

Step 2:-Secondly create the required code for displaying message in LCD for example “This is a 2x16 line LCD display”.(use Keil software for creation of code and use flash magic to burn this code)

Step 3:-Then interface ARM7 LPC2148 with LCD.Check the output in fig.5.

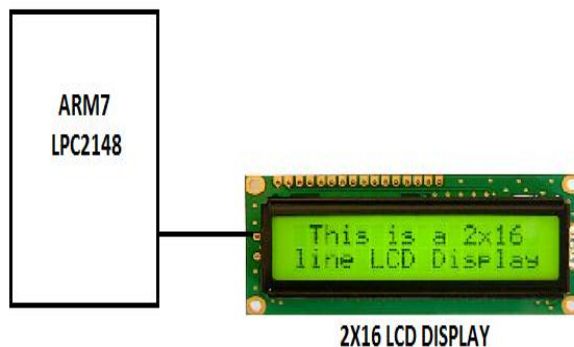

Fig.5 Interfacing of 2x16 LCD with ARM7 LPC2148.

Step 4:-Interface one zigbee with ARM7 LPC2148 and other zigbee with pc and then burn required code in ARM7 LPC2148.

Modes of zigbee:-

- a) Zigbee which is connected with arm7 act as both transmitter and receiver.
- b) Zigbee which is connected with pc act as both transmitter and receiver.

Check its block diagram in fig.6.

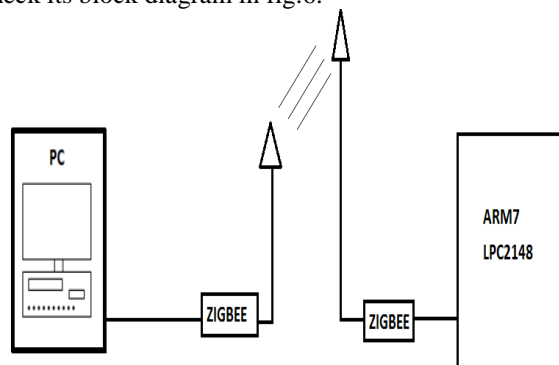

Fig.6 Interfacing of zigbee modules and ARM7 LPC2148.

Step 5:-Then interface RFID reader with ARM7 LPC2148 and then burn the required code in ARM7 LPC2148.

Then place RFID tag near the RFID reader and then the id is read by the reader and the detail is displayed on LCD.Check the related block diagram in fig.7.

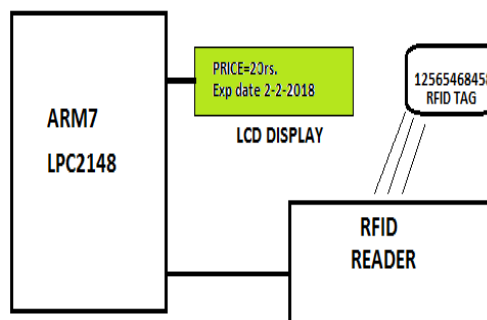

Fig.7 Interfacing of RFID Reader with ARM7 LPC2148.

Step 6:-At last interface RFID reader,LCD and zigbee with ARM7 LPC2148 and burn required code in ARM7 LPC2148.then place RFID tag near the RFID reader which reads the detail of the product like price, expiry date etc. and display the detail on LCD after that the information is transmitted to pc at counter through zigbee modules. Check final view of device in fig.8.

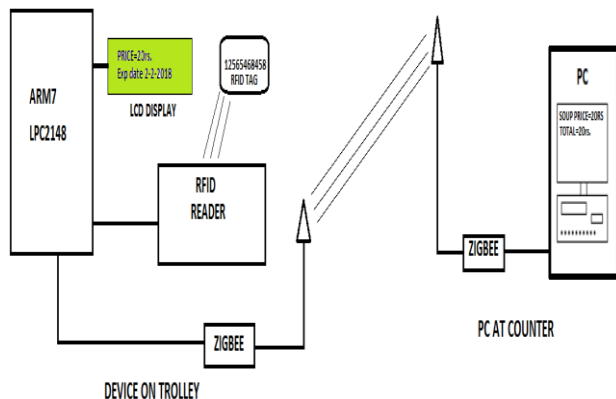
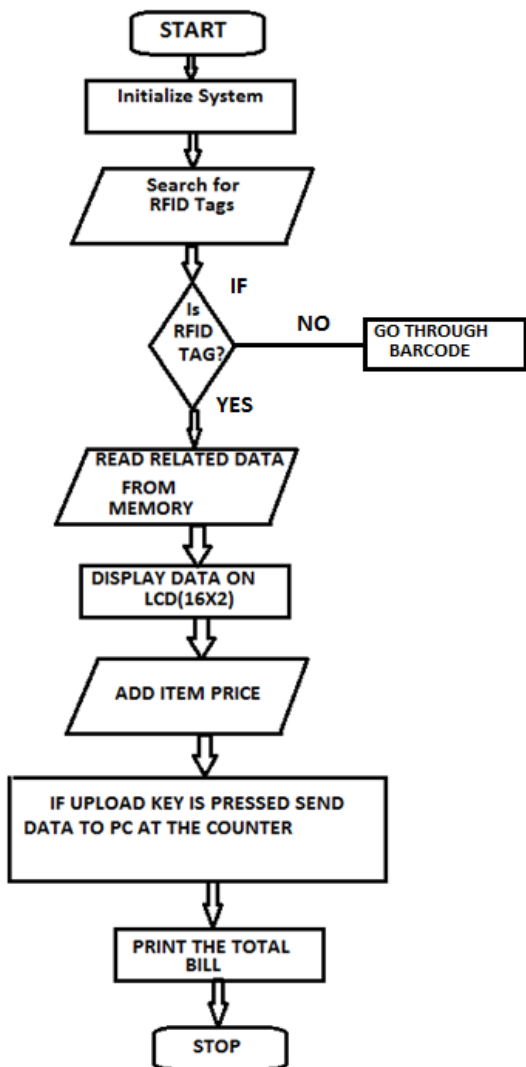

Fig.8 Final Device Arrangement.

A. Algorithm:



III. RELATED WORK

S Raghupati and V Karthikeyan proposed a project named as "Implementation of an efficient shopping technique with automatic billing through-CAST". CAST stands for Context aware shopping trolley, unique method to make the billing through net banking for both customer and supermarket. This project contains a touch screen mounted on trolley that is divided into two sections, shopping list and map where that product lies [1].

Another project was carried out by Satish kamble, Sachin Mishram Rahul, and Roshan Gakhre.They named it as "Developing a Multitasking Shopping Trolley Based on RFID Technics".They used a system that has three components SCC, UIDC and ABC.The SCC establish and maintains the connection of the shopping cart with the main screen.UIDC provides the user interface and the ABC handles the billing in association with SCC [2].

Varsha Jalkote, Alay Patel and his team implemented a project namely "Futuristic trolley for intelligent billing with amalgation of RFID and zigbee". And it uses ATMEL LAT24C04 to store the billing records and a 16x2 LCD to display the details of selected items. This project likewise others above mentioned also focus on providing easy shopping to costumers and avoiding large queues [3].

Similarly a project was proposed by Raju kumar, K gopalkrishna and K ramesha.This project was named as "Intelligent shopping cart". They also used a system that consists of three components i.e. SCC, UIDC and ABC as used above mentioned (in B).

During research related to this field several projects were seen and their main objective was to save time, avoid large queues and develop a user friendly smart shopping machine. Some of them are mentioned above [4].

IV. CONCLUSION

The introduction of this electronic product to the supermarkets will be a boon for shopping as it would make shopping easier. Now, the customer needs not to stand in a queue to pay the bill. This product makes billing automatic. The inspiration and idea of this paper was drawn from large queues at the shopping mall and the inconvenience that it causes to the costumers. This new system of billing is fast as the single product detail gets recorded as it is dropped into the trolley. Working on this product it was noted that RFID technology and ZIGBEE has a very vast applications in the near future. Also, RFID is better and faster than bar code reading because the later works on line of sight which is not the case for RFID technique.RFID technology is compact and reliable.ZIGBEE is the wireless network that connects the costumer to the retailer and is very secure with long range of operation. This intelligent shopping system can completely change the way of shopping. The RFID and ZIGBEE technologies that are not commonly used would definitely find some use commercially. Moreover, this smart trolley will be very beneficial as it would reduce the number of salesmen and billing counters and also prove to be time saver for both costumer and the shopkeeper.

REFERENCES

- [1]_S Raghupati and V Karthikeyan , *Implementation of an Efficient Shopping Technique with Automatic Billing Through-CAST*, *International Journal of Advanced Research in Computer and Communication Engineering* Vol. 2, Issue 3, March 2013.
- [2] Satish Kamble, Sachin Meshram, Rahul Thokal, Roshan Gakre, *Developing a Multitasking Shopping Trolley Based On RFID Technology*, *International Journal of Soft Computing and Engineering (IJSCE)* ISSN: 2231-2307, Volume-3, Issue-6, January 2014.
- [3] Varsha jalkote, Alay Patel and his team, *Futuristic Trolley for Intelligent Billing with Amalgamation of RFID and ZIGBEE*, *International Journal of computer application*(0975-8887), International conference on recent trends in engineering and technology.
- [4] Raju kumar, K gopalkrishna and K ramesha, *Intelligent Shopping Cart*, *International Journal of Engineering Science and Innovative Technology (IJESIT)* Volume 2, Issue 4, July 2013.
- [5]. <https://www.facebook.com/photo.php?fbid=1009026449132089&set=a.189350791099663.45133.100000742305815&type=1&theater>
- [6]. https://www.google.co.in/search?q=RFID+reader+ELESOF&biw=1366&bih=667&source=lnms&tbn=isch&sa=X&ved=0CAYQ_AUoAWoVChMI8eO35u_6xgIVhwqOCh2vVAqG
- [7]. https://www.google.co.in/search?q=RFID+reader+ELESOF&biw=1366&bih=667&source=lnms&tbn=isch&sa=X&ved=0CAYQ_AUoAWoVChMI8eO35u_6xgIVhwqOCh2vVAqG#tbn=isch&q=ZIGBEE+MODULE+DIGI
- [8]. <http://www.sharpsma.com/download/ARM7-TRMpdf>

BIOGRAPHIES



MOHIT KUMAR, pursuing (7th sem) B.tech/B.E degrees in Electronic and communication Engineering from Chandigarh Group of Colleges Technical campus, Jhanjeri, Mohali (PUNJAB).



JASPREET SINGH, pursuing (7th sem) B.tech/B.E degrees in Electronic and communication Engineering from Chandigarh Group of Colleges Technical campus, Jhanjeri, Mohali (PUNJAB).



ANJU, pursuing (7th sem) B.tech/B.E degree in Computer Science Engineering from Chandigarh Group of Colleges Technical Campus, Jhanjeri, Mohali (PUNJAB).



VARUN SANDUJA was born in Hisar (Haryana). He has done his Diploma in Electronics and Communication Engineering from Desh Bhagat Polytechnic College, Dhuri (Punjab) in 2008. He has completed his B.tech and M-tech in Electronics and Communication Engineering from Lovely Professional University, Jalandhar (Punjab) in 2012. His research interest includes Embedded System, Image Processing, Signal Processing, Wavelets, Cryptography and Wireless Communication.