

Optimum Placement of D-STATCOM using Firefly Algorithm for Enhancing Power Quality

Chaithra C¹, Padmaja K²

PG Scholar, Department of EEE, Acharya Institute of Technology, Bengaluru, India ¹

Assistant Professor, Department of EEE, Acharya Institute of Tehnology, Bengaluru, India ²

Abstract: Using Firefly Algorithm (FA), to optimally place the Distribution Static Synchronous Compensator (DSTATCOM) in a distribution system for enhancing power quality. In this method, the average voltage total harmonic distortion (THDV), average voltage deviation and total investment cost are considered as the objective functions, where voltage and power limits for individual buses are consider as the optimization constraints. The performance of the proposed FA is investigated using the Matlab software on the radial IEEE 16bus test system. The simulation results verify the ability of FA in accurately determining the optimal location and size of the D-STATCOM in radial distribution systems.

Keywords: D-STATCOM, Optimal placement, firefly algorithm, Voltage sag.

I. INTRODUCTION

In power system causes some issues are the power quality disturbances, voltage variation, voltage sag and harmonic distortion can cause interruption in the processing plants and financial losses. Hence, the best solution to mitigate power quality disturbances, especially voltage sag and harmonic distortion and to protect sensitive equipment is to install proper types of custom power devices (CPDs) such as the Distribution Static Synchronous Compensator (D-STATCOM) [1]. The mitigation option, location, and sizing of the required CPDs should be wisely determined based on the technical and economic feasibilities using proper optimization process. Presently, numerous optimization based techniques have been proposed to solve the optimal lacement and sizing problems of CPDs. A genetic algorithm (GA)-based optimization technique was used to optimally place a dynamic voltage restorer and a thyristor voltage regulator to minimize the total power quality cost due to occurrence of voltage sag [2]. An improved GA method using the niching GA was then developed to explore a wider search space and improve the optimization process [3]. The gravitational search algorithm has been applied to improve the sag performance of a power system by means of optimal placement of D-STATCOM [4]. In addition to the CPDs, other devices such as distributed generators and capacitor banks have also been considered to optimally improve the power quality of a system using particle swarm optimization (PSO) [5], and so on.

In this paper, a recent heuristic optimization technique called Firefly algorithm (FA) is applied to determine the optimal size and location of D-STATCOM for improving power quality of a system. A multi-objective problem is formulated with respect to voltage harmonic distortion, voltage profile of a system and total investment cost which includes installation and

incremental costs, where the voltage limits, and D-STATCOM capacity limits are considered as constraints of the control variables. The performance of the proposed method is assessed on the radial IEEE 16-bus test system using Matlab programming.

II. MULTI-OBJECTIVE PROBLEM FORMULATION

The purpose of determining optimal D-STATCOM placement is to improve power quality of a system by minimizing the total installation cost. Therefore, a multi-objective optimization problem is formed where its objective function includes three sub functions and three constraints to the control variables as described in following subsections.

Objective Functions

Minimization of average voltage deviation:

The voltage deviation index is defined as the deviation of the voltage magnitudes of buses i from unity as,

$$V_{dev-i} = \left(\frac{V_{i-ref} - V_i}{V_{i-ref}} \right)^2 \quad (1)$$

where V_{dev-i} and V_i are the reference and actual voltages at bus i , respectively. Therefore, using the summation of normalized V_{dev-i} for all buses, the average voltage deviation in the system in per unit (p.u.) can be expressed as

$$V_{dev-avr} = \frac{\sum_{i=1}^M V_{dev-i}^{norm}}{M} \quad (2)$$

Where M is the total number of system buses.

Minimization of average THDv:

To control the THDV level of the whole system, the average of the normalized THDV in the system buses is considered as

$$THD_{V-avr} = \frac{\sum_{i=1}^M THD_{V-i}^{norm}}{M} \quad (3)$$

Where THD_{V-i}^{norm} is the normalized THDv in bus i.

Minimization of the total cost of D-STATCOM:

The normalized total cost of a D-STATCOM, which is composed of the installation and incremental costs can be expressed as

$$C_{stat} = \frac{\sum_{i=1}^k \alpha S_{stat-i}^2 - \beta S_{stat-i} + C_{0-i}}{Cost_{max}} \quad (4)$$

Where C_{stat} , C_0 and S_{stat} are the normalized total cost, fixed installation cost and operating range of the D-STATCOM, respectively. In addition, α and β are fixed coefficients, which are assumed in this work as 0.0002478 and 0.2261, respectively.

B. Operational Constraints

Bus voltage limits:

Due to effect of D-STATCOM installation on system bus voltages, each bus voltage V_i must be maintained around a permissible voltage band as,

$$V_{i-min} \leq V_i \leq V_{i-max} \quad (5)$$

Where V_i is the voltage at bus i

D-STATCOM capacity limits:

Considering that the D-STATCOM capacity is inherently limited by the energy resources at any given location, the capacity S_{stat} has to be constrained within a permissible band as,

$$S_{APC-min} \leq S_{APC} \leq S_{APC-max} \quad (6)$$

C. Overall objective function

The overall optimal D-STATCOM placement problem can be configured as a constrained multi-objective optimization problem. Therefore, the weighted sum method is considered to combine the individual objective functions in terms of a single objective function. In addition, each constraint violation is incorporated in the overall objective function using the penalty function approach. Therefore, the final objective function to be minimized is expressed as

$$\begin{aligned} F &= f(\text{Location}, \text{Size}) \\ &= w_1 \frac{\sum_{i=1}^M V_{V-i}^{norm}}{M} + w_2 \frac{\sum_{i=1}^M THD_{V-i}^{norm}}{M} + w_3 C_{stat} \\ &+ \lambda_v \sum_{i \in M} [\max(V_i - V_{i-max}, 0) \\ &\quad + \max(V_{i-min} - V_i, 0)] \\ &+ \lambda_{APC} \sum_{i \in M} [\max(S_{stat} - S_{stat-max}, 0) \\ &\quad + \max(S_{stat-min} - S_{APC}, 0)] \end{aligned} \quad (7)$$

Where w_i and λ are the relative fixed weight factors assigned to the individual objectives and the penalty multipliers for violated constraints, which are large fixed scalar numbers. P, and M are the total D-STATCOM number, and total bus number, respectively.

The weight factors should be assigned to the individual objective functions based on their importance and may vary according to the desired preferences of the

power system operators. In this paper, the proper weighting factors used are $w_1 = w_2 = 0.4$ and $w_3 = 0.2$, in which the first two objectives are assumed to be equally more important.

III. FIREFLY ALGORITHM AND ITS APPLICATION IN D-STATCOM PLACEMENT

A. Standard Firefly Algorithm

Firefly algorithm (FA) is a novel nature-inspired metaheuristic algorithm that solves the continuous multi-objective optimization problems based on the social behaviour of fireflies [5]. The firefly algorithm is a metaheuristic algorithm, which is inspired by the flashing behaviour used by fireflies to attract each other in the mating process. The brightness of the firefly is the key point of the algorithm, and is equivalent to the objective function under consideration. Three main assumptions were made when proposing the algorithm:

- i) All fireflies are unisexual that is one firefly will be attracted by all others.
- ii) Attraction is dependent on the amount of brightness, that is a less brighter firefly is attracted to a brighter one.
- iii) The brightness of the firefly is equivalent to the objective function.

The attractiveness is dependent on the distance between the two fireflies as the intensity of light decreases as the distance between the two fireflies' increases. Therefore, the closer the fireflies the more attractive they seem to each other. Multiple variants of firefly algorithm are being developed. The firefly algorithm has been proved to be efficient at solving optimization tasks and can be more efficient than other meta-heuristic algorithms when applied to continuous constrained optimization tasks, stochastic functions, multi-modal functions and even in the field of digital image processing. Given the wide range of applications, less complexity and more efficiency than other meta-heuristic make the firefly algorithm a good subject for continuing research.

Flashing behaviour of the fireflies is unique to the kind of species they belong to and varies from one type of species to the other. The aim of such flashing behaviour can be either of attracting mates or for attracting prey. The flashing light can be formulated to mimic the objective function under consideration and formulate a new optimization algorithm.

The optimization process depends on the brightness of the fireflies and the movement of fireflies towards their brighter counterparts. Every firefly is attracted to the other depending on brightness because the fireflies are all unisexual according to the first assumption about artificial fireflies.

It is proven to be a very efficient technique to search for the Pareto optimal set with superior success rates and efficiency compared with the PSO and GA for both continuous and discrete problems [6]. In FA, two important issues arise, namely, the variation in light

intensity I and the formulation of the attractiveness β . In the simplest form and considering a fixed light absorption coefficient γ , light intensity I , which varies with distance r , can be expressed as

$$I(r) = I_0 \exp(-\gamma r^2) \quad (8)$$

Where I_0 is the light intensity at $r = 0$.

Consider the firefly's attractiveness as proportional to the light intensity seen by adjacent fireflies, the attractiveness β can be expressed as

$$\beta(r) = \beta_0 \exp(-\gamma r^2) \quad (9)$$

Where β_0 is the attractiveness at $r=0$

The distance between any two fireflies i and j at x_i and x_j , respectively, can be calculated using the Euclidean distance as,

$$r_{ij} = |x_i - x_j| = \sqrt{\sum_{d \in D} (x_{i,d} - x_{j,d})^2} \quad (10)$$

Where x_i, d is the d -th component of the spatial coordinate x_i of the i -th firefly and D is the dimension of the problem.

Therefore, the movement of firefly i to another more attractive (brighter) firefly j can be expressed as

$$x_i^{k+1} = x_i^k + \beta_0 e^{-\gamma r_{ij}^k} (x_j^k - x_i^k) + \alpha \xi_i \quad (11)$$

Where α is the randomization parameter and ξ_i is a vector of random numbers with Gaussian or uniform distributions.

During the iterative process, the brightness of one firefly is compared with the others in the swarm and the difference in the brightness triggers the movement. The distance travelled depends on the attractiveness between the fireflies. During the iterative process the best solution thus far is continuously updated and the process goes on until certain stopping conditions are satisfied. After the iterative process comes to a halt the best solution of the evaluation is determined and the post process is initiated to obtain the results.

B. Application of FA in Solving the Optimal Location and Sizing of D-STATCOM

In order to solve the optimal location and size of the DSTATCOM problem in radial distribution systems, FA is applied to minimize the objective function (7). Initially, the number of D-STATCOMs and the system specifications, including the bus and line data, should be considered as inputs of the FA. The number of D-STATCOMs can be chosen as any integer number between 1 and the maximum number of system buses.

The variables for optimization are the location of the DSTATCOMs and the real and imaginary D-STATCOM powers at the fundamental and harmonic frequencies. After initializing the locations and sizes of the D-STATCOMs in terms of the firefly populations, as shown in Fig. 1, the bus voltages in the fundamental and harmonic frequencies should be obtained using load-flow calculation. The voltage variations and THDV of each bus can be calculated using the computed bus voltages to calculate the objective function (7). Hence, the fireflies can be ranked to determine the current global solution, and

FA proceeds for the next iteration. The convergence criteria are set to $t = \text{MaxGeneration}$ or when the current global solution does not change for a specific number of iterations. Fig. 1 shows the schematic diagram of the procedures used in solving the optimal D-STATCOM placement and sizing problem using the FA. hardcopy, as shown in Fig. 1.

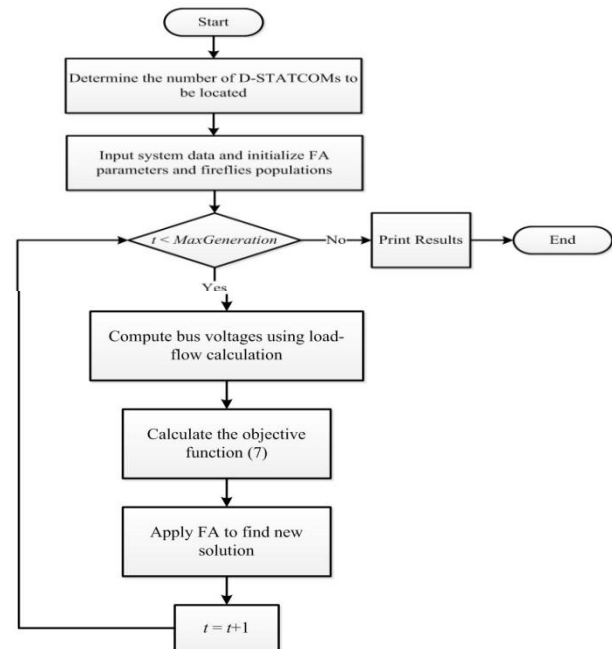

Fig1.FA implementation to solve the D-STATCOM placement and sizing problem

IV. SIMULATION AND RESULTS

In order to solve the problem of the FA in optimal placement and sizing D-STATCOM, the proposed method is applied on the modified IEEE 16-bus test system shown in Fig. 2 [8]. The system is balanced and composed of several linear and non-linear loads with a total power of 2.73 MVA. In addition to the non-linear loads, which distort the voltage and current waveforms of the system, a heavy induction motor is installed in bus 15, which creates voltage variation and voltage sag problems in the system.

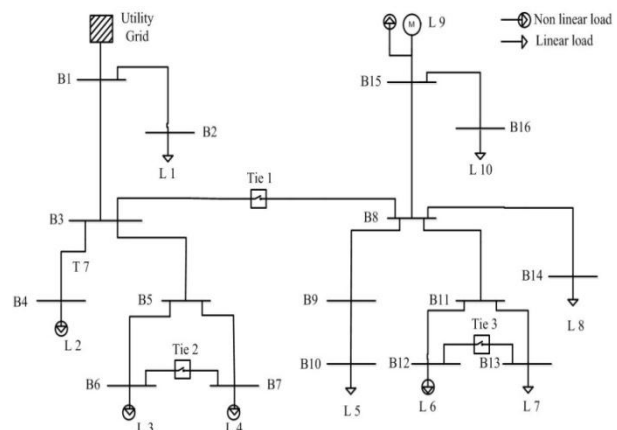

Fig.2. Single line diagram of the IEEE 16-bus test system

To solve the optimal D-STATCOM placement and sizing problem and improve the general power quality of the system, four D-STATCOMs with power rating limits of [0 1.5] p.u. are considered for placement, and minimum and maximum voltage limits are considered as 0.95 and 1.05 p.u., respectively. The objectives are to mitigate the harmonic distortion and to improve the voltage profile of the system using the proposed FA method. Table 1 shows the optimization results for the 16-bus test system, using the different optimization methods.

TABLE I: OPTIMIZATION RESULTS OF THE 16-BUS TEST SYSTEM

Solver	Location (Bus)	Rating(p.u.)	F	Cost(US\$)
FA	15	0.917	0.3016	2,733,281

From the results shown in Table I, the FA achieves the best performance in determining the optimal location and size of the D-STATCOMs by referring to the objective function, F values. To investigate the sensitivity of the

	SD (%)	Mean	Fmax	Fmin
FA	5.99	0.2993	0.3028	0.2972

proposed method to the randomness of the initial values, the standard deviation (SD) and the mean value are calculated for 20 run times of the FA with the optimization parameters being kept constant. Table II shows that SD and the mean values obtained from FA method.

TABLE II: SD AND MEAN VALUES AT DIFFERENT INITIAL VALUES

This result proves the higher accuracy and robustness of FA in solving the optimal placement and sizing problem of the D-STATCOM in the 16-bus distribution system. The convergence characteristic of the FA for the 16-bus system.

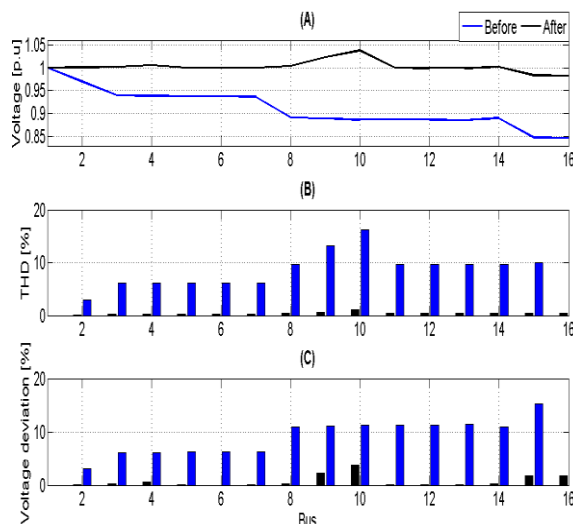

Fig.3. System performance before and after the D-STATCOM installation in the 16-bus test system; (A) Bus voltage, (B) Bus THD (C) Voltage deviation.

The voltage profile and THDV level of the 16-bus test system before and after the optimal D-STATCOM placement are recorded as shown in Table III. After the optimal D-STATCOM placement, the voltage profile of the system significantly improves, even when voltage sag with a depth of approximately 10% occurs as shown in Fig 3. In addition, the voltage harmonic distortion of all the system buses is also mitigated to meet the IEEE Std 519 requirements [10].

Table III: SYSTEM PERFORMANCE BEFORE AND AFTER D-STATCOM INSTALLATION IN THE 16-BUS TEST SYSTEM

Bus No	Bus voltage (p.u.)		THDV (%)		Voltage deviation (%)	
	Before	After	Before	After	Before	After
1	1.000	1.000	0.000	0.000	0.000	0.000
2	0.970	0.977	2.969	0.117	3.028	0.001
3	0.940	1.000	6.128	0.135	6.029	0.407
4	0.939	0.995	6.157	0.107	6.141	0.353
5	0.938	0.988	6.139	0.486	6.200	0.281
6	0.938	1.000	6.142	0.472	6.237	0.437
7	0.937	0.998	6.144	0.446	6.270	0.429
8	0.891	0.982	9.598	0.017	10.94	1.032
9	0.889	0.981	13.18	0.150	11.10	1.078
10	0.887	0.986	16.25	0.171	11.30	1.248
11	0.887	0.986	9.633	0.107	11.26	1.248
12	0.887	0.979	9.641	0.492	11.33	1.088
13	0.886	0.994	9.646	0.153	11.37	1.486
14	0.890	0.989	9.605	0.352	11.00	1.225
15	0.848	0.996	10.06	0.226	15.24	3.029
16	0.847	0.996	10.05	0.471	15.32	3.111

IV.CONCLUSION

This paper has presented an improved method to determine the optimal location and size of D-STATCOM in distribution systems. The method applied FA to solve the problem using a multi-objective function, defined to enhance the voltage profile of the system and to minimize the THDV and the total investment cost. The performance of the FA was analysed on the radial IEEE 16-bus test system using the Matlab software. The results proved that the proposed FA is able to determine the most effective

location and optimal size of the D-STATCOM in radial distribution systems.

ACKNOWLEDGEMENT

The authors would like to thank EEE Department of Acharya Insitiute of Technology for their support and encouragement, special thanks to Head of Department, **Prof. R.Vivekanada** and my guide **Padmaja K** for giving necessary inputs in this project.

REFERENCES

- [1] M. Farhoodnea, A. Mohamed, H. Shareef, and H. Zayandehroodi, "A Comprehensive Review of Optimization Techniques Applied for Placement and Sizing of Custom Power Devices in Distribution Networks," PRZEGLĄD ELEKTROTECHNICZNY (Electrical Review), vol. 88, pp. 261-265, 2012.
- [2] C. S. Chang and Y. Zhemmin, "Distributed mitigation of voltage sag by optimal placement of series compensation devices based on stochastic assessment," IEEE Transactions on Power Systems vol. 19, pp. 788795, 2004.
- [3] Y. Zhang and J. V. Milanovic, "Global Voltage Sag Mitigation With FACTS-Based Devices," IEEE Transactions on Power Delivery vol. 25, pp. 2842-2850, 2010.
- [4] N. Salman, A. Mohamed, and H. Shareef, "Reliability Improvement in Distribution Systems by Optimal Placement of DSTATCOM Using Binary Gravitational Search Algorithm," PRZEGLĄD ELEKTROTECHNICZNY, vol. 88, pp. 295-299, 2012.
- [5] S. Chandrashekhara Reddy and P. Prasad, "Power Quality Improvement of Distribution System by Optimal Placement of Distributed Generators Using GA and NN," in Proceedings of the International Conference on Soft Computing for Problem Solving (SocProS 2011) December 20-22, 2011, 2012, pp. 257-267.
- [6] X.-S. Yang, "Firefly Algorithm," in Engineering Optimization, ed: John Wiley & Sons, Inc., 2010, pp. 221-230.
- [7] G. Jati, "Evolutionary discrete firefly algorithm for travelling salesman problem," Adaptive and Intelligent Systems, vol. 6943, pp. 393-403, 2011.
- [8] M. Farhoodnea, A. Mohamed, H. Shareef, and H. Zayandehroodi, "Power Quality Analysis of Grid-Connected Photovoltaic Systems in Distribution Networks," Przegląd Elektrotechniczny (Electrical Review), vol. In press, 2013.
- [9] M. Farhoodnea, A. Mohamed, and H. Shareef, Harmonic Source Localization in Power Systems: Single and Multiple Harmonic Sources, : LAP LAMBERT Academic Publishing, 2011.
- [10] S. M. Halpin, "Revisions to IEEE Standard 519-1992," in IEEE PES Transmission and Distribution Conference and Exhibition, , 2006, pp. 1149-1151.