

Design & Development of Optical Frequency Division Multiplexing System for Digital Broadcasting Standard

Sapna Sadyan¹, Er. Paras Chawla²

Electronics & Communication Engineering Department, JMIT Radaur^{1,2}

Abstract: This work is concerned with how well OFDM performs in digital broadcasting when transmitted over an Additive White Gaussian Noise (AWGN) channel only. The main objective of this work is to design an OFDM system for digital broadcasting standard. In this, it uses 2k mode and 8k mode system. The main problem in OFDM is PAPR value. So, in this work, it also improves the value of PAPR under different modulation formats. The DVB-T system for terrestrial broadcasting is probably the most complex DVB delivery system. It is proven a worldwide success. It has become the de facto world standard for transmitting digital terrestrial television. Originally, the DVB-T standard was created for fixed and portable reception as the main application areas. OFDM can provide large data rates with sufficient robustness to radio channel impairments. In this, different modulation formats are used like QAM, QPSK etc. and their performance with these formats are evaluated.

Keywords: OFDM System, Digital Broadcasting, QAM modulation, DVB etc.

I. INTRODUCTION

Optical orthogonal-frequency-division multiplexing (OFDM) has shown its great potential in both long-haul and access optical networks [1]. Polarization division multiplexing coherent optical OFDM (PDM-CO-OFDM) has been experimentally demonstrated at Tb/s over long-haul transmission. OFDM has emerged as a leading modulation technique and in the optical domain. It is also used in wireless and wire-line applications and in almost every major communication standards.

The use of OFDM in optical communications mitigates transmission impairments and, at the same time, provides high-data rate transmission across dispersive optical media. The progress in Digital Signal Processing (DSP) technology can make processing at optical data rates feasible. O-OFDM introduces spectral efficiency and tolerance to impairments such as chromatic dispersion (CD) and polarization mode dispersion (PMD) to the system. It belongs to a broader class of Multi-Carrier Modulation (MCM) in which data information is carried over many lower rate subcarriers. The subcarriers are orthogonal to each other, and their spectra can overlap. This results in a very high spectral efficiency.

The insertion of a Cyclic Prefix (CP) makes OFDM an effective solution to Inter-Symbol Interference (ISI) and Inter-Carrier Interference (ICI), caused by a dispersive channel that can degrade the performance of the system. This CP consists of an identical copy of the first samples of the frame that are added at the end of it, implying an increase of the signal bandwidth. The signal processing in the OFDM transmitter/receiver is based on the FFT to implement the OFDM modulation/demodulation. So the symbols can be generated in a very computationally efficient way. Other transforms are also suitable to generate the OFDM symbols. This is the case of the Fast

Hartley Transform (FHT) that has recently been introduced in Intensity-Modulation (IM)/Direct-Detection (DD) systems because a simpler transmission system can be achieved with real processing [2].

The first proposal to use OFDM for transmission appeared in 1966 and was introduced by Robert W. Chang [10]. This document presents the way to implement OFDM and also explains its main concept. OFDM symbols are created by filtering the signal and then multiplying the outputs by different frequencies. Thus, the subcarriers are orthogonally created, they overlap between each other and they are band-limited. Therefore, the spectra are produced without causing ICI and ISI. This method supposed a huge revolution in the communication world and in 1969 appeared the Discrete Fourier Transform (DFT) as a way to generate the orthogonal subcarriers [2].

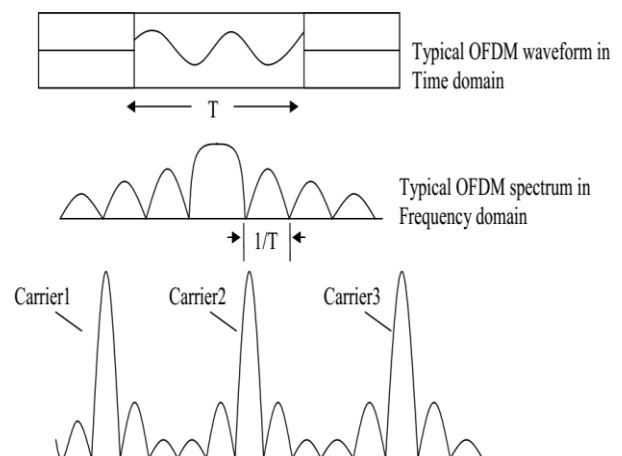

Figure 1: A Single Carrier of OFDM [1]

In 1995 Telatar and Foschini studied OFDM, for multiple antenna systems opening a new investigation area. OFDM

also began to be considered in wireless communications after the publication of Cimini of Bell labs in 1985. While in 1987 Lassalle and Alard proposed OFDM for digital broadcasting for mobile receivers. This article explains the benefits of using OFDM to overcome the adverse effects of severe multi-path propagation. Cioffi and others at Stanford demonstrated in 1990 the potential to apply OFDM in wire line communications [16], designing a Discrete Multi Tone (DMT) transceiver for High-Bit-Rate Digital Subscriber Line (HDSL). So with the advancement of powerful silicon DSP technology, OFDM triumphed in a broad range of applications such as the RF domain from digital audio/video broadcasting (DAB/DVB) to wireless local area networks (LANs). OFDM has been recently applied to optical communications. In 2001 appeared the first paper based on OFDM for optical wireless and in 2005 it was used in optical fiber communication systems [5].

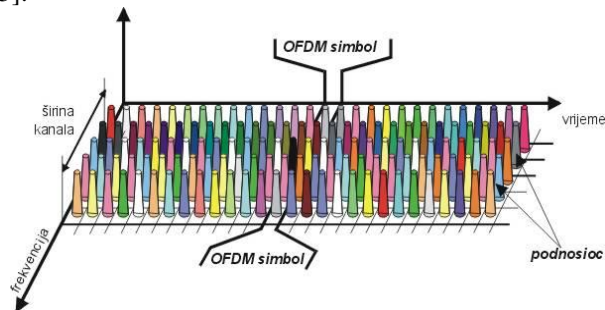

Figure 2: OFDM Pattern [2]

The paper is ordered as follows. In section II, it represents related work with proposed system in OFDM System. In Section III, It defines basics of OFDM technique. In Section IV, It defines proposed OFDM System. Finally, conclusion is explained in Section V.

II. THE DVB-PROJECT AND STANDARDIZATION

The DVB Project was created to unify and to agree all the specifications for digital media, including broadcasting. It is compose by around 300 companies. Although the digital technology started to appear at the beginning of the 80's, until 1990 was impossible to bring digital television broadcasting to home due the higher investment that was needed and made it impractical to implement. Many companies as equipment, broadcasters, decided to unify efforts during 1991 to develop terrestrial TV. It gave as a result the formation of a group for the development of digital television in Europe.

This formation was called European Launching Group (ELG) and tried to include the maximum European media interest groups, public and private, and the consumer electronics manufacturers. All the rules that were adopted by this collective and the actions that they wanted to take to expand digital TV were established in a memorandum of understanding (MoU) and it was a document describing the agreement between parts. The MoU was signed by all ELG in 1993 indicating an intended common line of action. At this moment, the Launching Group renamed itself as the Digital Video Broadcasting Project (DVB). The development work in

digital television started to gear up to reach the main objective: bring digital TV to home in whole Europe [6].

The objective of the DVB Project were to develop digital satellite, cable, and terrestrial broadcasting technologies and promote and standardization of these. The first step was that the system would contain a combination of image, audio or multimedia. This work resulted in ETSI standards for the physical layers, error correction and transport for each delivery medium. The DVB Project delivery platforms and open standards when they are available. From the first moment, the standards have been common for all the companies and only when there would be no choice there can be differences.

A. DVB-Project: The Emergence of the Standards

The DVB Project has used to promote standards and the transport for all systems is the MPEG2 transport stream. The standards are identifying with the initials which identify the area. For example DVB-S is the specification for the first generation version of the digital satellite system and DVB-S2 for the second generation version of the DVB digital satellite system. At the beginning of the 1990s, due to the change that was happening in Europe and market priorities, the group decided to develop satellite and cable standards before terrestrial because they could develop more rapidly than terrestrial systems.

The DVB-S (digital satellite broadcasting) was developed in 1993. This system was created using QPSK and it introduces channel coding and error protection, that are described at the specification. The first operator that offers these broadcast services in Europe was in 1995 by pay operator Canalplus in France.

The DVB-C standard (system for digital cable networks) was established in 1994. It is centred on the use of 64 QAM. The DVB-T system (digital terrestrial television) was more difficult to develop because of the noise introduced by the environment and the bandwidth needed and the losses introduced by the multi-path. The system required to adapt its decoding depending of the signal. The key element is the use of OFDM. It can works in two modes:

- 2K carriers + QAM modulation: adequate when the receiver is in movement (take into account Doppler effect)
- 8K carriers+ QAM: this mode allows more multi-path protection.

B. Basic Standards on Digital TV

The digital TV is transmitted by satellite, cable or terrestrial transmitters. Each one has their own standard that makes possible the transmission and the reception depending of the stage. In the figure shown below is possible to see the use of these three basic systems.

1. Digital Video Broadcasting by Satellite (DVB-S)

The system DVB-S (Digital Video Broadcasting by Satellite) allows an spectacular increase of the transmission's capacity for digital television programs by

satellite using the compression video techniques based on the standard MPEG-2 for the source coding and the multiplexor. The only variation between this standard and the others proposed by the DVB (cable and terrestrial broadcast), is the type of modulation and the channel code used. For transmissions by satellite is taken the QPSK (Quadrature Phase Shift Keying) code, with a variable binary flow between 18,4 to 48,4 Mbps.

2. Digital Video Broadcasting by Cable (DVB-C)

The DVB-C system is based in the European Standard ETS 300 429 created in 1994 “Digital Broadcasting Systems for Television, Sound and Data services; Framing structure, Channel coding and Modulation for Cable systems”. It is valid for any cable network defines the modulation of the packages by MPEG-2 by cable.. The characteristics of this standard are the good signal-to-noise ratio, the small space available in frequencies that can be used, the rebounds and the non-linear distortion. This standard works with different types of modulation: QAM, 16-QAM, 32-QAM, 64-QAM, 128-QAM or 256-QAM. The most often is 64-QAM and the FEC is exactly the same as the DVB-S.

III. DESCRIPTION OF PROPOSED SYSTEM

Orthogonal frequency division multiplexing (OFDM) is a modulation technique which belongs to a broader class of multicarrier modulation (MCM) in which the data information is carried over many lower rate subcarriers. Two of the fundamental advantages of OFDM are its robustness against channel dispersion and its ease of phase and channel estimation in a time-varying environment. OFDM is now used in most new and emerging broadband wired and wireless communication systems because it is an effective solution to inter-symbol interference caused by a dispersive channel.

The digital TV system called DVB-T (Terrestrial Digital Video Broadcasting), specified in the ETSI standard (European Telecommunications Institute Standards) EN300 744. This system is designed to allow optimum use of the available frequency spectrum with a structure of broadcast data enough to accommodate numerous services: multiplex of up to 8 video programs in a 8 MHz bandwidth (where only one analog program was broadcasting), multi-language stereo/surround channels, etc.

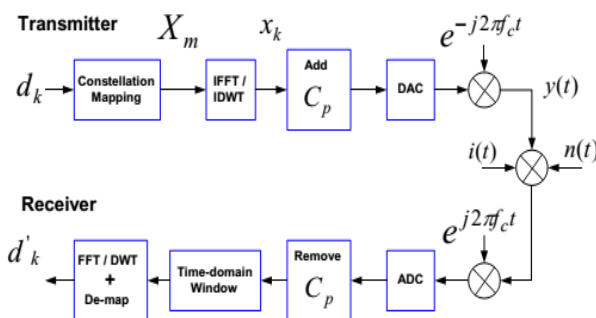

Figure 3: OFDM Transmission & Reception [3]

The development of OFDM system can be divided into three stages, these are – Frequency division multiplexing, multicarrier communication and orthogonal frequency division multiplexing. The OFDM system can be divided into three parts mainly, transmitter, channel and receiver. The OFDM transmitter works as: The input serial data stream is first converted into many parallel data streams after passing through a serial – to – parallel converter. These parallel data streams are modulated onto the orthogonal subcarriers and changed to the time domain OFDM symbol by applying the IFFT. The OFDM signal is then converted to analog signal by applying the digital-to-analog conversion (DAC) and filtered with low pass filter.

The baseband signal thus obtained can be up converted to an appropriate RF. At the receiver, the received signal is first down converted, sampled with an ADC and then the complex form OFDM signal is demodulated by applying the FFT. The demodulated signals go through a symbol decision module. Finally, the multiple data channels are converted back to a single data stream by applying the parallel – to – serial data converter.

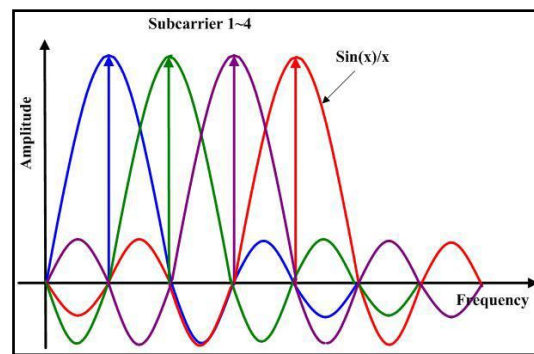

Figure 4: OFDM Spectrum in Frequency Domain [12]

The first step in the transmitter is generating theMPEG-2 transport packets. In the simulations random data have been used. By this we skip the step of randomizing the data with a scrambler. After the packets are generated they have to be adapted to the channel characteristics of the DVB-T standard. First, we convert the random bits into modulated symbols, with one of the following signal constellations: QPSK, 16-QAM, 64-QAM.

The input data stream is formatted into the word size required for transmission in each OFDM symbol. For example, for a subcarrier modulation of 4-QAM, each subcarrier carries 2 bits of data, 16-QAM has 4 bits and 64-QAM has 6 bits of data. So for a transmission using 6817 subcarriers using 4-QAM, the number of parallel symbols entering the IFFT block is 4096. The modulation scheme is a mapping of data words to a real (In phase) and imaginary (Quadrature) constellation, also known as an IQ constellation. For example, 64-QAM involves 6 bits in each symbol (data word). Each data word is mapped to one unique IQ location in the constellation. A large number of modulation schemes are available allowing the number of bits transmitted per subcarrier per symbol to be varied. In the receiver, the received IQ symbol de-mapped back to data words. This is called Demodulation.

The codification of the signal adds enough redundancy and protection to permit the correction of errors and to make the signal more robust. The Forward Error Correction (FEC) is used after the signal pass through the channel. This codification allows to retrieve the information transported by subcarriers that are cancelled due to the selective fading of the radio channel.

At the transmitter of an OFDM system, data are apportioned in the frequency domain and an IFFT is used to modulate the data into the time domain. The FFT output data are guaranteed to be real-valued if conjugate symmetry is imposed on the input data. In the receiver, an FFT is used to recover the original data. The FFT allows an efficient implementation of modulation of data onto multiple carriers [11]. Due to the similarity between the forward and inverse transform, the same circuitry, with trivial modifications, can be used for both modulation and demodulation in a transceiver. A fundamental challenge with OFDM is that a large number of subcarriers are needed so that the transmission channel affects each subcarrier as a flat channel. This leads to an extremely complex architecture involving many oscillators and filters at both transmit and receive ends.

To reduce the effects owing to the radio channel is used the Orthogonal Frequency Division Multiplexing (OFDM). This technique consists in a multi-carrier modulation where the signal is divided in N-flows of low speed that modules several sub-carriers. The duration of the low speed symbols are selected in a way that exceed the dispersion time including the last echo. Every sub-carrier that is modulated has a zero in its spectrum at the frequency of the following sub-carrier. In such a way, they are orthogonal. To obtain this, the frequencies of every sub-carrier have to be separated the same value as the inverse of the low speed symbols' duration.

Here, the OFDM subcarriers are generated in the digital domain using IFFT. The FFT-based O-OFDM transmitter is composed of a RF OFDM transmitter and a RF-to-optical up-converter, while the receiver is composed of an optical-to-RF down-converter, and a RF OFDM receiver.

Advantages of OFDM

There are many advantages of OFDM. Some of these are –

- OFDM divides the high-speed data stream into multiple low-data-rate subcarriers and then transmit them, thereby increasing the symbol duration and reducing the ISI, thus making OFDM, a good candidate for future high-speed communication systems.
- Smooth upgrading from low-speed transmission to high-speed transmission is possible in OFDM without major changes in system design.
- OFDM gives high spectrum efficiency and capacity.
- Energy-efficient operation is possible with OFDM through adaptive modulation and dynamically switching on/off specific subcarriers according to customer bandwidth requirements and channel conditions.

Performance Parameters: PAPR (Peak to Average Power Ratio)

An OFDM consists of a number of independently modulated subcarriers, which can give a large PAPR value when added up coherently. Large PAPR means large amplifier back-offs, which reduces power efficiency of RF amplifier and also increase the complexity of converters.

IV. RESULTS

The first task to consider is that the OFDM spectrum is centred on f_c ; i.e., subcarrier 1 is 7.612 MHz to the left of the carrier and subcarrier 1,705 is 7.61 2 MHz to the right. One simple way to achieve the centring is to use a 2N-IFFT [2] and T/2 as the elementary period. The figure 4.3 shows the proposed GUI of 2k mode of DVB system using OFDM. The elementary time period for a base band signal is taken as T.

Table 1: OFDM Parameters for 2k and 8k Mode

Parameters	2k Mode	8k Mode
OFDM Symbol Period (Tu)	224e-6	896e-6
Baseband elementary period (Tb)	Tu/2048	Tu/2048
Number of carriers (K)	1705	6817
FFT/IFFT Length	4096	4096

Here we consider a simple integer relation $RS=40/T$. This integer relation gives us a frequency close to 90 MHz. Now we design the transmitter, and for that the steps undertaken have been shown. At first we add 4,096-1,705=2,391 zeros to the signal info at (A) to achieve over-sampling, and to centre the spectrum. In Fig. below, we observe the result of this operation and that the signal “carriers” uses T/2 as its time period. We can also notice that “carriers” is a discrete time baseband signal. The first step is to produce a continuous-time signal and to apply a filter $g(t)$, to the complex signal “carriers”. The impulse response, or pulse shape, of $g(t)$ is shown.

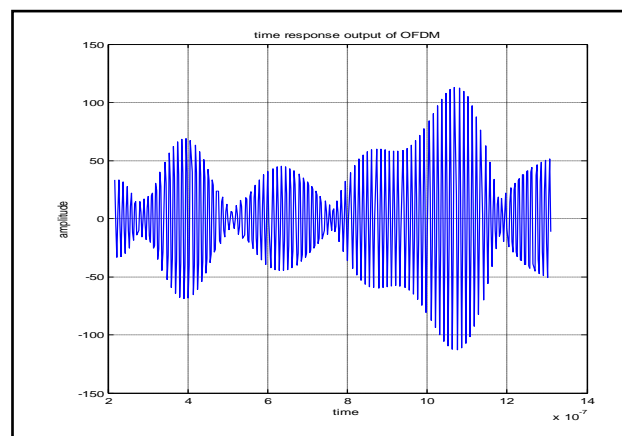

Figure 5: OFDM Output of 2 K DVB Systems

The first thing to notice is the delay of approximately 2×10^{-7} produced by the filtering process. Aside of this delay, the filtering performs as expected since we are left with only the baseband spectrum. We must recall that

subcarriers 853 to 1,705 are located at the right of 0 Hz, and subcarriers 1 to 852 are to the left of $4fc$ Hz.

This ratio of the peak to average power value is termed as Peak-to-Average Power Ratio.

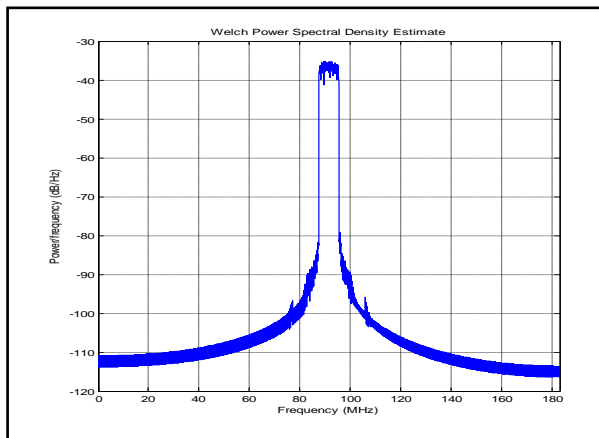

Figure 6: OFDM Power Spectra Using 2 K Modes

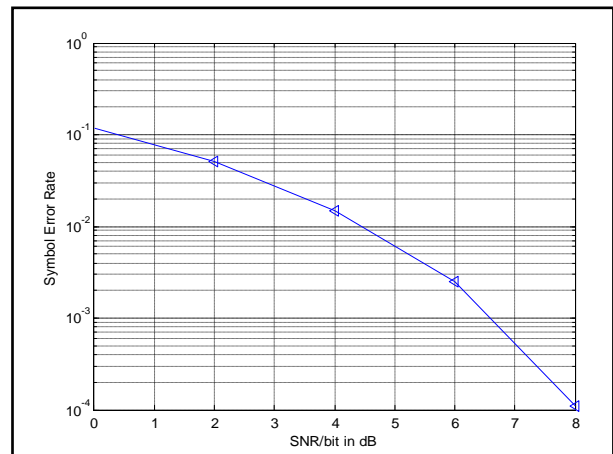

Figure 9: SER Output of 2k Mode

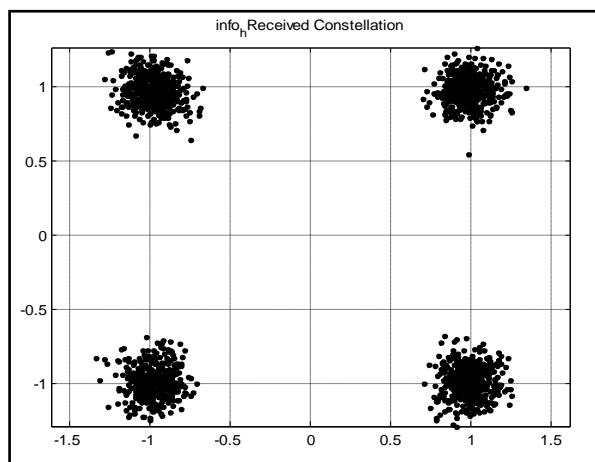

Figure 7: Received 4 QAM Constellation Plot

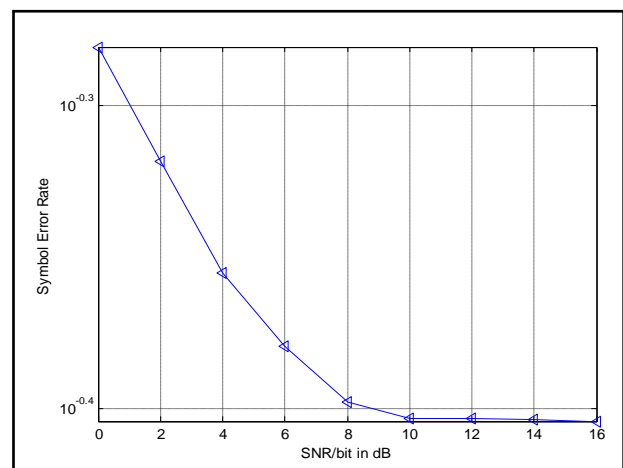

Figure 10: SER Output of 8k Mode

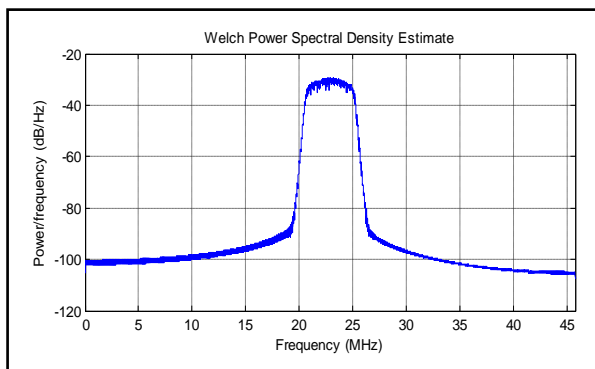

Figure 8: OFDM Power Spectra Using 8 K Modes

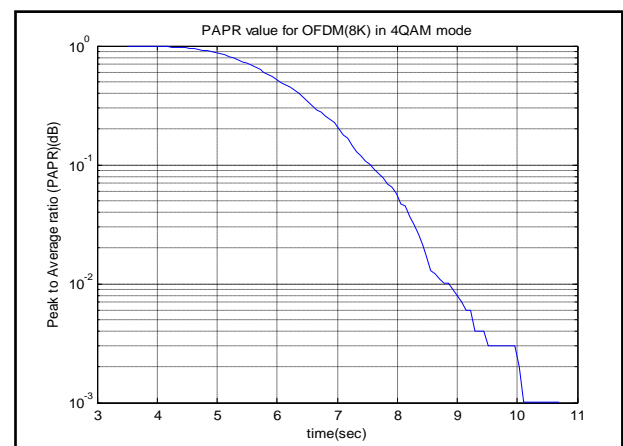

Figure 11: PAPR Output of Proposed System

OFDM is a very attractive technique for multicarrier transmission and has become one of the standard choices for high – speed data transmission over a communication channel. It has various advantages; but also has one major drawback: it has a very high PAPR. PAPR is generally used to characterize the envelope fluctuation of the OFDM signal and it is defined as the ratio of the maximum instantaneous power to its average power. Presence of large number of independently modulated sub-carriers in an OFDM system the peak value of the system can be very high as compared to the average of the whole system.

Table 2: PAPR Comparison of Proposed System

Parameter	QPSK	4-QAM	16-QAM	64-QAM
PAPR	6.123	6.18	6.153	6.06

V. CONCLUSION

The main objective of this work is to design an OFDM system for digital broadcasting standard. In this, it uses 2k mode and 8k mode system. OFDM is based on FFT based subcarriers. The main problem in OFDM is PAPR value. So, in this work, it also improves the value of PAPR under different modulation formats. The DVB-T system for terrestrial broadcasting is probably the most complex DVB delivery system. Originally, the DVB-T standard was created for fixed and portable reception. As expected it has proven a worldwide success. This whole work is based on the simulation results obtained from the simulation of signal using the 2K mode & 8k mode and the parameters specified for the same. After this, different modulation formats are also compared on the basis of performance parameters. The Additive White Gaussian Noise (AWGN) corrupted the transmitted signal and this resulted in a different received 4QAM constellation than the original constellation. For small SNR values the calculated error rate was quite large and ISI was produced due the relative high power of noise. As SNR was increased the error rate was decreasing.

REFERENCES

- [1] Bharath Umasankar, A. D. S. Jayalath, "Adaptive Performance Improvement of OFDM Radio over Fiber Systems", IEEE 2007.
- [2] Xingwen Yi, William Shieh, "Phase Noise Effects on High Spectral Efficiency Coherent Optical OFDM Transmission", IEEE Journal Of Lightwave Technology, Vol. 26, No. 10, May 15, 2008.
- [3] S.Jawla, R.K.Singh, "Different Modulation Formats Used In Optical Communication System" IOSR Journal of Electronics and Communication Engineering (IOSR-JECE), Vol. 8, Issue 4, 2013.
- [4] Sambaraju, Rakesh. "16-QAM Photonic Vector Modulator for Gigabit Wireless Links." IEEE Journal on Selected Areas in Communications, 2013
- [5] Liang Zhang, Xiaofeng Hu, Tao Wang, Qi Liu, Yikai Su," Proposal of A Star-16QAM System Based on Intersymbol Interference (ISI) Suppression and Coherent Detection" Proc. of SPIE, VOL. 7514 5140V-1, 2009
- [6] Abdulmir Ali, Werner Rosenkranz, and Jochen Leibrich, "Design considerations and performance comparison of high-order modulation formats using OFDM", IEEE 2012.
- [7] Guoying Zhang, Marc De Leenheer, Annalisa Morea, Biswanath Mukherjee, "A survey on OFDM-based electric core optical networking", IEEE 2013.
- [8] Sarangi Devasmitha Dissanayake, Jean Armstrong, "Comparison of ACO-OFDM, DCO-OFDM and ADO-OFDM in IM/DD systems", IEEE 2013.
- [9] Chin – Sean Sum, Fumihide Kojima, Hiroshi Harada, "Performance analysis of a multi-hop IEEE 802.15.4g OFDM system in multi-PHY layer network", IEEE 2013.
- [10] Ramon Casellas, Raul Munoz, Josep M. Fabrega, Michela Svaluto Moreolo, Ricardo Martinez, Lei Liu, Takehiro Tsuritani, Itsuro Morita, "Design and experimental validation of a GMPLS/PCE control plane for elastic CO-OFDM optical networks", IEEE 2013.
- [11] Xiang Li, Wen-De Zhang, Arokias Wami Alphones, Changyuan Yu, Zhaowen Xu, "Channel equalisation in optical OFDM systems using independent component analysis", IEEE 2014.
- [12] Gnauck A.H. et al., "Generation and transmission of 21.4-Gbaud PDM 64-QAM using a high-power DAC driving a single IQ modulator," Technical Digest of Optical Fiber Communication Conference, PDPB2, 2011.
- [13] Michela Svaluto Moreolo, "Performance Analysis of DHT-Based Optical OFDM Using Large-Size Constellations in AWGN", IEEE Communications Letters, Vol. 15, No. 5, May 2011.
- [14] M. M. Kamruzzaman, "Performance of Turbo coded wireless link for SISO- OFDM, SIMO-OFDM, MISO-OFDM and MIMO-OFDM system", IEEE 2011.
- [15] X. Q. Jin and J. M. Tang, "Experimental Investigations of Wavelength Spacing and Colorlessness of RSOA-Based ONUs in Real-Time Optical OFDMA PONs", IEEE Journal of Light wave Technology, Vol. 30, No. 16, August 15, 2012.
- [16] Wei-Chieh Huang, Chih-Peng Li, "Optimal Pilot Sequence Design for Channel Estimation in CDD-OFDM Systems", IEEE Transactions on Wireless Communications, Vol. 11, No. 11, November 2012.