

Portable Camera Based Information Reading of Hand Held Packaged Product for Blind Person

Nitin N. Gaurkar¹, Prof. P. M. Soni²

Student, Electronics and Telecommunication, Deogiri Institute of Engineering and Management studies,
Aurangabad, Maharashtra¹

Professor, Electronics and Telecommunication, Deogiri Institute of Engineering and Management studies,
Aurangabad, Maharashtra²

Abstract: It is very difficult to understand the content or material in packaged product for the blind persons. With the help of sensation and smelling blind person can identify the material like sugar, salt etc. but the contents or materials in packaged products are very difficult to understand so in this project we are dealing with this drawback and find out product information reading for blind person. To identify the information about the packaged product by using camera and the image taken from camera is given to mat lab for image processing. In mat lab the image of the product is compared with training dataset which was captured by camera and if the comparison of the captured image equals to the training dataset given to Bluetooth module of microcontroller and this is transferred to Bluetooth inbuilt android mobile. The corresponding information or application related to the tag is opened in the android mobile. The image and the text related to packaged products are displayed on android mobile device and also voice announcement of the same text will be announced from the related application installed in mobile device. So the user can hear the information of packaged product by connecting earphones to android mobile device.

Keywords: Portable Camera, Blind person, packaged products, mat lab, information reading, android mobile.

I. INTRODUCTION

With the survey of world health organization in 2014-15 285 million people are visually impaired worldwide from this 39 million are totally blind and 246 million have low vision. From this 90% of people having no income source and 82 % of blind person having aged is above 50. [1][2] In day to day life there is almost products which contain packaged like hand held package product, medicine bottles, etc. today, there are already a few systems which read the information or text on the product but in this most of system read only the text of the product. For example, portable bar code readers designed to help blind people identify. But in this promises blind person read only character on that product not the detailed information like why it used? Why it eating? Like that. So the project gives all information about that product, medicine bottles etc.

II. EXISTING SYSTEM

Today, there are already a few systems that have some promise for portable use, but they cannot handle product labelling.

A. Braille lippy bar code stickers which sticks on portable hand held packaged product but which is very expensive because of this every packaged product which you have to sticks Braille lippy code stickers and it not possible. [3]

B. Portable bar code readers designed to help blind people identify different products in an extensive product database can enable users who are blind to access information about these products through Speech and Braille. [4] But a big limitation is that it is very hard for blind users to find the position of the bar code and to correctly point the bar code reader at the bar code.

Some reading assistive systems such as pen scanners might be employed in these and similar situations. Such systems integrate OCR software to offer the function of scanning and recognition of text and some have integrated voice output.

However, these systems are generally designed for and perform best with document images with simple backgrounds, standard fonts, a small range of font sizes, and well-organized characters rather than commercial product boxes with multiple decorative patterns. Most state-of-the-art OCR software cannot directly handle scene images with complex backgrounds [7].

C. Pen Scanner for blind person but it having same drawback like optical character bar code reader i.e. blind person not exact pointing it have complication.[5]

D. A number of portable reading assistants have been designed specifically for the visually impaired “K-Reader Mobile” runs on a cell phone and allows the user to read mail, receipts, fliers, and many other documents. However, the document to be read must be nearly flat, placed on a clear, dark surface (i.e., a non-cluttered background), and contain mostly text. In addition, “K-Reader Mobile” accurately reads black print on a white background, but has problems recognizing colour text or text on a colour background. It cannot read text with complex backgrounds. Furthermore, these systems require a blind user to manually localize areas of interest and text regions on the objects in most cases. [5]

E. Portable Camera-Based Product Label Reading For Blind People is camera-based assistive text reading framework to help blind persons read text labels[8][9] and

product packaged from hand-held objects in their daily life but this system have limitation only read the text on the product not gives total information of that product. A number of portable reading assistants have been designed specifically for the visually impaired [10][11]

F. To Identify the objects by using camera and is given to mat lab for image processing in Mat lab images will be detected thereby after recognizing particular thing data is given to ARM 7 processor which is interfaced with speaker so that after identification is done the product name is given to blind person through voice but it have limited range.

III. PROPOSED SYSTEM

Here in project we modified with the existing system. In this we used LPC 2148 ARM based microcontroller which is interfacing with the LCD and MAX 232 IC and also instead of VOICE IC 9600 we used android application which used in android mobile. Because of this blind person can use this system at specific distance and read the information of packaged product.



Fig1. Top View of Proposed system

A. Proposed System Block Diagram

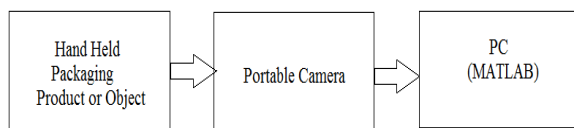

Fig2. Block Diagram of Transmitter Unit

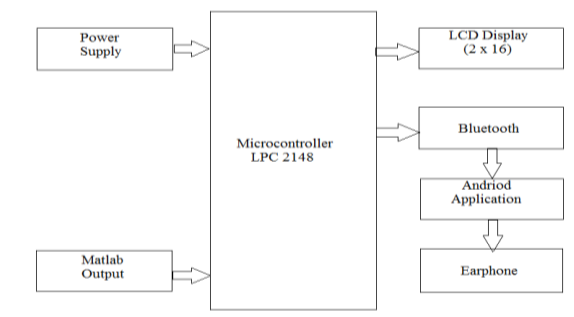

Fig3. Block Diagram of Receiver Unit

B. Transmitting Section.

The transmitting unit which contains three parts i.e. camera, packaged product and personal computer or laptop.

Initially in transmitting section the image of packaged product which is captured by camera with the help of computer or laptop that contains matlab software and that captured image called as “trained image” that trained image which is stored in the database of a laptop or PC.

C. Receiver Section.

In receiver section which contains power supply, Microcontroller kit Based on ARM LPC 2148, LCD, Android mobile device with application and earphone.

Again we captured same image of the packaged handheld product by using camera is considered as “test image” and by using mat lab we compared trained and test image. If both images are matched correctly which give voice announcement of handheld product information by using android application installed in android mobile device and also displays the product name on LCD which is interfacing with Microcontroller LPC 2148.

IV. ADVANTAGES

- a. It removes physical hardware requirement.
- b. It is less expensive and Portability.
- c. Accuracy and Flexibility.
- d. Automatic Voice detection.

V. APPLICATIONS

- a. It is very useful in blind person school.
- b. It is useful in pharmacy for blind person also for normal person

VI. CONCLUSION AND FUTURE WORK

The main aim of this project is to design a system for blind persons to recognize the hand held packaged objects or products .we design it with the help of microcontroller and android application and find products or objects information with voice announcements.

Our feature work we instead of Bluetooth we used the Wi-Fi because of this several users can connected and help to read the information of the product. Now our system is real time based. Means it gives 5 ms delay but we removed that delay it automatically captured the image. And also we used wireless camera.

REFERENCES

- [1] World Health Organization. (Aug 2015). 10 facts about blindness and visual impairment [Online]. Available: [http:// www.who.int /features/ fact files/ blindness/en/](http://www.who.int/features/fact_files/blindness/en/)
- [2] Visually impaired people [Online] [https://en.wikipedia.org/wiki/ Visual impairment](https://en.wikipedia.org/wiki/Visual_impairment)
- [3] Introduction to Braille language online Available: [Http://www. Lowvision.org/ introduction_to_braille.html](http://www.Lowvision.org/introduction_to_braille.html)
- [4] Scan Talker, Bar code scanning application to help Blind Identify over one million products. (2006) .[Online] .Available: [http:// www.freedomscientific.com/fs_news/PressRoom/en/2006/ ScanTalker2 - Announcement_3-30-2006 .asp](http://www.freedomscientific.com/fs_news/PressRoom/en/2006/ScanTalker2_-_Announcement_3-30-2006.asp)
- [5] Pen scanner for blind person online: [https://www. prv.se/en/patents /why-apply-for-a-patent /examples-of-patents/pen-with-scanner/](https://www.prv.se/en/patents/why-apply-for-a-patent/examples-of-patents/pen-with-scanner/)
- [6] KReader Mobile User Guide, knfb Reading Technology Inc. (2008). [Online].Available:<http://www.knfbReading.com>.
- [7] Ender tekin, davidvasquea, jamescoughlan “S-K smartphone bar code reader for blind person” HHS public assess at june 2014
- [8] C. Yi and Y. Tian, “Assistive text reading from complex background for blind persons,” in Proc. Int. Workshop Camera-Based Document Anal.Recognit., 2011, vol. LNCS-7139, pp. 15–28.
- [9] T. Phan, P. Shivakumara, and C. L.Tan, “ALaplacian method for video text detection,” in Proc. Int. Conf. Document Anal.Recognit., 2009, pp. 66–70.
- [10] The Portset Reader, TVI Technologies for the Visually Impaired Inc., Hauppauge, NY, USA. (2012). [Online].Available:[http:// www.tvi-web.com/products/portsetreader.html](http://www.tvi-web.com/products/portsetreader.html).

- [11] Kumar, R. Gupta, N. Khanna, S. Chaudhury, and S. D. Joshi, "Text extraction and document image segmentation using matched wavelets and MRF model," IEEE Trans Image Process., vol. 16, no. 8, pp. 2117–2128, Aug. 2007.

BIOGRAPHY



Nitin N. Gaurkar received B.E degree in Electronics and Telecommunication from Aditya college of Engineering in the year of May 2011. Now I perusing M.E in electronics and Telecommunication from Deogiri institute and Management studies, Aurangabad affiliated to Dr. Babasaheb Ambedkar University Aurangabad Maharashtra India. His research interests include in the field of Embedded Systems, Portable camera based product information reading for blind person.

Prof. P. M. SONI completed B.E in 1995 from College of Engineering; Buldhana also completed M.E in 2010 from Government College of Engineering, Aurangabad. She having 20 year of experience and now perusing lectureship in Deogiri institute of Management studies, Aurangabad.