

En Route Ambulance

Deepthi S¹, Irene Mathew², Irene Sara Jose³, Jacinta Jose⁴, R S Divya⁵

Department of ECE, Amal Jyothi College of Engineering, Kottayam, India^{1,2,3,4,5}

Abstract: Due to the enormous growth in the number of vehicles, traffic density in cities is increasing day by day. So when it comes to the case of an ambulance, the chances for it to get stuck in traffic blocks are very high. Such situations can even cause death if the victim is in a critical stage. The delay in reaching of the ambulance to the accident location and the traffic blocks in between accident location and hospital increases the chance of death of the victim. This calls for the need of introducing a system to reduce the loss of life due to the delay in reaching the hospital. Our project considers optimal transport routes of ambulances which minimize the transport duration to a hospital. PIC microcontroller, GPS, GSM, RF ID, ZIGBEE are the major components used. Our project is mainly concerned in that area where, when an ambulance approaches the traffic signal, it will be cleared automatically, that is the signal will turn green with respect to the arrival of the ambulance. Here we are using an RF ID for detecting the ambulance. The project mainly consists of two sections; an ambulance section and traffic section. GPS module is used to determine the current location of the ambulance. GSM is used for sending message to the hospital informing that the ambulance is on the way.

Keywords: Global Positioning System (GPS), Global System for Mobile Communication (GSM), Radio Frequency ID (RF ID), ZIGBEE, Traffic section, Ambulance section.

I. INTRODUCTION

In this 21st century, traffic congestion has become one of the major problems in cities and urban areas. This can lead to road accidents and loss of life. Currently there is no technology for optimal route detection. As it is done manually there is loss of life in golden hours. The accident victim is dependent on the mercy of others to rush him to hospital. Due to all these factors there is a high rate of mortality of the accident victims.

In addition to this there is delay in the ambulance reaching the hospital due to the traffic congestion which increases the chances of the death of victim.

Human life is greatly affected due to delay taken by the ambulance to reach the accident spot as well as the delay in reaching hospital. Chances are very high for it to get stuck in the traffic signal.

This situation can be avoided if the traffic signals in the path of the ambulance are GREEN (ON). There is the need for implementing a system by which the ambulance can arrive on time and reach hospital as fast as possible.

Here we introduce a system for controlling the traffic signals automatically. There would be control of traffic light signals in the path of the ambulance via RF communication to provide a clear path for the ambulance.

This will minimize the time required by the ambulance to reach the hospital. Along with this, the ambulance location is tracked continuously, and text message is sent to the hospital informing the current location of the vehicle.

For this the device is equipped with several General purpose transceivers, vehicle location module and GSM module. RF module, GPS and GSM unit fitted in the vehicle detects and sends the ambulance location to the corresponding hospital's contact number.

This system consists of two sections: ambulance section and traffic section. An RFID Tag is installed several meters away from the traffic post. When the ambulance crosses the tag, the arrival of the ambulance is detected and the traffic light turns GREEN.

This is done with the help of Radio Frequency Communication. GPS module in the ambulance tracks the location and sends it using GSM module to an already fed mobile number. The corresponding location is then shown in the Google map.

The main objectives of the project:

- 1) To switch the traffic signal based on the arrival of the ambulance.
- 2) To inform the hospital the location of ambulance using GPS and GSM technology.

Benefits of the project:

- 1) To give a clear way to emergency purpose vehicles on road.
- 2) They can reach their destination in least time without stopping at traffic intersection.
- 3) Potentially stress full situation are minimized.
- 4) Decreases the management cost.
- 5) To show the current location of the ambulance in the Google map.

II. SYSTEM ARCHITECTURE

The En route Ambulance System, hereby reported consists of essentially consists of two sections:

- Traffic Section
- Ambulance section.

A) Ambulance Section

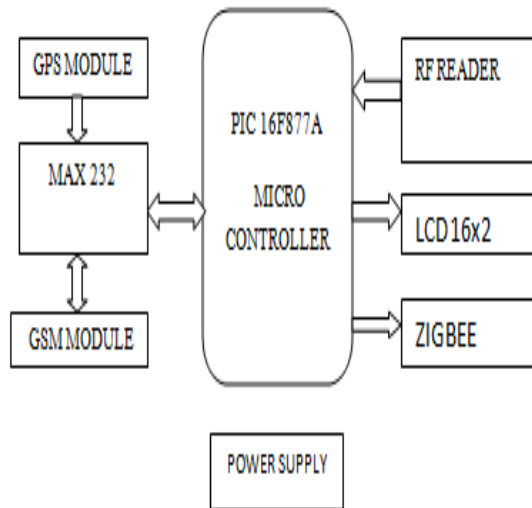

Fig.1. Block diagram of ambulance section

The tracking of the ambulance is done by using GSM, GPS and MAX232. MAX232 is an IC which converts signal from an RS232 serial port to signals that are suitable for the use in TTL compatible digital logic circuits. GPS Module in the Ambulance Section continuously receives signals from its satellites and delivers it to the PIC IC. The contact mobile number of the hospital is already programmed in the PIC Microcontroller. When a status signal is sent to the Microcontroller through GSM, it takes the current ambulance location from the GPS and messages it to the already programmed hospital mobile number. An application installed in this mobile phone processes the latitude and longitude, and displays the exact position in the Google map.

• Power Supply Circuit

The entire circuit is powered by a 5v input. So it is necessary to provide a constant invariable 5v supply to support the entire working of the system.

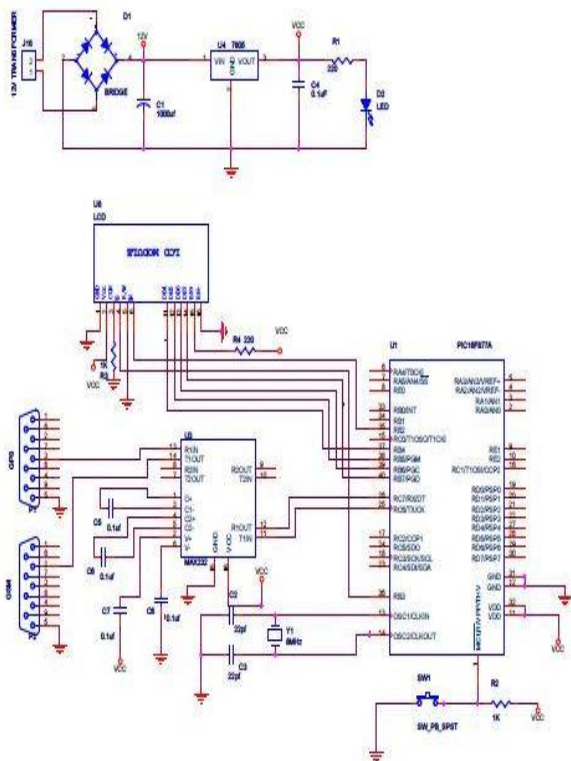

Fig.2. Circuit diagram

The major blocks of this section are power supply, PIC16F877A Microcontroller, GPS, GSM modules, RF Reader, ZIGBEE and a LCD Display. Starting with microcontroller, it has an operating voltage of 3.5 to 5.7V. Hence we use a regulator IC 7805 to provide a constant voltage of 5V and a current of 1A. An LED is provided to indicate whether the power is received. An external crystal of 20MHz is used for clock generation in microcontroller. RF Reader in the Ambulance section is used for reading the RFID tag. This data is then sent to the Traffic Section using ZIGBEE.

LM7805 PINOUT DIAGRAM

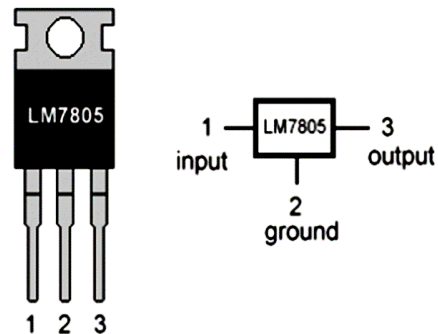

Fig.3. LM7805 IC

The LM 7805 IC is used to regulate the input voltage fed through the step down transformer. It maintains a constant output of 5v dc invariable voltage at the output.

The input to the IC LM 7805 is provided through a step down transformer. The input to the regulator should be at least 2v more than the required output, so here we use a 7v transformer. Hence a 6-0-6 transformer with 500mA .

1. Rectifying circuit

A full wave rectifier circuit is used hence DC saturation is less as in both cycle diode conducts, high transformer utilization factor, 1N4007 has high withstanding capability against reverse voltage even at range of 1000v.

2. Capacitors :

Knowledge of Ripple factor is essential while designing the values of capacitor. It is given by

$$Y = \frac{1}{4\sqrt{3}RCf}$$

Where, f is the frequency, R is the resistance calculated

$$R = \frac{V}{I_c}$$

Where, V is the secondary voltage of transformer C= filtering capacitance

We have to determine this capacitance for filtering

$$Y = \frac{V_{rms}}{V_{dc}}$$

$$V_{rms} = \frac{V_r}{2\sqrt{3}}$$

$$V_{dc} = V_{max} - \frac{V_r}{2}$$

$$V_r = V_{max} - V_{min}$$

Hence the capacitor value is found out by substituting the ripple factor in $Y = \frac{1}{4\sqrt{3}RCf}$

Thus, $C = 2314 \mu F$ and standard $2200\mu F$ is chosen. Datasheet of 7805 prescribes to use a $0.01\mu F$ capacitor at the output side to avoid transient changes in the voltages due to changes in load and a $0.33\mu F$ at the input side of regulator to avoid ripples if the filtering is far away from regulator.

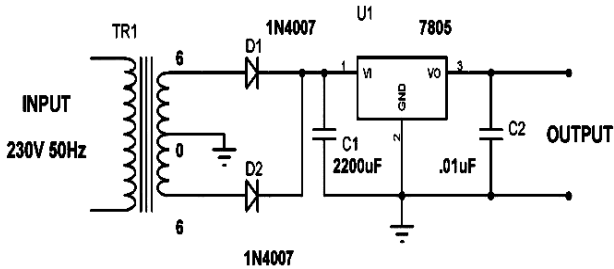

Fig.4. Circuit diagram of power supply unit

• GPS Module

GPS is a network of satellites that continuously transmit coded information, which makes it possible to precisely identify locations on earth by measuring distance from the satellites. GPS receivers are used for position, locating, navigating, surveying and determined of the objects. Using the global positioning system, one's exact location (longitude, latitude and height co-ordinates), the precise time (universal time coordinated, UTC) values can be determined anywhere on earth.



Fig.5. GPS Module

• GSM Module

GSM networks operate in a number of different frequency ranges. Most 2G GSM networks operate in the 900 MHz or 1800 MHz bands. The controller communicates with the mobile phone by AT commands. The Main AT commands to communicate via a serial interface with the GSM subsystem of the phone. The comments that used in the controller is sent and received by SMS (short message system).



Fig.6. GSM Module

• RF ID

Radio-frequency identification (RFID) is the use of an object (typically referred to as an RFID tag) applied to or incorporated into a product, animal, or person for the purpose of identification and tracking using radio waves. Some tags can be read from several meters away and beyond the line of sight of the reader.

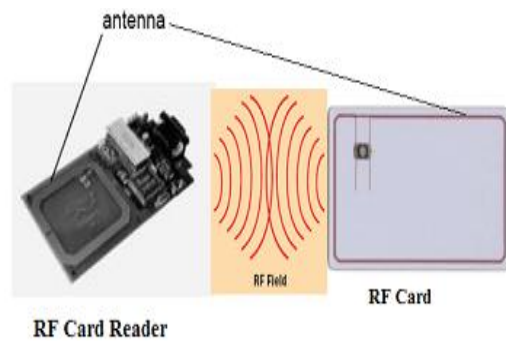

Fig.7. RFID

Most RFID tags contain at least two parts. One is integrated circuits for storing and information, modulating and demodulating a radio frequency (RF) signal, and other specialized functions. The second is an antenna for receiving and transmitting the signal.

• ZIGBEE

The X Bee/Z Bee (formerly known as Series 2 and Series 2 PRO) RF Modules were engineered to operate within the ZIGBEE protocol and support the unique needs of low-cost, low-power wireless sensor networks. The modules require minimal power and provide reliable delivery of data between remote devices. The modules operate within the 2.4 GHz frequency band.

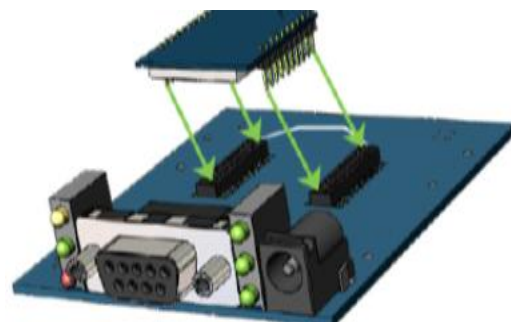

Fig.8. ZIGBEE

B) Traffic section

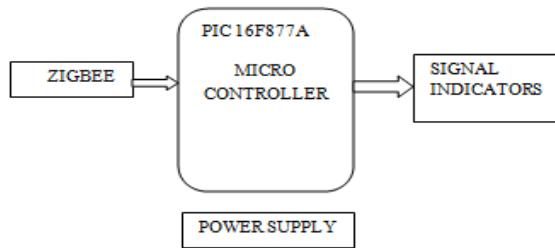

Fig.9. Block diagram of traffic section

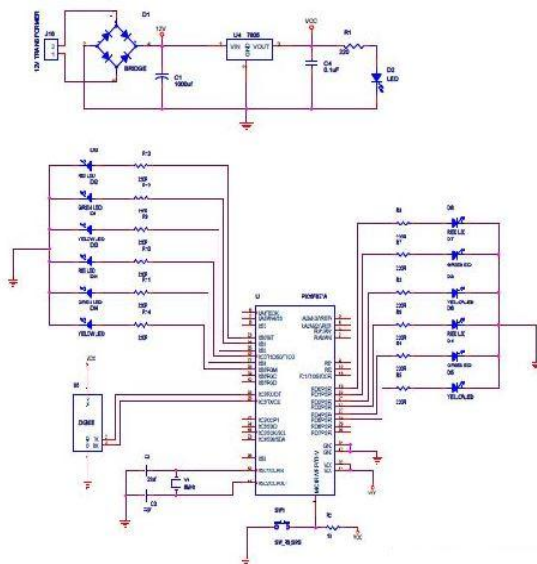

Fig.10. Circuit diagram

The major blocks of this section are power supply, PIC16F877A, ZIGBEE and Traffic lights. When no ambulance is approaching the traffic junction, it works normally. RFID Tags are placed few hundred meters away from the traffic post. When the ambulance approaches the traffic section, RF reader in the ambulance reads the RFID card. This signal is then sent to the traffic section. The PIC Microcontroller is programmed with the codes of all the RFID tags. The code of the RFID tag sent from the ambulance is received using ZIGBEE in the traffic section and is given to the microcontroller. The microcontroller compares the received code with the codes programmed in it, and finds the direction of arrival of the ambulance. Simultaneously the switching of the traffic lights takes place such that the traffic light in the direction the ambulance turns GREEN. This condition withstands until the ambulance crosses the next RFID Tag and finally goes back to the normal working.

• PIC16F877A

PIC micro controllers are low-cost computers-in-a-chip. They allow electronics designers and hobbyists add intelligence and functions that mimic big computers for almost any electronic product or project. The programming of the system is done using a PIC micro controller 16F877. This powerful (200 nanosecond instruction execution) yet easy-to-program (only 35 single word instructions) CMOS

FLASH-based 8-bit micro controller packs Microchip's powerful PIC architecture into a 40-pin package and is upwards compatible with the PIC16C5X, PIC12CXXX and PIC16C7X devices. It has five ports. i.e. port A, port B, port C, port D, port E. The PIC 16F877 has flash memory of 8K and Data memory of 368 bytes Data EEPROM of 256 bytes.

Traffic signal indicators

Light Emitting Diodes (LEDs) of different colors (GREEN, ORANGE, and RED) are used as traffic signal indicators. When no ambulance is approaching the traffic junction, normal working of the traffic signals takes place. On the arrival of the ambulance, switching of the traffic signals happen, i.e., the GREEN LED of the corresponding direction is turned ON.

III. CONCLUSION

The aim of the project is to collect patient from injured location and to switch the traffic lights on the arrival of ambulance based on priority. The existing system only uses the alarm sound through a horn to warn the traffic. The proposed system also warns the hospital about the incoming patient and it is also capable of switching the signal light of its path to green for effortless passing through the main junctions. For this, the device equipped with several General purpose transceivers, vehicle location module and GSM module. ZIGBEE, which is a less expensive and simpler technology, is used for the data transmission between ambulance and traffic sections. A GPS and GSM module in the concerned vehicle will send the location of the ambulance to the hospital. When a status message is sent from the hospital, then GPS system tracks the position of the vehicle and sends the information to the particular mobile number through GSM by alerting the person through SMS. The exact location can also be viewed in Google Map. Hence the time taken from accident location to the hospital can be reduced and also the hospital can be informed about the ambulance location.

REFERENCES

- [1]. Tandrima Chowdhury, Smriti Singh, Dr.S.Mafin Shaby, "A Rescue System of an Ambulance Using Prioritized Traffic Switching", in IEEE sponsored 2nd ICIIECS 2015
- [2]. Ji-chun Zhao, Jun-feng Zhang, Yu Feng, Jian-xian Guo, "The Study and Application of the IOT Technology in Agriculture", in 3rd IEEE International Conference ICCSIT 2010
- [3]. G. Derekenaris, J. Garofalakis, C. Makris, J. Prentzas, S. Sioutas, A. Tsakalidis, "An Information System for the Effective Management of ambulances", 2000
- [4]. S. Jagadeeshwaran, N.Dinesh, "Automatic Ambulance rescue System", 2012