

# Design and Development of Customized Flue Gas and Opacity Monitoring System for Power Plants and Industries

Shivanand Pujari<sup>1</sup>, Shivanandgowda K R<sup>2</sup>

M. Tech Student, Department of Electronics and Communication Engineering, Alpha College of Engineering,  
Bangalore, Karnataka, India<sup>1</sup>

Assistant Professor, Department of Electronics and Communication Engineering, Alpha College of Engineering,  
Bangalore, Karnataka, India<sup>2</sup>

**Abstract:** The flue gas monitoring plays a vital role in thermal power plants as these emissions contribute to the majority of air pollution and global warming. This project proposed to measure concentration method for flue gas of multiple fuels such as natural gas, coal, oil etc based on NDIR & Electrochemical Sensors. Efficiency of power plants becomes more important due to the demand for cost-efficient energy production & tightening environmental regulations. The main objective of the project is to increase the performance of the plant and to protect the environment, thereby giving a pollution free environment for the future generation. The Flue Gas Analyzer measures the amount of Oxygen, combustible gases such as Carbon Monoxide, Carbon Dioxide, Nitrogen Oxides and Sulfur Oxides in the flue with the help of electrochemical Sensors. The measured values of flue gases that are displayed are then compared with their permissible limits.

**Keywords:** Flue Gas analysis, Air pollution and effects, Wireless communication, NDIR, Opacity monitoring system.

## I. INTRODUCTION

Processing of Fuels and generation of energy, the fuels releases sulphur oxides, nitrogen oxides, carbon monoxide, heavy metals, and smoke particulates matter etc into the environment and makes increases in the number of asthma patients over the world, increases the person of getting the disease cancer. The Earth is the reason to increase in the air pollution because of volcanic discharge, large amount fires occurring in the forest, and other few more natural process, but from these types of reason the earth is capable of recover.

If the industrialization is keep on increasing with the fossil fuels means the planet will continue with dangerous loss and makes shortening of life of the all species on the earth. Pollution control board has been paying attention towards controlling the pollution to protect the environment, in terms of reducing industrial emissions and management of risk in chemical use and handling of dangerous waste. Nowadays all pollution control boards are very stricter controls over pollution management. Recent practices to control pollution are that to treatment of end pipe or exhibit at the last.

As the causes from air pollution becoming very crucial because of burning of fuels in a non proper way and over usage of fuels to meet the requirements of human and every life on the planet. The burning of fossil fuels became necessary for all human in the planet for the purposes like using cars, bikes etc. The fossil fuel is burned to bring out

fossil fuel from the Earth, and fossil fuel is used to obtain and process fossil fuel into its different form of components.

## II. RELATED WORK

One of measure problem in Flue gas measurement is Measurement using only NDIR or Electro-Chemical Sensors based there is no analyzers with combination.

And as they use it in power plants and heavy industries so they are quite bulky no portability option like battery based usage.

There are no communication portability such as Wi-Fi, Bluetooth, Zigbee and RS485.

## III. PROPOSED SYSTEM

Measurement using both NDIR and Electro-Chemical Sensors based on sensitivity requirements, as we considered power as a factor to reduce and it should work with the battery with long life.

As it uses battery so it can be portable. Opacity and Smoke Density Measurement of chimney also integrated for few applications wherever necessary. All communication compatibility is there so the instrument can be operated from both machine and mobile or pc.

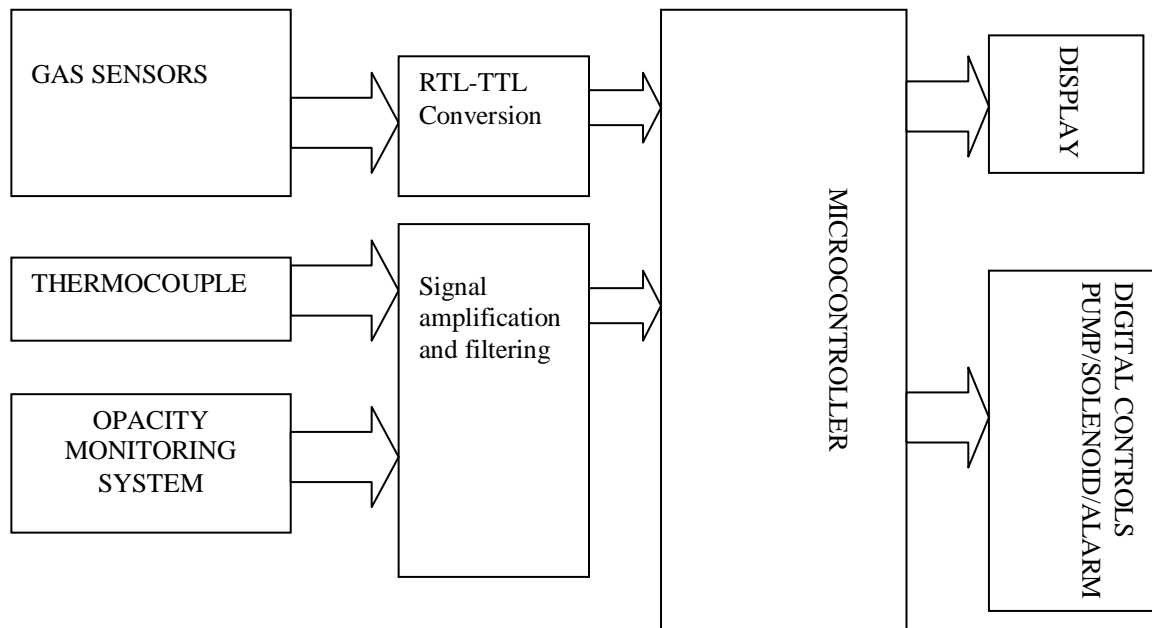

Fig 1: Block diagram of proposed system

**OPACITY MONITORING SYSTEM**

The optic colorimetric principle is used to measure the opacity, using the folded geometry that is high intensity light source and light detector are placed at one side and the opposite side mirror will be fixed to reflect the light back. Based on the light absorption quantity the opacity percentage can be calculated.

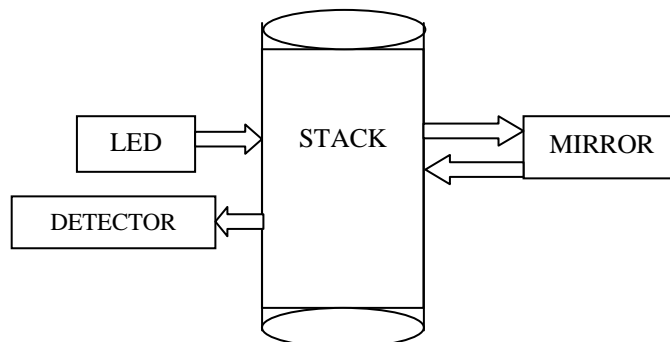

Fig 2: Block diagram of Opacity monitoring system

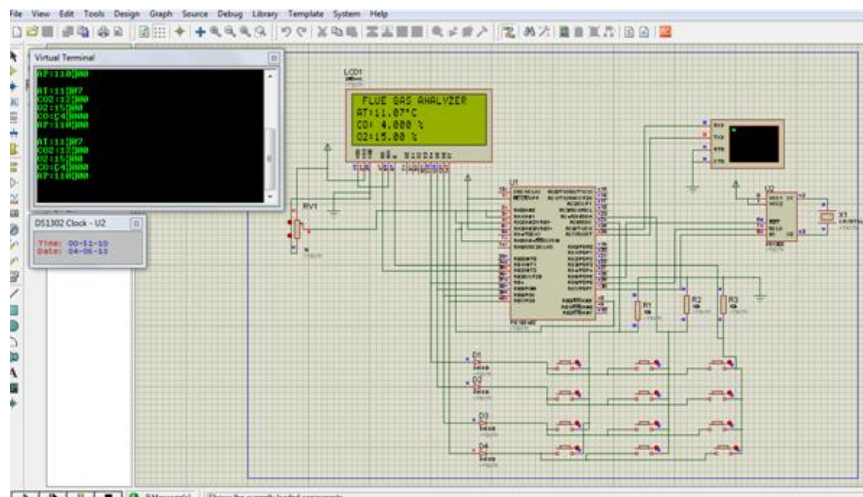

Fig 3: Proteus, a simulated output to verify the program with simulation

Proteus is a tool to simulate the circuit. The complete program can be developed and simulated using proteus software, all microcontrollers, transistors and all types of components are available and they can be rigged up and checked.

#### **IV. CONCLUSION AND FUTURE WORK**

The flue gas analyzer has been developed to measure the flue gases such as Oxygen, Carbon Monoxide, Carbon dioxide, Nitrogen oxides, Sulphur oxides and Temperature with the reference of oxygen. This instrument will be a ready fruit for the pollution control board to create awareness to the industries with modern technology where the plant health is monitored in a proper manner to save environment from toxic gases. In the proposed system, we have employed the use of electrochemical sensors to measure the various gases using a PIC Microcontroller. It overcomes the drawback in the existing systems which use NDIR sensors. Measurement of the various flue outputs from the outlets of industries in terms of its concentration helps to limit exhaust of various unwanted gases into the atmosphere and thereby achieve a pollution free environment. Another important use of Flue Gas Analyzer is that it helps the industries to keep track of the combustion rates. Flue gas analyzer monitors properly the health of plant, when it crosses the set limits means it will give alarm and further if the management not taken care means it will shut off the plant intelligently using program.

The designed module is a prototype of a flue gas analyzer, which can be further advanced to detect a large number of gases using a better set of sensors. The design can also be enhanced to simultaneously detect the emission of gases from automobiles and research engines. The flue gas analyzer now can be see the readings over the world but we cannot communicate to the analyzer. But in future using internet on things we can communicate in two way using a set of encryption proper.

#### **REFERENCES**

- [1]. Nikula, R.-P. Juuso, E. Leiviska, Desulphurization Plant Monitoring and Fault Detection Using Principal Component Analysis, IEEE, 2013
- [2]. Chikere, A.O. Alkayiem, H.H. ; Karim, Z.A.A, Thermal field study and analysis in hybrid solar flue gas chimney power plant, IEEE, 2011
- [3]. Larichkin, J.S. Luchinkin, N. Gorev, Methods of increasing efficiency of flue gas cleaning at thermal power stations equipped with ventury scrubbers, IEEE, 2007.
- [4]. W. Tsujita, S. Kaneko, T. Ueda, H. Ishida, and T. Moriizumi, Sensor-based air-pollution measurement system for environmental monitoring network, IEEE, 2003.
- [5]. P. Zylka B. Mazurek, Rapid Dissolved Gas Analysis by means of Electrochemical Gas Sensors, IEEE, 2002.