

Indoor Asset Tracking System using Wireless Communication

Vaibhav Prasanna Bhandarkar¹, Harshal Girish Narkhede², Aditi Vijay Nerurkar³

BE Student, Electronics and Telecommunications Engineering, MIT COE, Pune, India^{1,2,3}

Abstract: This system locates assets in closed infrastructures like hospitals, factories, IT parks, and large warehouses, where normally Global Positioning System devices don't work. The concept is based on an object tagged with a passive RFID tag, which are read by an RFID reader installed at strategic locations. If you have an outdated asset management system, it's easy to lose track of your resources. Indoor tracking systems provide an extensive solution for companies that require the maintenance of an inventory for tracking their resources, both human and material.

Keywords: Indoor Tracking System (ITS), Location Tracking, Asset Tracking, Asset Management using RFID.

I. INTRODUCTION

Locating Staff Members can be cumbersome in a large infrastructure. Such a problem is faced in many institutions like Engineering Colleges, IT Parks, and even in Hospitals where finding the right doctor in time during emergencies is necessary. Radio Frequency Identification is one of the most popular automatic identification technologies in use these days. This technology is undergoing wide research and development for further advancement in this field for future use. RFID brings concern in security and privacy of users who use these tags in their day to day life.

In the past, RFID has found extensive use in the areas of access control. The use of RFID in educational institutions is effective in solving many typical time consuming problems. It would be convenient if we had a system which would give us the exact location of the person we are looking for. It would save our Time as well as Effort.

II. LITERATURE SURVEY

Positioning has widespread applications in many areas, such as aviation, robotics, and augmented reality. Location Based Services need to provide considerable coverage to track the location of mobile units each equipped with a mobile badge. Services based on location use applications incorporating geographic location with the general notion of services. It's applications include tracking systems, information services, geotagging, etc. Traditionally, satellite systems have been used for obtaining location information. But, satellite systems do not provide a better coverage and precision in indoor environments. Indoor positioning systems are expensive and are only restricted to rooms inside a building. In order to overcome the aforementioned drawbacks, interests played by RFID in such applications has started to grow since 1990's. RFID technology makes use of radio signals to track, sort and detect a variety of assets without the need for direct contact or line of sight contact [9]. RFID technology can

track the movements of assets through a network of detectors over a distance of several meters [9]. Owing to such benefits, countless attempts have been made to use RFID technology in positioning.

However, all the above studies involve the use of active RFID tags for positioning purposes, whereas this paper attempts to employ a passive solution which is less - expensive and more cost-effective to serve the purpose [9].

III. OVERVIEW OF RFID TECHNOLOGY

RFID system consists of three components transponder, reader and computer containing database [10]. The reader reads the tag id and transmits it to the computer for authentication. Information is processed, verified and then displayed. RFID system operates in four frequency ranges low, high, ultra-high and microwave. Low frequency RFID system operates at 125 KHz-135KHz and has a reading range of less than 0.5m. High frequency system operates at 13.56MHz and provides a reading range of 0.9m - 1m. Similarly, Ultrahigh and Microwave frequency system operates at 902-928 MHz and 2.4 GHz and provide reading range of 3m and 1m respectively.

RFID tags are of two types active and passive [10]. The active tags require an inbuilt battery for powering the circuit which makes them expensive. On the other hand, passive tags power their circuit using energy provided from the reader, and are more cost effective. This paper proposes the use of passive RFID tags. A passive RFID tag transmits its information to the reader when it comes in the region of reader's electromagnetic field. The current flowing through the coil of reader produces a magnetic field which links to the transponder coil thereby producing a current in the transponder coil [10]. The transponder coil then varies that current by changing the load on its antenna. This variation is actually the modulated signal which is received by the reader coil through mutual

induction between the coils [10]. The reader coil decodes this signal and passes to the computer for further processing [10].

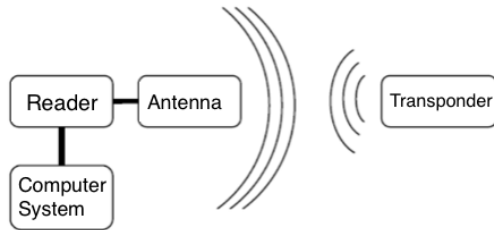

Fig. 1 Basic RFID System

IV. SYSTEM COMPONENTS

A. RFID Tag

RFID tag consists of a microchip attached to a radio antenna and it can be attached to the object to be tracked. The tag's antenna picks up a signals from an RFID reader and returns the data stored on the microchip.

B. RFID Reader

RFID Reader Module works with the RFID tag operating at a frequency of 125KHz issued to the user and a reading distance of 10 cm [10]. An RFID reader is a device that provides the connection between the tag data and server. The antenna of reader emits radio waves that capture data from the tag. It then passes the data to the server for processing. EM-18 module is a type of low frequency RFID reader that connects to any micro controller UART or through a RS232 converter to PC.

C. Microcontroller

The PIC micro controller PIC16F877a is one of the most popular micro controllers in the industry. This controller is very convenient to use, cost effective and easy to program. It uses FLASH memory which enables the user to program the chip multiple times. It has a total number of 40 pins out of which 33 are GPIO's.

PIC16F877a has widespread applications in remote sensors, home automation, security and safety devices, and in many industrial instruments. It also has EEPROM for permanent storage of data.

D. ESP 8266

The ESP8266 is a Wi-Fi Module which has an integrated TCP/IP protocol stack. It helps in providing Wi-Fi connectivity to any micro controller. ESP8266 makes it possible to either host an application or offload all Wi-Fi networking functions from another application processor. An ESP8266 module is controlled by using AT commands and comes pre-programmed with an AT command set firmware.

E. Server

Location related information from every door unit would be sent to the server. Server performs various functions like identifying the particular door unit that has sent data,

checking validity of received data and processing it to extract location related information.

V. SYSTEM OPERATION

The proposed system makes use of RFID technology to track the location of staff members of any large organisation systematically. RFID systems uses emitted radio waves from the reader to transmit tag information through a wireless communication to a host computer. The reader communicates with the tags in its wireless range and collects information about the objects to which tags are attached.

The system has three functional units: the tags, the door unit and the server:

A. RFID Tag

A tag would be embedded within the id card of each staff member. The cards used are low frequency passive cards which are cost effective as well as small enough to fit within the id card. They can be detected up to a distance of 10 cm and operate at a frequency of 125 KHz. Each tag has a unique 12-character long id.

B. The Door Unit

This unit would be installed outside every door. It would consist of an RFID reader, a micro controller and a WiFi module. Every staff member would bring their id cards within a close proximity of the reader while entering any room. The reader used is EM-18 which works with 125 KHz passive tags. This reader is connected to the PIC16F877A micro controller via the Rx pin of the serial port. The data read by the reader is given to the micro controller for processing. The micro controller then sends this data to the remote server using the ESP8266 WiFi module connected to the Tx pin of its serial port.

C. The Server

The server would receive data over TCP/IP. This data would be stored in a database. The server would process this data and display it on Graphical User Interface (GUI). The GUI would consist of a floor plan of the building and location of the personnel would be indicated on it.

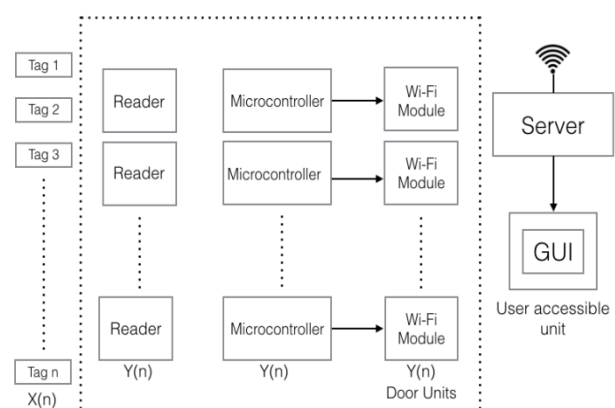

Fig. 2 Block diagram for the proposed system

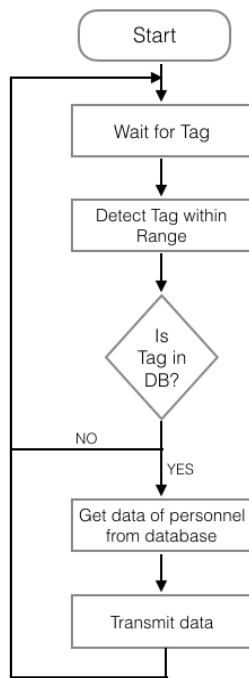

Fig. 3Flow at data unit

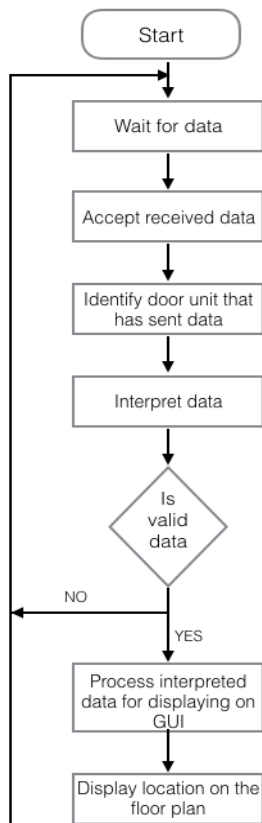

Fig. 4Flow at Server

The server would process the received data and display it in the form of a graphical user interface (GUI). The GUI would consist of a floor plan of the building and location of the personnel would be indicated in the same. This interface would be part of a user accessible unit with

provision to search for any required personnel. The proposed GUI has considerable advantages over traditional textual displays which tend to be monotonous.

The proposed system makes use of RFID technology to track the location of staff members of any large organisation systematically. RFID systems uses emitted radio waves from the reader to transmit tag information through a wireless communication to a host computer. The reader communicates with the tags in its wireless range and collects information about the objects to which tags are attached.

VI.RESULT AND DISCUSSION

The research paper discusses about how to monitor the movements of an object tagged with a RFID chip. The RFID EM-18 Module monitors the asset’s location which is simultaneously updated on the server and is accessed through a webpage based on name assigned to the asset. The tags can be detected efficiently by the reader upto a distance of 6-8cm. The data which is read is given to the micro controller and then to the ESP 8266 Wi-Fi module which sends this data to the server side using peer to peer communication. The assets name can be searched through a webpage as shown in Fig. 5 and the location in the form of room number is extracted from the server database and is displayed corresponding to the assets name searched as shown in the Fig. 6. This system accurately identifies the location of the asset tagged with a RFID chip.



Indoor Tracking System using Wireless Communication

Enter the name of person for checking his current room location

Enter name : Harshal Narkhede

Search

Fig. 5Webpage for searching asset based on its name

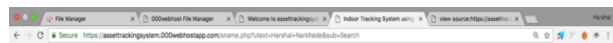

Indoor Tracking System using Wireless Communication

Room number corresponding to the name entered is displayed

ID :	1
Name :	Harshal Narkhede
Room Number :	506

Fig. 6GUI for obtaining the location of the asset searched

VII. CONCLUSION

The proposed system makes use of RFID technology to track the location of staff members of any large organisation systematically. RFID systems uses emitted

radio waves from the reader to transmit tag information wirelessly to a host computer. The tag information of the tags in the wireless range of reader gets stored in the server database. This indoor tracking system is based on the detection of a passive tag attached to an asset. At low frequency, the distance upto which a tag can be detected is upto 10cm. Higher frequency active tags give better range (upto few hundred meters). Passive tags used in this system are cost effective as compared to their active counterparts. If large quantities of the assets are to be located, then the average cost of using the system will become lower due to these tags. Thus, the system provides a cost efficient solution for location tracking. This trend of indoor positioning systems is used for tracking assets in an indoor infrastructure, and there is trend of of developing such indoor tracking systems.

REFERENCES

- [1] Chong Wang, Hongyi Wu, and Nian-Feng Tzeng, "RFID-Based 3-D Positioning Schemes," in Proceedings of IEEE INFOCOM 2007.
- [2] P. Youngsu, W.L. Je, K. SangWoo, "Improving position estimation on RFID tag floor localization using RFID reader transmission power control," Robotics and Biomimetics, 2008. ROBIO 2008. IEEE International Conference (2009) 1716–1721
- [3] M. Bouet, G. Pujolle, L-VIRT, "A 3-D range-free localization method for RFID tags based on virtual landmarks and mobile readers," Consumer Communications and Networking Conference, CCNC 2009. 6th IEEE (2009) 1–5
- [4] F. Manzoor, H. Yi, K. Menzel, "Passive RFID-based indoor positioning system: an algorithmic approach," RFID-Technology and Applications (RFID-TA), IEEE International Conference (2010) 112–117
- [5] H. Koyuncu, S.H. Yang, "A survey of indoor positioning and object locating systems," IJCSNS Int. J. Comput. Sci. Network Secur., 10 (5) (2010), pp. 121–128. Y. Yorozu, M. Hirano, K. Oka, and Y. Tagawa,
- [6] H. Liu, H. Darabi, P. Banerjee, J. Liu, "Survey of wireless indoor positioning techniques and systems," IEEE Trans. Syst. Man Cybern. Part C (Appl. Rev.), 37 (6) (2007), pp. 1067–1080
- [7] M. Banitalebi-Dehkordi, J. Abouei, K.N. Plataniotis, "Compressive- sampling-based positioning in wireless body area networks," Biomed. Health Inf. IEEE J., 18 (1) (2014), pp. 335–344
- [8] M. Brandl, , T. Posniecek , K. Kellner Position, "Estimation of RFID- based sensors using SAW compressive receivers," (2016)
- [9] S.L. Ting, S.K. Kwok, Albert H.C. Tsang and George T.S. Ho, "The Study on Using Passive RFID Tags for Indoor Positioning" International Journal of Engineering Business Management, 2011
- [10] Farooq, Umar, K.M Hasan, Faiqa Rafiq, and Muhammad Usman Asad, "An integrated approach towards designing an embedded wireless monitoring and access control system using RFID and MMS technologies" Multi Topic Conference (INMIC), 2013 16th International