

The Instantaneous Advanced Water Quality Monitoring System using IoT

Reetesh Golhar¹, Apurva Sakle², Harshali Warhate³, Isha Ninawe⁴, Ankita Bodhale⁵

Asst. Professor, Department of ETC, DMIETR, RTM Nagpur University, Wardha India¹

BE Student, Department of ETC, DMIETR, RTM Nagpur University, Wardha (M.S.), India²⁻⁵

Abstract: Today's world, Internet of Things (IoT) and Remote Sensing (RS) techniques used in different area of research for monitoring, collecting and analyzing data from remote locations. Drinking water is a very precious commodity for all human beings as drinking water utilities face a lot of new challenges in real-time operation. These challenges originate because of limited water resources, growing population, ageing infrastructure etc. therefore there is a need for better methodologies to monitor the water quality. Any imbalance in water quality would severely affect the health of the humans, animals and also affect the ecological balance among species. The WHO (world health organization) estimated, in India among 77 million people is suffering due to not having safe water. WHO also estimates that 21% of diseases are related to unsafe water in India. In order to ensure the safe supply of drinking water the quality needs to be monitored in real-time. The conventional method of measuring the quality of water is to take the samples manually and send it to laboratory for analysis. This technique is time overwhelming and not economical. Also it is not feasible to take the water sample to the laboratory after every hour for measuring its quality. To overcome from these problems a new system is proposed in this work. This water quality measuring system will measure the essential qualities of water in real time. In this research work we intend to present the design and development of a low cost system for real monitoring of water quality in an IoT environment. The system consists of several sensors which are used for measuring physical and chemical parameters of water. The parameters such as temperature, pH and turbidity of the water can be measured. The measured values from the sensors can be processed by the core controller. Using this system a person can detect pollutants from a water body from anywhere in the world.

Keywords: Water Quality Monitoring, IoT, Arduino, Sensors, Microcontroller

I. INTRODUCTION

21st century is century of pollution, global warming, insecurity and vulnerable health factors. Water pollution is the major problem in front of world today, which is nothing but the contamination of water bodies. Water pollution occurs when contaminants are discharged directly or indirectly into water bodies. Water pollution affects plants and creatures living in these bodies of water. Also human health is affected by polluted water. Water Pollution is a major global problem which requires ongoing valuation and modification of water resource guiding principle at the levels of international down to individual wells. It has been surveyed that water pollution is the leading cause of deaths and diseases worldwide. The records show that more than 14,000 people die daily worldwide. In India predictable 580 people die of water pollution related illness every day. In many developing countries, dirty or contaminated water is being used for drinking without any proper former treatment. One of the reasons for this happening is the unawareness of public and administration and the lack of water quality monitoring system which creates serious health issues. Also natural phenomena such as volcanoes, algae tints, rainstorms, and earthquakes also change the quality and ecological status of water. As water is the most important factor for all living organisms it is very important to protect it. And water quality monitoring is one of the first steps required in the rational development and management of water resources. Thus in this research work we describe the design of Wireless Sensor Network (WSN) that helps to monitor the quality of water with the help of information sensed by the sensors immersed in water, so as to keep the water resource within a standard described for domestic usage and to be able to take necessary actions to restore the health of the degraded water body. Using different sensors, this system can collect various parameters from water, such as temperature, pH and turbidity. The rapid development of wireless sensor network (WSN) technology provides a novel approach to real-time data acquisition, transmission and processing. The clients can get ongoing water quality information from faraway. By looking above issues, we developed and designed a low cost water quality monitoring system that can monitor water quality in real time using IOT environment. In our proposed system water quality parameters are measured by the different water quality monitoring sensors such as pH, turbidity, and temperature. These sensor-values are processed by the microcontroller. The processed data can be monitored through a browser application using a special IP address. Furthermore, with the help of IOT environment, we can provide facility to access data remotely from all over the world.

II. RELATION WITH IoT

The Internet of Things (IoT) is an important topic in technology industry, policy, and engineering circles and has become headline news in both the specialty press and the popular media. This technology is embodied in a wide spectrum of networked products, systems and sensors which take advantage of advancements in computing power, electronics miniaturization, and network interconnections to offer new capabilities not previously possible. IoT systems like networked vehicles, intelligent traffic systems, and sensors embedded in roads and bridges move us closer to the idea of “smart cities”, which help minimize congestion and energy consumption.

This section explains the block diagram of proposed water quality monitoring system. It explains the connection between each component used.

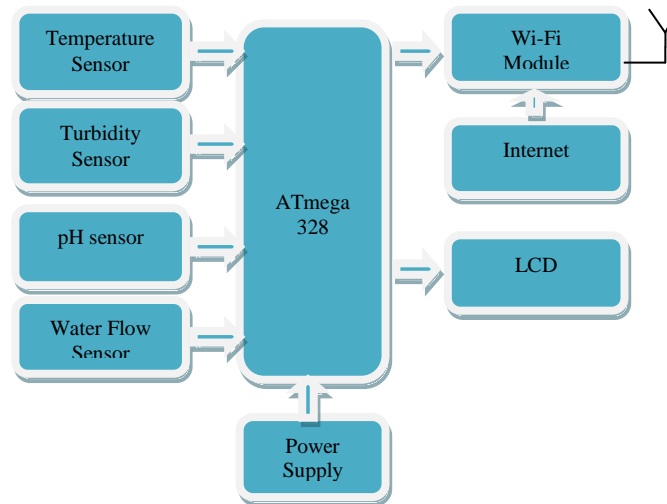

Fig. 1 overall system architecture

This figure consists of several sensors like pH, temperature, conductivity, turbidity and water level sensors; these are connected to the ATmega 328. The core controller are accessing the values and processing them to transfer the data through internet. Arduino is used as a core controller. The information will be uploaded continuously from the WSN through Microcontroller and Wi-Fi.

Arduino can sense the environment by receiving input from a different sensor (temperature, PH, Turbidity) and send the data to cloud enabled system. The microcontrollers on the board is programmed using Arduino programming language based on wiring and Arduino development based on processing. We control and upload this data to cloud and users can access this data through Blynk application by installing it into their phones. From this system a person from anywhere can monitor the information at any time.

A. Arduino

Arduino is an open source computer hardware and software company, project and user community that designs and manufactures single-board microcontrollers and microcontroller’s kits for building digital devices and interactive objects in the physical world. Arduino boards are available commercially in preassembled form, or as do-it-yourself kits. Arduino board designs use a variety of microprocessors and controllers. The boards are equipped with sets of digital and analog input/output (I/O) pins that may be interfaced to various expansion boards and other circuits.



Fig. 2 ATmega 328 chip

The ATmega 328 is a single-chip microcontroller created by Atmel in the mega AVR family. The Atmel 8-bit AVR RISC-based microcontroller combines 32 kB IPS flash memory with read-while-write capabilities, 1 kB EEPROM, 2 kB SRAM, 23 general purpose I/O lines, 32 general purpose registers, three flexible timer/counters with compare modes, internal and external interrupts, serial programmable USART, 6-channel 10-bit A/D converter, programmable watchdog timer with internal oscillator, and five software selectable power saving modes.

Overview of water quality sensors

1) Temperature Sensor: This is a pre-wired and waterproof version of the DS18B20 sensor. Handy for when you need to measure something far away, or in wet conditions while the sensor is good up to 125°C the cable is jacketed in PVC so we suggest keeping it under 100°C.

2) Turbidity Sensor: Turbidity is the or haziness of a fluid caused by large numbers of individual particles that are generally invisible to the naked eye, similar to smoke in air. The measurement of turbidity is a key test of water quality. The world health organization, establishes that the turbidity of drinking water should not be more than 5 NTV and should ideally be below 1 NTV (Nephelometric Turbidity Units).

3) pH Sensor: pH stands for power of hydrogen, which is measure of the hydrogen ion concentration. The total pH scale ranges from 1 to 14, with 7 is said to be acidic and solution with a pH greater than 7 are basic or alkaline. The pH meter measures the difference in electrical potential between a pH electrode and a reference electrode.

4) Flow Sensor: YF-S201 Water Flow Sensor can be used to measure the flow of liquids in both industrial and domestic applications. This sensor basically consists of a plastic valve body, a rotor and a Hall Effect sensor.

Circuit Diagram

The whole design of the system is based mainly on IOT which is newly introduced concept in the world of development. There is basically two parts included, the first one is hardware & second one is software. The hardware part has sensors which help to measure the real time values, another one is Arduino. The hardware part consist sensors like turbidity, flow, pH and temperature. Turbidity sensor is used to measure cloudiness of water. Cloudiness is caused by suspended solids (mainly soil particles) and plankton (microscopic plants and animals) that are suspended in the water column. Moderately low levels of turbidity may indicate a healthy. Water Flow Sensor can be used to measure the flow of liquids in both industrial and domestic applications. PH stands for Power of Hydrogen, which is measure of the hydrogen ion concentration. Temperature sensor used to monitor the temperature of water. The outputs of sensors are given to the ATmega 328 controller. It converts the analog values to digital one, & LCD shows the displays output from sensors, Wi-Fi module gives the connection between hardware and software.

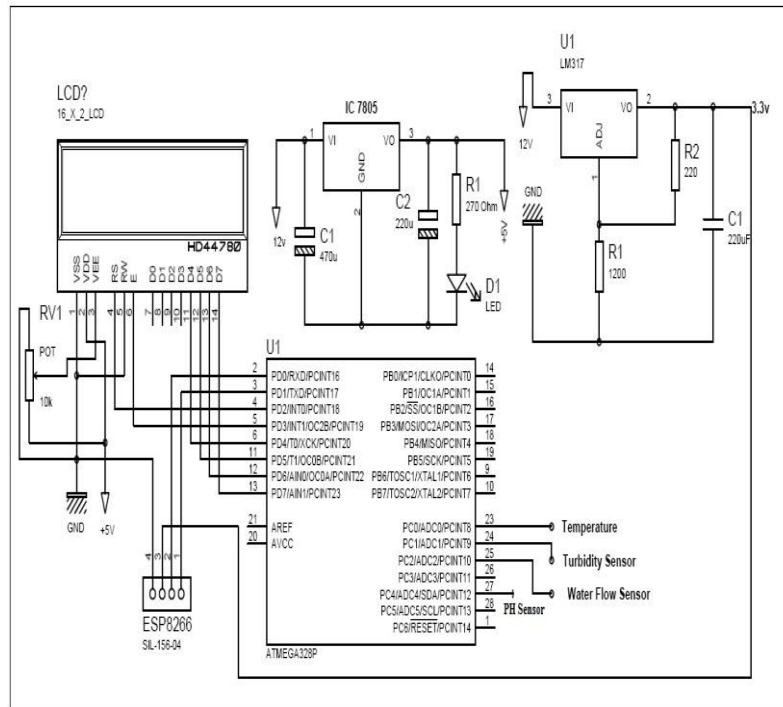

Fig. 3 Overall Circuit Diagram

The software system of this project is developed by embedded C Language. The PCB is design at first level of construction and component and sensors mounted on it. BLYNK app is installed in the android version to see the output. When the system gets started dc current given to the kit and Arduino and Wi-Fi gets on. The parameters of water are tested and their results are given to the LCD display. The app will provided with hotspot gives the exact value as on LCD display shows on kit. Thus like this, when the kit is located on any specific water body and Wi-Fi is provided we can observe its real time value on our android phone anywhere at any time.



III. CONCLUSION

This research work shows the approach to water quality monitoring. The proposed system consists of several water quality parameter sensors core controller and an IoT module. These devices are low cost, more efficient and capable of processing, analysing, sending and viewing the data on cloud and also through WIFI to mobile device. This can implement is suitable for environment monitoring, ecosystem monitoring, etc. and the data can be viewed anywhere in the world.

REFERENCES

- [1] Nikhil Kedia, Water Quality Monitoring for Rural Areas-A Sensor Cloud Based Economical Project, 978- 1-4673-6809- 4/15/\$31.00 ©2015 IEEE.
- [2] N. Vijayakumar, R. Ramya, The Real Time Monitoring of Water Quality in IoT Environment, vol.4 Mar 2015.
- [3] Jayti Bhatt, Jignesh Patoliya, IOT Based Water Quality Monitoring System, vol. 4, Issue 4, Apr 2016.
- [4] Nidal Nasser1, Asmaa Ali, Lutful Karim, Samir Belhaouari ,An Efficient Wireless SensorNetwork-based Water Quality Monitoring System 978 1-4799-0792 2/13/\$31.00 ©2013IEEE.