



WI -Intercom

Anjali NR¹, Aswathi Vidya Sagar², Habeeba Jabin PK³

Student, Department of Electronics & Communication, SIMAT, Vavanoor, India ^{1,2,3}

Abstract: This project is designed to develop a communication system where we can make Wi-Fi call within a specified LAN along with smart reservation system. The LAN is defined by Wi-Fi router, wireless accesspoint and raspberry pi. Raspberry pi act as the server of asterisk which perform the functions of a conventional PBX. This system is developed for institutional or organization point of view so that we could connect various departments and section under a controlling unit.

Keywords: Wi-Fi, asterisk, LAN.

I. INTRODUCTION

Communication between two personalities in industries, hospitals, rural areas and colleges for any type of work is needed in case of emergency and for personal communication. For this we have to install wired connection using intercom communication, LAN, WAN, MAN internet protocols, RFID and IR communications, WIFI, Zigbee for communication between PCs and other devices. For all this connection we have to pay charges for short range communication. The existing Intercom (intercommunication) device is a voice communication system used within a building or small collection of buildings. It is mounted permanently in buildings. There are two types of intercom technology available today-wired intercoms and wireless inter-coms. Both techniques need a switching network called PBX (Private Branch Exchange). A huge investments have to be done by the companies or institution to purchase a PBX.

This project is an implementation to the idea of the wireless communication between two smartphones or a smartphone and a telephone module. In proposed system, it is used for the reservation of venue/location/time like seminar halls, auditoriums, etc. using Wi-Fi call without using internet and network service providers. This system makes the communication within the organisation area (LAN) cost effective and wireless.

DESCRIPTION

LAN consists of router, switch, hub and WAP. LAN is connected to the IP to PSTN converter using RJ45 cable. RJ11 from the IP to PSTN converter is connected to the telephone module and the DTMF decoder. Telephone module is the section where it receives and transmits the call. When a phone call arrives, the DTMF decoder will decode the number and sends the information to the microcontroller, ATMEGA328. Microcontroller will check the corresponding number in its memory location. If the received number is an authenticated number, the call will be picked up automatically. Otherwise, the call will be

disconnected. Call picking process takes place by keeping the port high. Then using a 6-channel relay, the call is automatically picked up. Receiver section has a speaker and a mike. To the mike section, signal from the APR module is given. The APR module is the section where we can save the necessary audios. By making each port in high voltage position, the corresponding audio will be played. 8 audio files can be saved in this APR module. The output from the speaker is given to the input of the mike. When the call is automatically picked up, the microcontroller will play the first audio file. The user can press certain number corresponding to the message from the audio. The pressed number is again decoded by the DTMF decoder and again sent to the microcontroller. Reservation is done at this section. Call will be terminated after pressing the termination number or when the reservation has done.

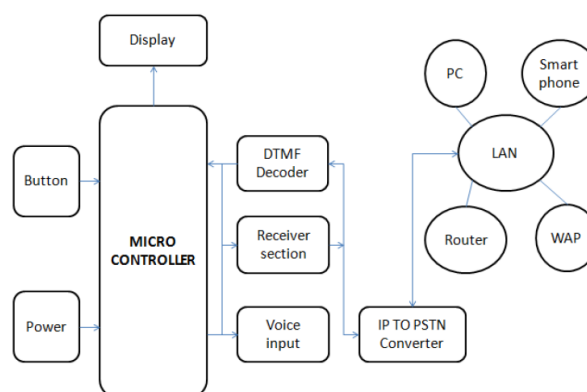

Fig: Block Diagram of Wi-INTERCOM

II. CONCLUSION

Wi-intercom has been successfully designed and tested. It has been developed by integrating features of all hardware components used. Presence of every module has been



reasoned out and placed carefully thus contributing best working of the unit. Finally, concluded that Wi-intercom is a cost free communication system without internet and network service providers. This can be used in institutions. Future work can be extended to make external call, i.e., not in the specified LAN area.



Habeeba Jabin PK, Student, Department of Electronics and Communication Engineering, Sreepathy Institute of Management and Technology, Vavanoor, India.

ACKNOWLEDGMENT

We are grateful to our professors **Sreebala P, Sushma M, Sugesh, Sreeja P** for their proper guidance and support. Many colleagues reviewed the drafts and we owe them our thanks.

REFERENCES

- [1] Mohammed A qadeer, "encrypted voice calls with ip enabled wireless phones over GSM/CDMA/WIFI networks", In IEEE international conference on computer engineering and technology, 2009.
- [2] Miguel edo, " IP telephony development and performance over IEEE 802.11g", 2009 5th international conference on networking and services.
- [3] Aws naser jaber, "a study of SIP trunk security and challenges", 2012 IEEE international conference on electronics design, systems and application (ICEDSA).
- [4] Faroudja abid, 'embedded implementation of an IP-PBX/VOIP gate way ", 2012 24th international conference on microelectronics (ICM)
- [5] Md.zaidulalam, "small office PBX using voice over Internet protocol (VOIP)", IEEE international conference feb 12-14, 2007.
- [6] Krishna sumanathchava, "integration of open source and enterprise IP PBXs", IEEE international conference on 2012
- [7] Mohammed azaam khan, "asterisk based open source IP-PBX system for accountable customer support service", 2015 3rd international symposium on computational and business intelligence.
- [8] Xuehua yang, " research of a service monitoring system based on SIP in hybrid network", 2009 ninth international conference on hybrid intelligent systems.
- [9] Lukas kopicak, "remote control of asterisk via web services", IEEE international conference 2011.
- [10] Mohammed a qader, " Asterisk Voice exchange: an alternative to conventional EPBX", 2008 international conference on computer and electrical engineering.
- [11] S Nagakishore Bhavanam, "Zynq 7000 series FPGA based Efficient DTMF detection", IEEE international 2014.

BIOGRAPHIES



Anjali NR, Student, Department of Electronics and Communication Engineering, Sreepathy Institute of Management and Technology, Vavanoor, India.

A. Swathy Vidyasagar, Student, Department of Electronics and Communication Engineering, Sreepathy Institute of Management and Technology, Vavanoor, India.