



Three Level Inverter Based Dynamic Voltage Restorer for Power Quality Improvement

Mithun K¹, Dr. Jayaprakash P¹

Department of EEE, Government College of Engineering, Kannur, Kerala, India¹

Abstract: The power quality (PQ) in distribution systems is principally affected by the pollution introduced by the customers. It is necessary to protect the sensitive loads from disturbances such as sags, swells, source voltage imbalances, etc. The actual solution for this case is to employ a dynamic voltage restorer (DVR) device. Dynamic Voltage Restorer (DVR) is a series connected compensators. A DVR has to supply energy to the load during the voltage sag and swell. The use of multilevel inverters in DVR improves the harmonic performance of the System. The synchronous reference frame based control is used for the DVR control. In this paper the design and simulations of three level inverter based DVR is discussed. A three level inverter based DVR and a two level inverter DVR is simulated in MATLAB software and the results are analysed. From the result it is observed that load voltage is maintained at reference value by injecting a series voltage and the load voltage THD is improved by employing the three level inverter.

Keywords: PQ-Power Quality, DVR-Dynamic Voltage Restorer, THD-Total Harmonic Distortion, PWM-pulse width modulated.

I. INTRODUCTION

Voltage sag is defined as a sudden reduction of the supply voltage to less than 90% of the rated voltage, according to EN 50160 [1]. Voltage sag is considered an important factor in electric system power quality particularly with the proliferation of electronic devices sensitive to electrical disturbance [2]. In textile and paper mills, a brief voltage sag may potentially cause an adjustable speed drive (ASD) to introduce speed fluctuations which can damage the end product. Furthermore, a brief voltage sag also causes a momentary decrease in dc-link voltage, triggering an under voltage trip or resulting in an overcurrent trip. Such nuisance tripping of ASD equipment employed in continuous process industries contributes to loss in revenue and can incur other costs

As a remedy, the uninterruptible power supply (UPS) is used for protecting loads from voltage disturbances such as voltage sags or outages. However, in high power ratings, the UPS is not able to support the load. Therefore, the need exists to find a device that supports the load without replacing the supply. Connecting a dynamic voltage restorer (DVR) in series achieves the objective. The DVR (shown in Fig. 1) is a power-electronic based device used for supporting the load voltage during supply voltage sag and can be extended to include voltage swell compensation.

The Dynamic Voltage Restorers are mostly used for voltage sag mitigation purposes. Dynamic Voltage Restorer (DVR) are series connected compensators.. A DVR has to supply energy to the load during the voltage sags. If a DVR has to supply active power over longer periods, it is convenient to provide a shunt converter that is connected to the DVR on the DC side. The DVR can inject a (fundamental frequency) voltage in each phase of required magnitude and phase power.

The DVR has been discussed in literature [3]–[6]. The first DVR was installed in 1996 for the Electric Power Research Institute on the Duke Power Company in North Carolina by Westinghouse

II. LITERATURE SURVEY

A power electronic converter based series compensator that can protect critical loads from all supply side disturbances other than outages is called a dynamic voltage restorer (DVR). The restorer is capable of generating or absorbing independently controllable real and reactive power at its AC output terminal. This device employs solid-state power electronic switches in a pulse-width modulated (PWM) inverter structure. It injects a set of three phase AC output voltages in series and synchronism with the distribution feeder voltages. The amplitude and phase angle of the injected voltages are variable there by allowing control of the real and reactive power exchange between the device and the distribution system. The DC input terminal of the restorer is connected to an energy source or an energy storage device of appropriate capacity. The reactive power exchanged between the restorer and the distribution system is internally



generated by the restorer without AC passive reactive components. The real power exchanged at the restorer output AC terminals is provided by the restorer input DC terminal from an external energy source or energy storage system.

The DVR functions by injecting three single phase AC voltages in series with the three phase incoming network voltages during a dip, compensating the difference between faulty and nominal voltages. All three phases of the injected voltages are of controllable amplitude and phase. Voltage source inverter fed from the DC link supply the required active and reactive power. If the grid voltage is higher than 90% or lower than 50%, the DVR is in standby mode. If the grid voltage is between 50% and 90%, the DVR starts supporting the load voltage. In normal operation, the injected series voltage is zero either via control of the DVR (either the upper or lower three switches are on) or using a bypass switch. If the load current exceeds a threshold limit, the bypass switch is closed to protect the DVR at low voltage (LV), the DVR is usually implemented with the classical two-level voltage source converter (VSC) via a coupling voltage transformer. In medium voltage (MV) and high power applications, the switches of the two-level topology must block high voltages. Otherwise, a transformer with high turns ratio will be need, increasing both the current in the converter side and the losses in the DVR. In MV applications it is more appropriate to implement the DVR with a multilevel voltage source converter (MVSC) [7]-[13]. In this way it is possible to reduce the current and losses in the converter. Moreover, it is feasible to combine the action of the DVR with a shunt compensator, sharing the DC bus in a back to back connection.

There are different types of multilevel inverters are used for DVR application. This include Diode Clamped multilevel inverter based DVR, Transformer Coupled H-Bridge Converter Applied To DVR [8], Multilevel Inverter With Adjustable Dc-Link Voltage [9], Cascade Asymmetric Multilevel Converter (CAMC)[11], Dynamic Voltage Restorer Based On Flying Capacitor Multilevel Inverter[11], Cascaded Multilevel Inverter DVR [12]. Among these configurations Diode Clamped Multilevel inverter [13] DVR is simple in structure and control. This is cost effective also this paper proposes a DVR employing Three Level Diode Clamped inverter. The simulation study of the DVR is done and the performance is comparing with two level inverter based conventional DVR.

III. PROPOSED DVR TOPOLOGY

Fig 1 shows the block diagram representation of the proposed DVR topology. The major components of the proposed DVR include three phase three level Diode Clamped inverter, LC filter, battery energy storage system, Injection Transformer and control circuit.

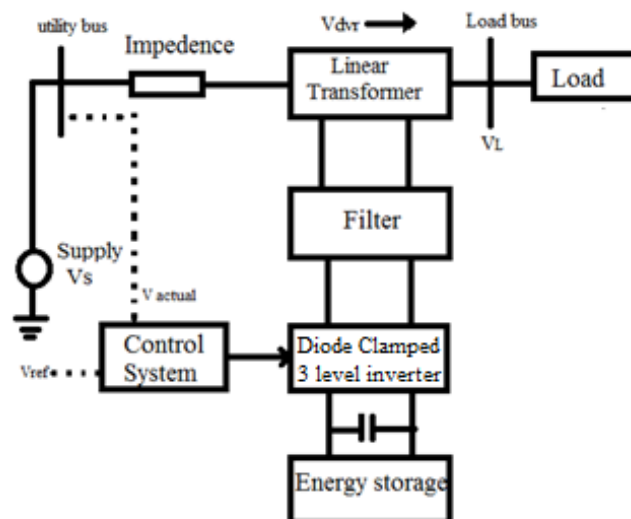

Fig 1. Proposed DVR Configuration

In DVR application to convert the DC voltage into an AC voltage a Voltage Source Inverter is used. Generally PWM two level Voltage Source Inverter is used in DVR. Here a Diode Clamped Three Level inverter is used. Fig 2 shows the circuit diagram of a Diode Clamped Three level inverter. It consist of 4 switches in each leg and 4 clamping diodes. The input DC voltage of the inverter is $V_{dc}/2$ in each voltage source. The mid- point is grounded. In order to boost the magnitude of voltage during sag, in DVR power circuit a step up voltage injection transformer is used. Thus an inverter with a low voltage rating is sufficient.

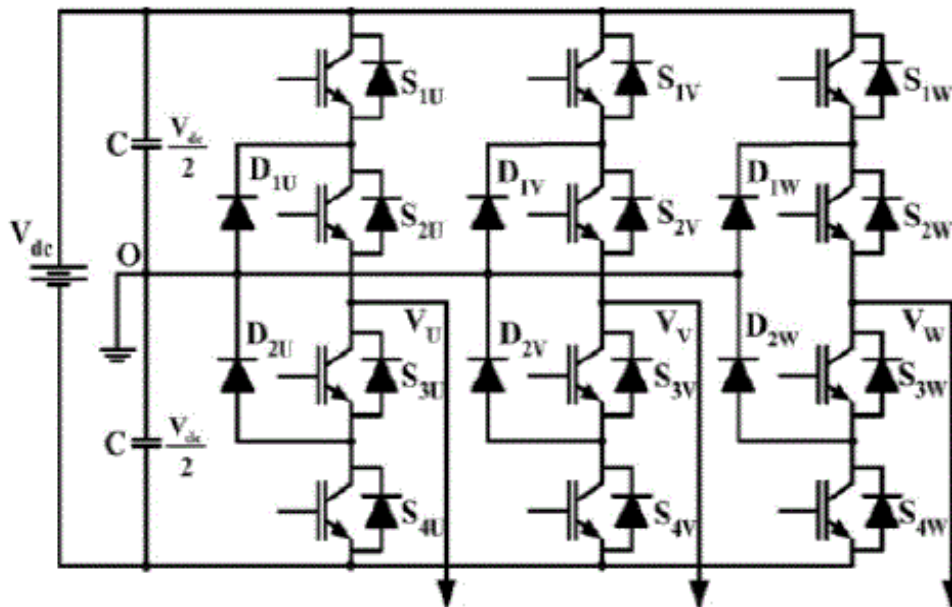

Fig 2. Three phase three level diode clamped inverter

The circuit diagram of a 3 level diode clamped inverter consists of two pairs of switches and two diodes. All switch pair's works in complimentary mode and the diodes used to provide access to mid-point voltage. The DC bus voltage is dividing into three voltage levels with the help of two series connections of DC capacitors, C1 and C2. With the help of the clamping diodes D1u and D2u the voltage stress across each switching device is partial to Vdc. It is supposed that the total dc link voltage is Vdc and mid-point is synchronized at half of the dc link voltage, the voltage across each capacitor is Vdc/2 (Vc1=Vc2=Vdc/2). In a three level diode clamped inverter, there are three different feasible switching states which apply the stair case voltage on output voltage relating to DC link capacitor voltage rate. At any time a set of two switches is on for a three-level inverter, and in a five-level inverter, a set of four switches is on at any given time and so on. Switching states of the three levels inverter are summarized in table-1.

Table 1 switching states in one leg of the 3 level diode clamped inverter

Switching state	Q1	Q2	Q3	Q4
+Vdc	1	1	0	0
0	0	1	1	0
-Vdc	0	0	1	1

The injected voltages are introduced into the distribution system through an injection transformer connected in series with the distribution feeder. The primary side of the injection transformer is connected in series to the distribution line, while the secondary side is connected to the DVR power circuit. Now three single phase transformers or one three phase transformer can be used for three phase DVR

To convert the three level PWM inverted pulse waveform into a sinusoidal waveform, low pass passive filters are used. In order to achieve this it is necessary to eliminate the higher order harmonic components during DC to AC conversion in voltage source inverter which will also distort the compensated output voltage. These filters which play a vital role can be placed either on high voltage side i.e. load side or on low voltage side i.e. inverter side of the injection transformers. We can avoid higher order harmonics from passing through the voltage transformer by placing the filters in the inverter side. Thus it also reduces the stress on the injection transformer. Comparing to conventional two level DVR, the Proposed DVR require only small size filter. This is reducing the cost of the DVR.



Various devices such as Flywheels, Lead acid batteries, Superconducting Magnetic energy storage (SMES) and Super-Capacitors can be used as energy storage devices. The main function of these energy storage units is to provide the desired real power during voltage sag.

The amount of active power generated by the energy storage device is a key factor, as it decides the compensation ability of DVR. Among all others, lead batteries are popular because of their high response during charging and discharging. So in this topology a lead acid battery is using.

IV. DVR CONTROL

The control of DVR is to inject the require voltage corresponding to the variation in load voltage. So that the voltage sags detection is needed. It is done by monitoring the peak supply voltage, monitoring the d- and q-axis components of the supply voltage, using a band pass filter or a phase-locked loop to each phase, applying Fourier transform to each phase, applying wavelet transform to each phase, and numerical matrix sag detection technique. More details for these techniques can be found in [7]. Monitoring of the d- and q-axis components of the supply voltage is used to detect the voltage sag in this paper.

Fig. 3 shows a control block of the DVR in which SRF theory is used for reference signal estimation. The voltages at PCC (vS) and at load terminal (vL) are sensed for deriving the VSC gate signals. The reference load voltage (VL*) is extracted using the derived unit vector [8]. Load voltages (VL_a,VL_b,VL_c) are converted to the rotating reference frame using abc-dqoconversion using Park’s transformation with unit vectors (sin□ , cos□ □) derived using a PLL (phase locked loop) as,

$$\begin{bmatrix} V_{Lq} \\ V_{Ld} \\ V_{L0} \end{bmatrix} = \frac{2}{3} \begin{bmatrix} \cos\theta & \cos(\theta - \frac{2\pi}{3}) & \cos(\theta + \frac{2\pi}{3}) \\ \sin\theta & \sin(\theta - \frac{2\pi}{3}) & \sin(\theta + \frac{2\pi}{3}) \\ \frac{1}{2} & \frac{1}{2} & \frac{1}{2} \end{bmatrix} \begin{bmatrix} V_{Laref} \\ V_{Lbref} \\ V_{Lcref} \end{bmatrix} \quad (1)$$

Similarly, reference load voltages (VL_a*,VL_b*,VL_c*) and voltages at PCC (VS) are also converted to the rotating reference frame. Then, the DVR voltages are obtained in the rotating reference frame as,

$$V_{Dd} = V_{Sd} - V_{Ld} \quad (2)$$

$$V_{Dq} = V_{Sq} - V_{Lq} \quad (3)$$

The reference DVR voltages are obtained in the rotating reference frame as

$$V_{Dd}^* = V_{Sd}^* - V_{Ld} \quad (4)$$

$$V_{Dq}^* = V_{Sq}^* - V_{Lq} \quad (5)$$

The error between the reference and actual DVR voltages in the rotating reference frame are regulated using two PI (Proportional-Integral) controllers. Reference DVR voltages in abc frame are obtained from a reverse Park’s transformation taking VD_d* from (4), VD_q* from (5), VD₀* as zero as

$$\begin{bmatrix} V_{dvra}^* \\ V_{dvrb}^* \\ V_{dvrc}^* \end{bmatrix} = \begin{bmatrix} \cos\theta & \sin\theta & 1 \\ \cos(\theta - \frac{2\pi}{3}) & \sin(\theta - \frac{2\pi}{3}) & 1 \\ \cos(\theta + \frac{2\pi}{3}) & \sin(\theta + \frac{2\pi}{3}) & 1 \end{bmatrix} \begin{bmatrix} V_{Laref} \\ V_{Lbref} \\ V_{Lcref} \end{bmatrix} \quad (6)$$

Reference DVR voltages (V_{dvra}*, V_{dvrb}*, V_{dvrc}*) and actual DVR voltages (V_{dvra}, V_{dvrb}, V_{dvrc}) are used to produce the reference signal for the PWM controller to generate gating pulses to a VSC of DVR. For a three level output the reference voltage is comparing with two repeating sequences to produce the PWM signal. In order to get a three level output voltage switch 1 and 3 are complement to each other, similarly switch 2 and 4 also complement to each other. The required switching signals are generated by comparing the DVR reference voltage with two triangular carrier waves. This PWM signal is given to the inverter switches as shown in fig.3

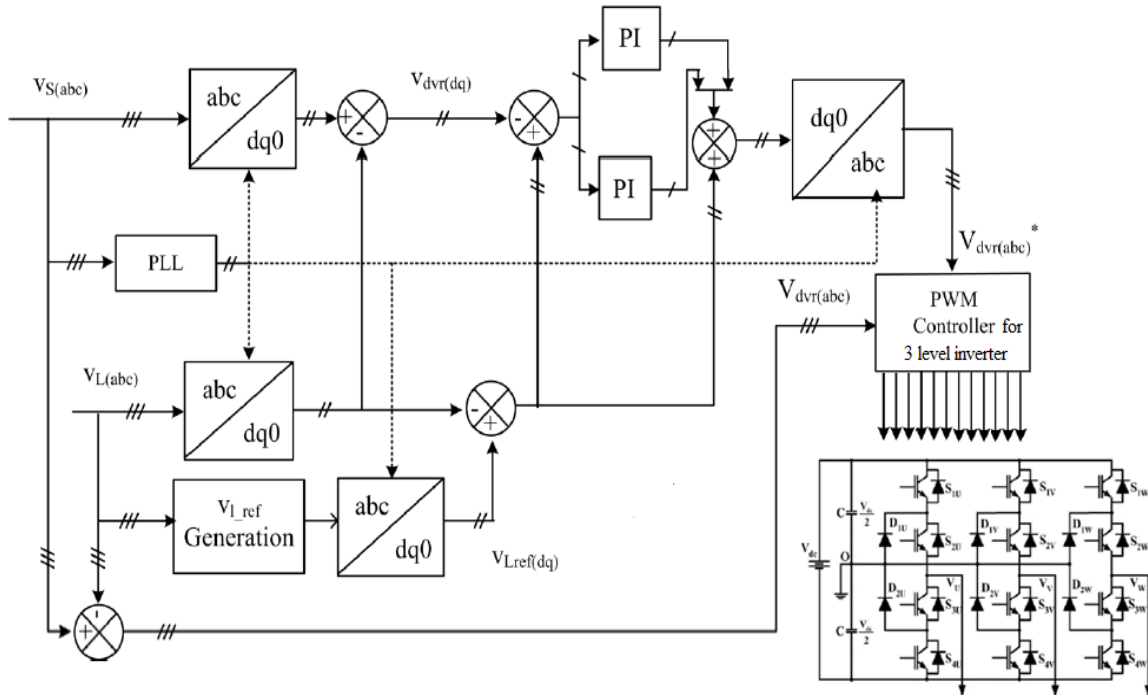

Fig 3. Control block of the three level Diode Clamped inverter based DVR which use the SRF method of control

V. RESULT AND DISCUSSION

The simulations are done in Matlab software. The diode clamped three level inverter based DVR and two level inverter based DVR are simulated and the results are analysed.

A. DVR with Three Level Diode Clamped inverter

The Simulations are done in Matlab Simulink. The Simulink diagram is shown fig 4. Voltage sag is created by using the programmable voltage source.

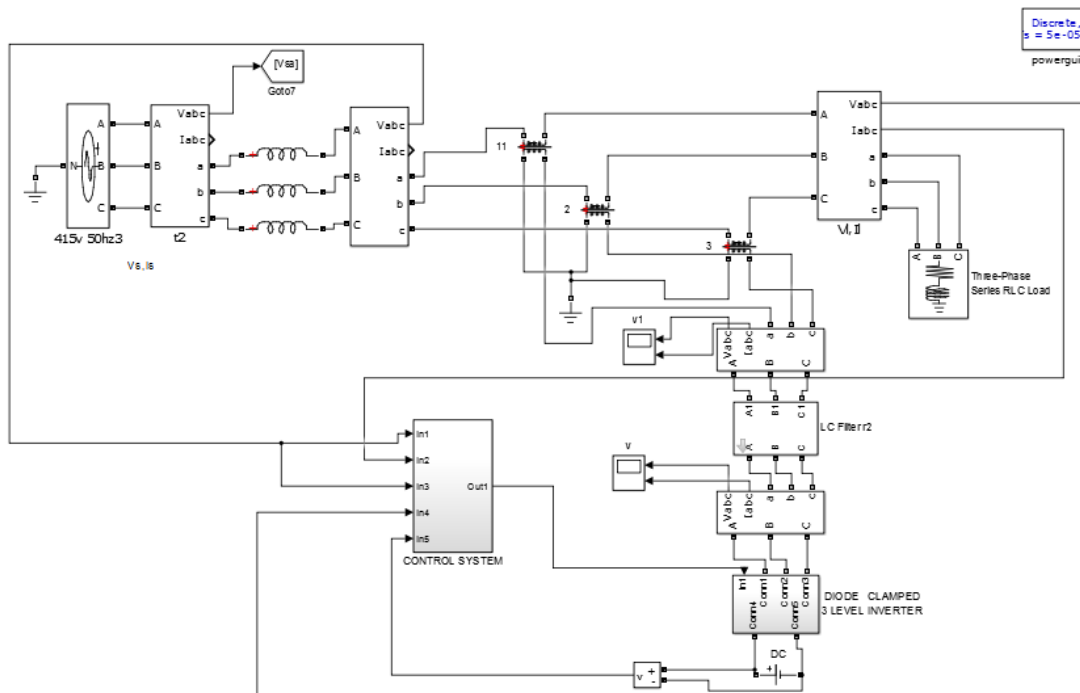

Fig.4 Simulink diagram of Diode Clamped Three level inverter based DVR



The input supply voltage is 230 V rms. For a 50 % sag, in supply voltage, DVR should inject a voltage of 115 V rms. For this a 200 V battery source is used. In phase injection is used here. The IGBT switches are used for Diode Clamped three level inverter. It inject a three level AC voltages in series such that the load voltage is maintained at rated value during sag. Linear transformers with 1:1 turn's ratio is used to inject the DVR voltage. The transformer rating is 10 KVA rms winding voltage are 240v rms. The load is 1000 watt active and 400 watt reactive.

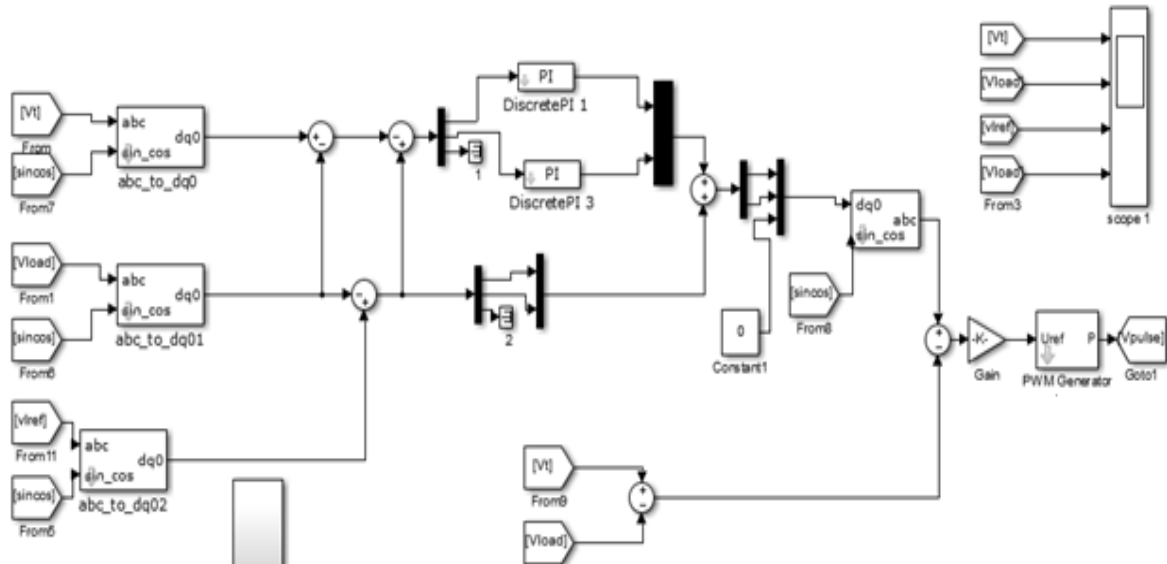

Fig 5. Matlab model of DVR control

The DVR is tested for 50% sag. Fig.6 (a) shows the supply voltage with 50% sag from the instant 0.2 to 0.3 and fig.6 (b) shows the load reference voltage and fig 6(c) is DVR reference voltage. The load reference voltage is the required load voltage after compensation and it is 230 V rms. Fig 7(a) shows the DVR injected voltage, which is a three level inverter voltage and fig.7 (b) show the actual DVR injected voltage with LC filter. Filter is used to eliminate the harmonics in the converter output voltage. Fig 7(c) is the load voltage after compensation and fig.7 (d) is the load current. From the figure we can see that the DVR injecting a voltage proportional to the sag in order to retain the load voltage at the instant from 0.2 to 0.3.

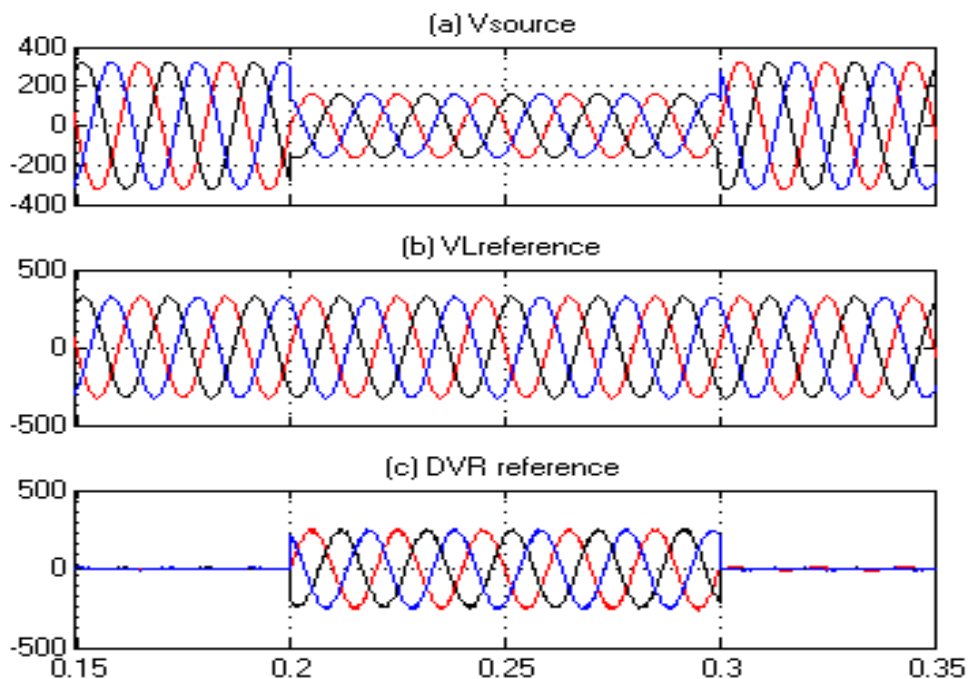

Fig .6 (a) source voltage (b) load reference voltage (c) DVR reference voltage

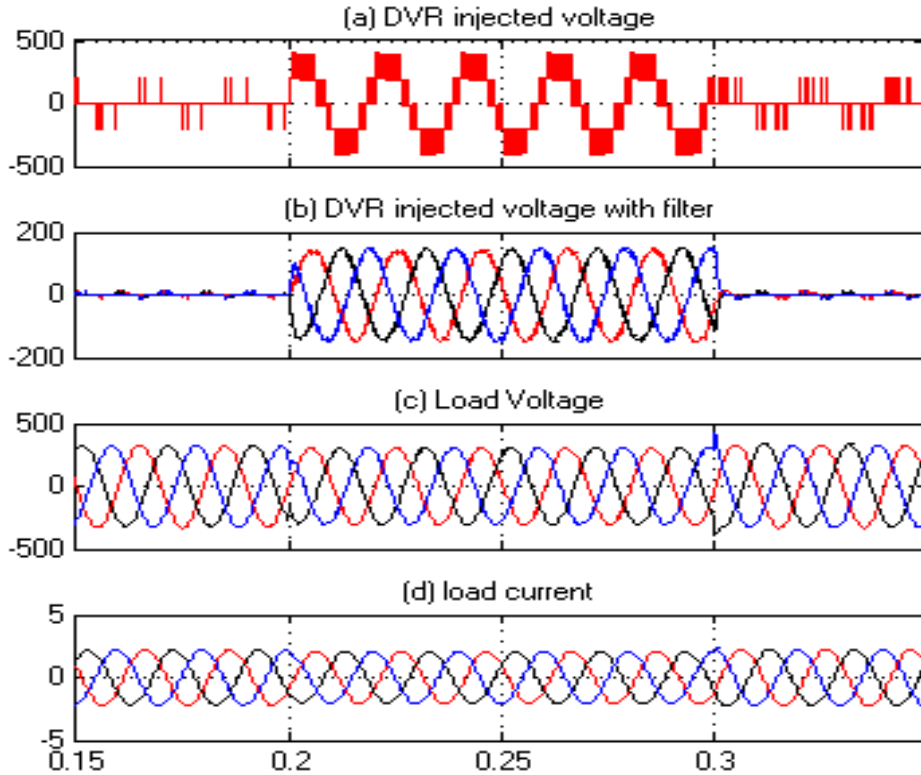

Fig.7 (a) DVR injected voltage (b) DVR injected voltage with filter (c) load voltage (d) load current

Fig.8 shows the harmonic spectrum of the load voltage. The THD is found to be 3.57% which is in the acceptable limit. Thus the three level inverter improved the harmonic performance of the DVR.

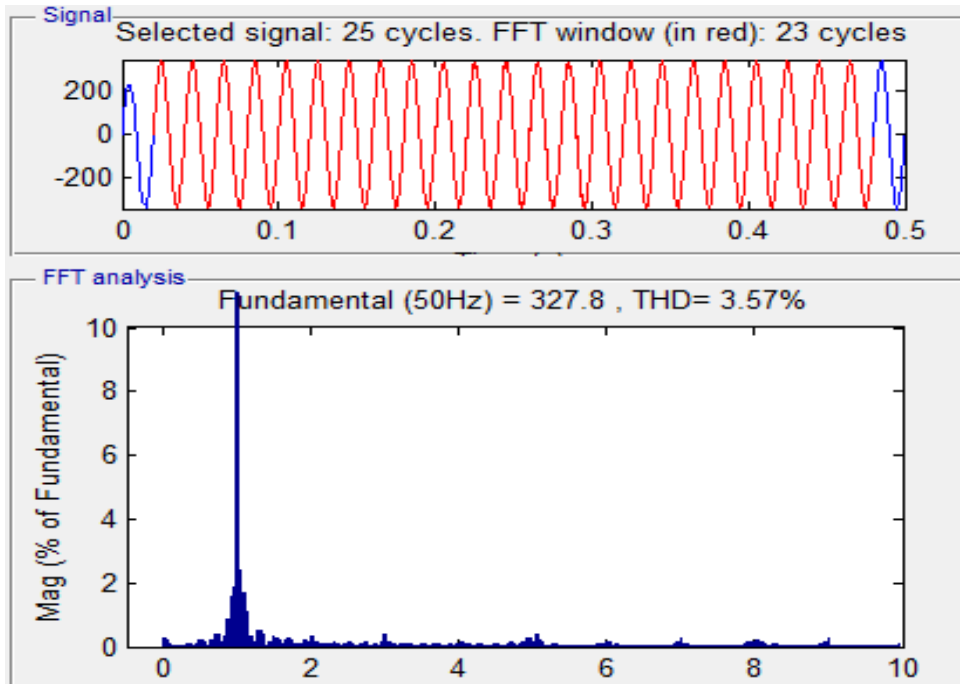

Fig. 8 harmonic spectrum of load voltage

B. DVR with Two Level inverter

In order to compare the performance of a Three Level Diode Clamped inverter DVR, a two level inverter based DVR is simulated. From the simulation result harmonic performance of the two DVR is analysed. The DVR is tested for 50%



sag. Fig.9(a) shows the supply voltage with 50% sag from the instant 0.2 to 0.3 and fig.9(b) shows the load reference voltage. The load reference voltage is the required load voltage after compensation, it is 230 V rms. Fig 10(a) shows the DVR reference voltage and fig.10(b) show the actual DVR injected voltage with LC filter. Filter is used to eliminate the harmonics in the converter output voltage. The load voltage is maintained to rated value by series injection of desired voltage corresponding to the sag.

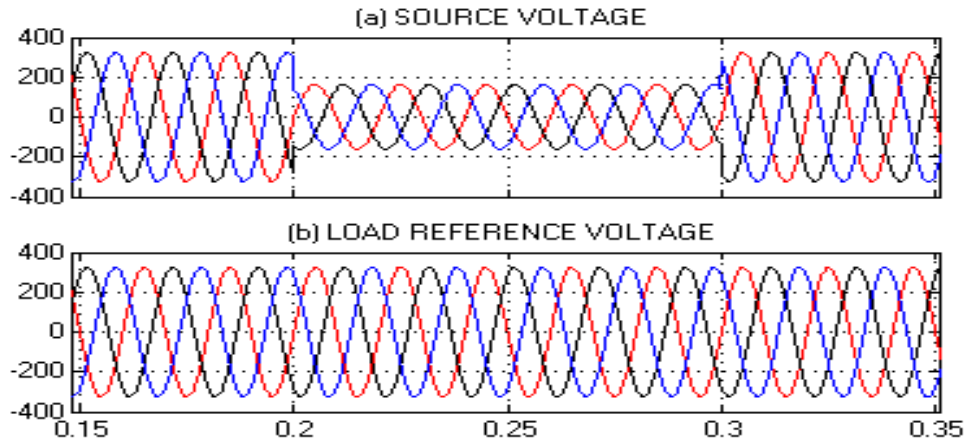

Fig 9. (a) supply voltage(V_s) , (b) load voltage (V_L)

Fig.11(a) shows the load voltage after compensation. The sag in the supply voltage is restored by the DVR. Fig.11(b) shows the load current after compensation. Fig.12 shows the switching pulses generated by the PWM generator.

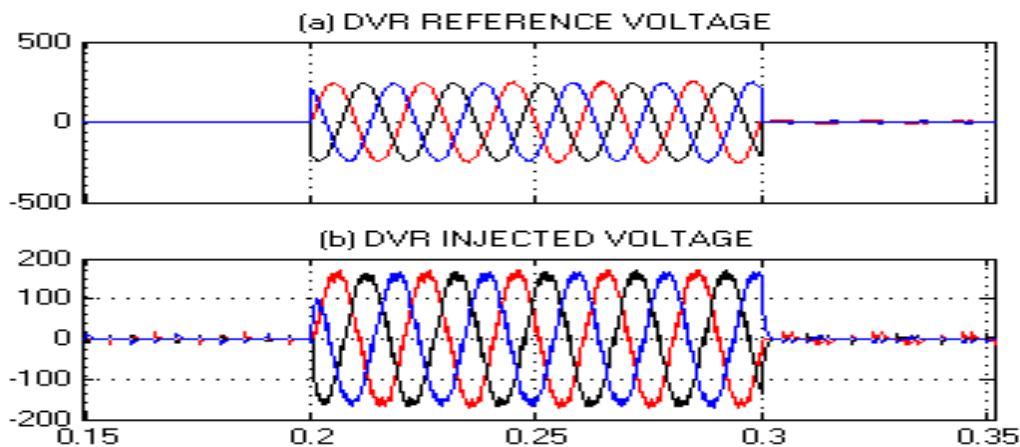

Fig 10 (a) compensator reference voltage(V_C^*), (b) DVR injected voltage

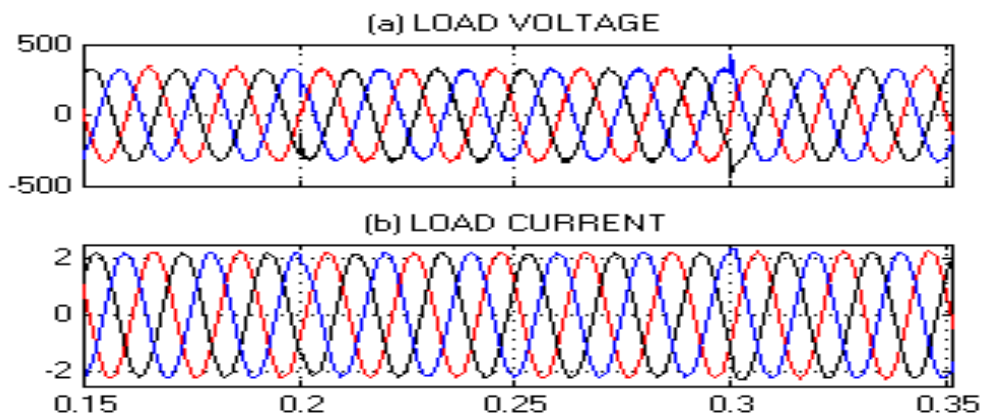

Fig 11. (a) load voltage (V_L), (b) load current



SWITCHING PULSES

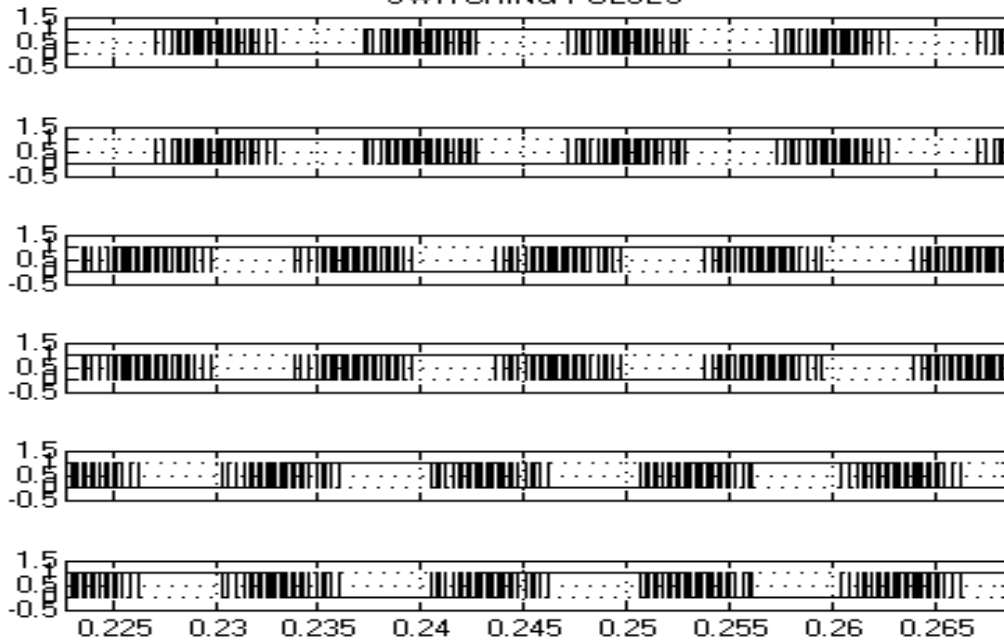

Fig 12. Switching signal for the inverter

Fig.13 shows the harmonic spectrum of the load voltage. It is found that the THD is about 4.36 % and is in the acceptable limit. From the figure we can see that the higher order harmonics are not present. For a three level inverter THD is about 3.57%. thus the THD is found improving by increasing the level of the inverter. So comparing to two level inverter based DVR, the filter size is also reduced drastically for a three level Diode Clamped inverter based DVR. So the cost of the three level DVR is low.

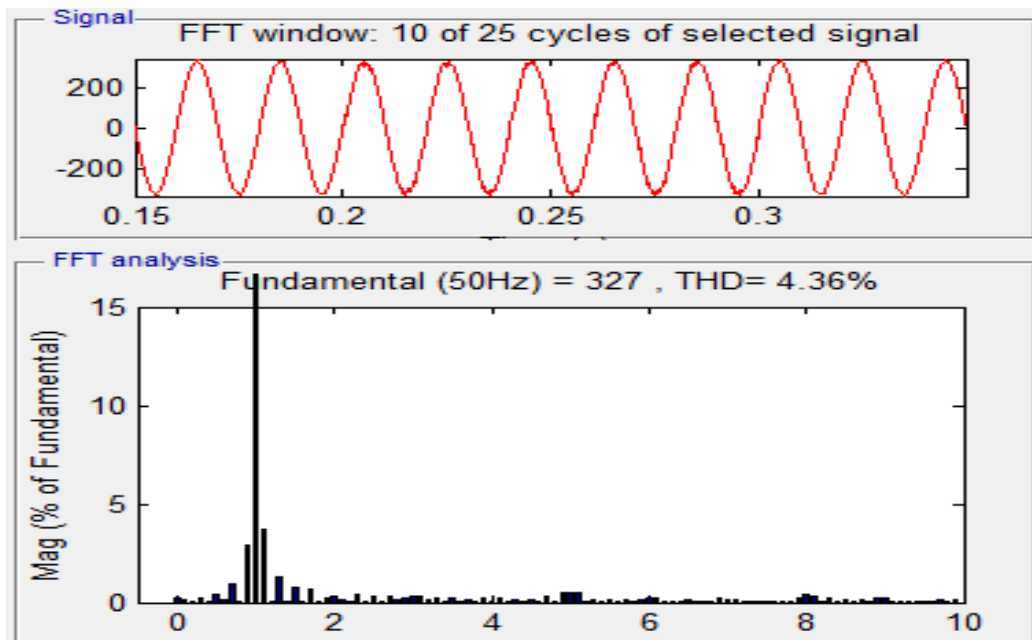

Fig.13 harmonic spectrum of load voltage

The simulations are done for 30 % voltage sag also. The following figures show the DVR operation for a sag of 30%. Fig. 14(a) shows the supply voltage with 30% sag for a time interval of 0.2 to 0.3 second. Fig.14(b) shows the load reference voltage and fig.14(c) shows the DVR reference voltage. Fig 15(a) shows the DVR injected voltage in order to maintain the load voltage rated. Fig 15(b) shows the load voltage after compensation. Thus by proper series injection of voltage maintain the desired load voltage. Fig 15(c) shows the load current.

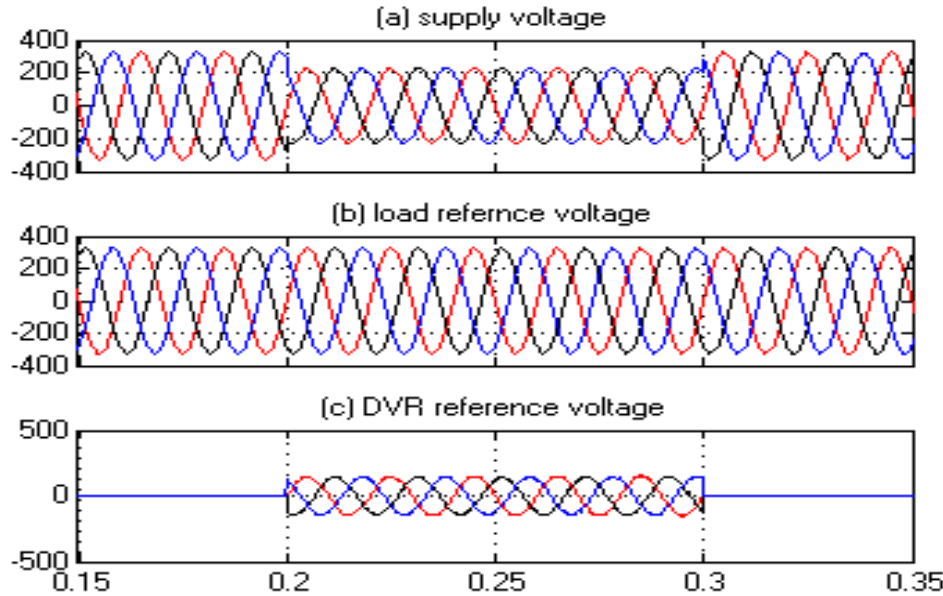

Fig 14 (a) supply voltage with 30 % sag. (b) Load reference voltage. (c) DVR reference voltage

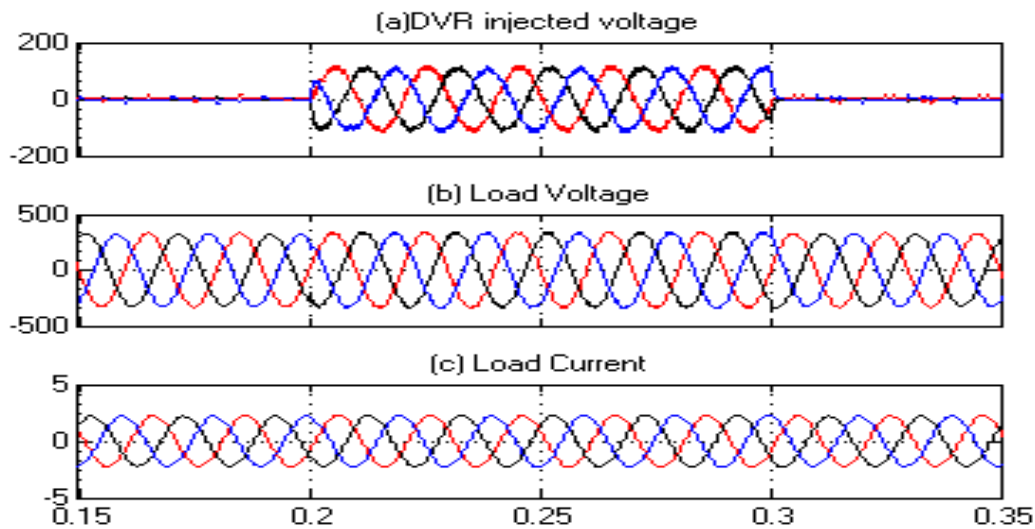

Fig .15 (a) DVR injected voltage. (b) Load voltage after compensation (c) Load current

VI. CONCLUSION

The three level inverter based DVR has high voltage blocking capability, reduced switching losses, better harmonic performance. The Diode Clamped multilevel inverter based DVR has less components comparing to other topology, also it has extended sag compensation capability. This paper deals with the control and working of a Diode Clamped multilevel inverter based DVR. The SRF control is used for the DVR control and SPWM is used for inverter switching pulse generation. The simulations of a two level DVR and three level DVR is done in Matlab Simulink and the result is analysed. The load voltage THD of the two level inverter based DVR is about 4.36% and the THD of three level inverter based DVR is 3.57%. Thus the harmonic performance of the multilevel inverter based DVR is better than that of two level DVR. By employing the three level inverter the filter size is reduced. Thus the cost of the DVR is reduced.

REFERENCES

[1] Voltage Characteristics of Electricity Supplied by Public Distribution Systems, Ver. BS EN 50160:2007, 2000
[2] A Ghosh and G Ledwich, "Power Quality Improvement Using Custom Power Devices", IEEE Press, 2001.



- [3] N. H. Woodley, L. Morgan, and A. Sundaram, "Experience With An Inverter-Based Dynamic Voltage Restorer," IEEE Transactions on Power Electronics, vol. 14, no. 3, pp. 1181–1186, Jul. 1999.
- [4] A. Campbell and R. McHattie, "Backfilling TheSinewave. A Dynamic Voltage Restorer Case Study," IEEE Transaction on Industrial Electronics, vol. 13, no. 3, pp. 153–158, Jun. 1999.
- [5] C. Zhan, V. K. Ramachandaramurthy, A. Arulampalam, C. Fitzer, S. Kromlidis, M. Barnes, and N. Jenkins, "Dynamic Voltage Restorer Based On Voltage-Space-Vector PWM Control," IEEE Transaction on Industrial Application, vol. 37, no. 6, pp. 1855–1863, Nov. 2001.
- [6] C. Fitzer, A. Arulampalam, M. Barnes, and R. Zurowski, "Mitigation of Saturation in Dynamic Voltage Restorer Connection Transformers," IEEE Transaction on Power Electronics, vol. 17, no. 6, pp. 1058–1066, Nov. 2002.
- [7] E. Babaei, M. F. Kangarlu, and M. Sabahi, "Mitigation of Voltage Disturbances Using Dynamic Voltage Restorer Based on Direct Converters," IEEE Transaction on Power Delivery, vol. 25, no. 4, pp. 2676–2683, Oct. 2010.
- [8] Wang, B., Venkataramanan, G., Illindala, M.: "Operation and Control of A Dynamic Voltage Restorer Using Transformer Coupled H-Bridge Converters", IEEE Transactions on Power Electronics, vol. 13, no. 8, pp. 1666–1671 Aug. 2006
- [9] P. Lezana, J. Rodriguez, and D. A. Oyarzun, "Cascaded Multilevel Inverter With Regeneration Capability And Reduced Number of Switches," IEEE Transactions on Industrial Electronics, vol. 55, no. 3, pp. 1059–1066, Mar. 2008
- [10] S.A. González, M.I. Valla, C.F. Christiansen, "5-level Cascade Asymmetric Multilevel Converter", IEEE Transaction on Power Delivery, Vol. 3, pp. 120–128, Jul. 2010
- [11] Y. Liang and C. O. Nwankpa, "A Power-Line Conditioner Based On Flying-Capacitor Multilevel Voltage-Source Converter With Phase-Shift PWM," IEEE Transactions on Industrial Application, vol. 36, no. 4, pp. 965–971, Jul. 2000
- [12] Al-Hadidi, H.K., Gole, A.M., Jacobson, D.A.: "A Novel Configuration For A Cascade Inverter-Based Dynamic Voltage Restorer With Reduced Energy Storage Requirements" IEEE Transaction on Power Delivery. 2008, 23, (2), pp. 881–888, Jun. 2011
- [13] A. K. Gupta and A. M. Khambadkone, "A Space Vector PWM Scheme For Diode Clamped Multilevel Inverters," IEEE Transaction on Industrial Electronics, vol. 53, no. 5, pp. 1631–1639, Oct. 2006
- [14] M. Vilathgamuwa, A. A. D. RanjithPerera, and S. S. Choi, "Performance Improvement Of The Dynamic Voltage Restorer With Closed-Loop Load Voltage And Current Mode Control," IEEE Transaction on Power Electronics, vol. 17, no. 5, pp. 824–834, Sep. 2002.
- [15] E. C. Aeloiza, P. N. Enjeti, L. A. Morán, O. C. Montero Hernandez, and S. Kim, "Analysis and Design of A New Voltage Sag Compensator For Critical Loads in Electrical Power Distribution Systems," IEEE Transactions on Industrial Application, vol. 39, no. 4, pp. 1143–1150, Jul. 2003

BIOGRAPHIES

MithunK Completed B.Tech in electrical and electronics engineering from Kannur University. Pursuing M.Tech in power electronics and drives from Govt. College of Engineering Kannur.

Dr. Jayaprakash P He received his B. Tech. (Electrical and electronics Engg) from the University of Calicut, Kerala in 1996 and the M. Tech. and PhD from Indian Institute of Technology, Delhi in 2003 and 2009 respectively.