

# Human Detection System Using Drone For Earthquake Rescue Operation

**A. Shobika<sup>1</sup>, N. Thenkuzhali<sup>2</sup>, S. Suganya<sup>3</sup>, G.R. Nivedha<sup>4</sup>, R.Hiemaja<sup>5</sup>**

UG Scholar, Department of Instrumentation and Control Engineering,  
Sri Manakula Vinayagar Engineering College, Puducherry<sup>1,2,3,4</sup>

Assistant Professor, Department of Instrumentation and Control Engineering,  
Sri Manakula Vinayagar Engineering College, Puducherry<sup>5</sup>

**Abstract:** Many areas of the world get affected by natural calamity. Disasters are unstoppable and leave behind a great loss of life. Disasters like earthquake, floods, etc. cause mass destruction and often lives get buried or trapped in debris. In such situations detection by rescue workers becomes time consuming and due to the vast area that gets affected it becomes more difficult. In this system, we are proposing a human detection quad-copter which can detect alive humans in debris so that timely help can be made available to the victims. The proposed alive human being detection system contains Passive Infrared sensor (PIR) which gives the information about the presence of alive human body. Radio Frequency Technology is used to control the quad-copter. ATMEGA8A microcontroller will give an alerting message to the rescue operator of the affected sites and they will give proper rescue to the affected victims. In disaster sites, it will be a great help to rescuers in detection of more alive human beings at the proper time. This system is also user friendly, economical, semi-autonomous and efficient for detection.

**Keywords:** PIR sensor, ATMEGA8A microcontroller, quad-copter, Brushless DC motor, Buzzer, RF transmitter and receiver.

## I. INTRODUCTION

A timely rescue can only save the people who are buried and wounded due to a disaster. In such situations, rescue system must take fast decisions under pressure, and try to get victims to safe location at their own risk. The rescue system must collect the location information and status of victims as quickly as possible so that medication and fire-fighters can enter the disaster-prone area and save people. All these works are performed mostly in very dangerous and risky situations by human and trained dogs. Detection by rescue workers becomes time consuming and due to the vast area, that gets affected it becomes more difficult. The project proposes a drone or quad-copter that fly in a disastrous area and helps in identifying the live people and rescue operations. A Passive Infrared sensor is used in the project which emits infrared rays to detect humans. As live human body emits thermal radiation it is received and manipulated by the PIR sensor to detect humans. Once the people are located it immediately gives audio alert to the authorities so that help can reach the live person very fast. This PIR sensor is placed on a moving all direction quad-copter that can fly in the earthquake prone areas. The quad-copter is driven on a brushless dc motor for increased torque. Detection by rescue workers is time consuming; therefore, here we are using the quad-copter for earthquake rescue operation.

## II. EXISTING SYSTEM

In the existing system the PIR sensor is placed on a all direction moving robot that can maneuver in the earthquake prone areas. The robot is driven on a geared dc motor for increased torque and low speed and stepper motor for increased turning accuracy hence the precise control of position is monitored. The robot consists of a three-wheel geared drive with DC motors attached to perform forward and reverse movement and this serves the purpose of detecting the buried people through transmitting and receiving the PIR rays. The main drawback of the system is that it is more prone to get struck under the deformed structures and also it is not cost efficiency.

## III. PROPOSED SYSTEM

In order to overcome the above said drawbacks here is a proposal for a system which replaces the DC driven robot by a flyable quadcopter. The project proposes a flyable quadcopter that moves in the disaster-prone area and helps in identifying the live people those are injured and performs rescue system operations. Hence due to the timely detection of victim's precious life can be saved without the help of large number of rescue operators.

**IV. HARDWARE COMPONENTS**

- ATMEGA8A microcontroller
- PIR sensor
- Flight controller
- RF transmitter and receiver
- Electronic speed controller
- Brushless DC motor
- Propeller
- Buzzer
- Lithium Polymer Battery
- Quad copter Frame

**V. BLOCK DIAGRAM OF PROPOSED SYSTEM**

The PIR sensor which is fixed with the quad copter detects the body temperature of the human buried under the earth.

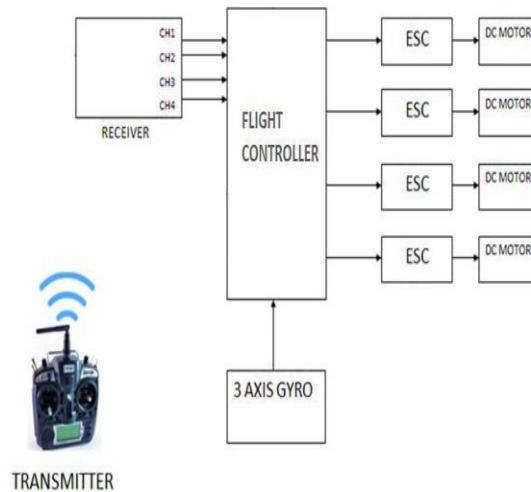

Figure 1. Block diagram of drone

The block diagram of quad-copter or drone consists of a RF transmitter and a receiver which is used to transfer and receive RF signals at a frequency of about 2.4GHz for the movement of drone. In the transmitting section, Radio transmitter uses radio signal to remotely control quad-copter in wireless way, the commands given by transmitter are received by a radio receiver connected to flight controller. The four channels in transmitter determine the actions of aircraft controlled by the operator that includes pitch. Roll, throttle and yaw. The receiver side consists of RF receiver, flight controller, ESC, BL-DC motor. Once the signal received from the transmitter, RF receiver sends the signal to the microcontroller and ESCs receive command from micro controller circuit board and it converts the PWM signal received from flight controller and then drives the brush less DC motor by providing required electrical power. Based on the command given by the transmitter, a BL-DC motor is used to move the quad-copter in left, right and forward and backward directions, upward and downward directions. A 3 axis gyro-sensor is attached with the flight controller for the stability purpose of drone during its flight mode.

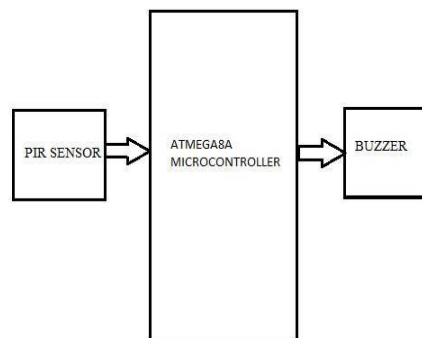

Figure 2. Block diagram of PIR sensor

The block diagram of human detection system consists of a Passive Infrared Sensor, Atmega8A microcontroller, and a buzzer as an alarming device. The Passive Infrared sensor used in the project which emits infrared rays to detect humans. As live human body emits thermal radiation it is received and manipulated by the PIR sensor to detect humans. Once the alive human being is located in debris, it immediately sends the signal to the microcontroller and this microcontroller will digitize the signal and it enables the buzzer which is connected at the output pin of microcontroller. The buzzer needs 100mA of current to generate the alarming sound, so there is a need of resistor and transistor circuit to amplify the current from 30mA to 100mA to the microcontroller.

### ATMEGA8A MICROCONTROLLER

The ATmega8A is a low-power CMOS 8-bit microcontroller based on the AVR enhanced RISC architecture. By executing powerful instructions in a single clock cycle, the ATmega8A achieves throughputs close to 1 MIPS per MHz's. This empowers system designed to optimize the device for power consumption versus processing speed.

**PIR SENSOR.** A Passive Infra-Red sensor (PIR sensor) is an electronic device which measures infrared light radiating from objects in its field of view. Apparent motion is detected when an infrared source with one temperature, such as a human, passes in front of an infrared source with another temperature, such as a wall.

**Design:** Infrared radiation enters through the front of the sensor, known as the sensor face. At the core of a PIR is a solid-state sensor or set of sensors, made from approximately 1/4 inches square of natural or artificial pyro electric materials, usually in the form of a thin film, out of gallium nitride (GaN), caesium nitrate (CsNO<sub>3</sub>), polyvinyl fluorides, derivatives of phenyl pyrazine, and cobalt phthalocyanine. Lithium tantalate (LiTaO<sub>3</sub>) is a crystal exhibiting both piezoelectric and pyroelectric properties.



Figure 3. PIR sensor

Features:

- Single bit output
- Jumper selects single or continuous trigger output
- Mode, 3-pin SIP header ready for breadboard or through whole Project.
- Small size makes it easy to conceal
- Compatible with BASIC Stamp, Propeller, and many other microcontrollers.

### FLIGHT CONTROLLER

Flight controller used in quad-copter is the main functioning body of our aircraft. It's a circuit board that receive different commands sent by user to control speed of motors so that quad-copter could be stable in fly mode. The quad-copter flies and moves by changing the RPMs of each propeller. So when one moves a stick on the transmitter it sends the signal to the controller via receiver, this command needs to be converted into the proper commands to operate each of the four motors on the quad-copter. This is done by the flight control system. The purpose of the flight computer is to simplify the coordination of the control of all four propellers needed to make the drone fly. The flight controller has the ability to connect to several other devices and sensors.



Figure 4. Flight controller

## RF TRANSMITTER AND RECEIVER

The radio frequency transmitters (RF) transmit the radio frequency signals and the radio frequency Receivers (RF) receives the radio frequency signals and demodulates it. Radio transmitter uses radio signal to remotely control quadcopter in wireless way, the commands given by transmitter are received by a radio receiver connected to flight controller.



Figure 5. RF transmitter and receiver

The number of channels in transmitter determine how many actions of aircraft can be controlled by pilot. Minimum of four channels are needed to control a quad copter (which includes pitch, Roll, throttle, yaw). RF receiver operates on 2.4GHz of radio frequency.

## ELECTRONIC SPEED CONTROLLER

Electronic speed controller (ESC) receive command from micro controller circuit board and further give command to the motors for rotation. Four 30A ESCs (electronic speed controllers) are used in proposed Quadcopter. It converts the PWM signal received from flight controller or radio receiver and then drives the brush less motor by providing required electrical power. ESC is an electric circuit that control the speed and direction of electric motor by varying the magnetic forces created by the windings and magnets within the motor.

## BRUSHLESS DC MOTOR

BL-DC motor also known as electronically commuted motors (i.e. ECMs motors). BLDC motor are synchronous motor powered by DC electricity. Rated in KV, where it rotates 1000rpm per 1 volt supplied to it (if its rating is 1 KV). It offers several advantages over brushed DC motors like more reliability, low noise, reduction in EM Interference (EMI), high torque per watt etc.



Figure 7. BLDC motor

## PROPELLER

A propeller is a type of fan that transmits power by converting rotational motion into thrust. A pressure difference is produced between the forward and rear surfaces of the airfoil-shaped blade, and a fluid (such as air or water) is accelerated behind the blade.



Figure 8. Propeller

## GYROSCOPE

Quad copter requires flight stability sensors that stabilize quad copter during its flight mode. Gyroscope is low power sensor with a sensing element and an IC interface (able to provide the measured angular rate to users through digital interface I2C/SPI).

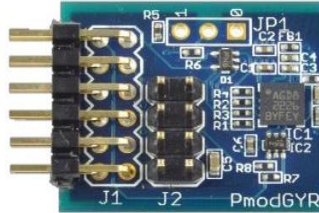

Figure 9. 3 axis gyroscope sensor

## LITHIUM POLYMER BATTERY

Li-Po (Lithium Polymer battery) is a rechargeable battery of lithium ion technology. They provide higher specific energy and are being used where weight is a critical factor. It also provides high voltage and long run time as they hold huge power in small package and have high discharge rates required to meet the need of powering quadcopters.

## FRAME OR CHASSIS

The plastic polymer frame is used and it is best suited for the propellers and payloads which has to be lifted along with quadcopter. Quad copter requires a frame to host a 4 BLDC motors, 4 ESCs.



## BUZZER

A buzzer is an audio signalling device. In a buzzer, an electromagnet is used to operate a self-interrupting circuit. When the circuit is closed, the electromagnet is magnetized so it pulls up on the contact arm. This breaks the doorbell circuit, which shuts off the electromagnet. The arm falls down, closing the circuit again and the process repeats. The buzzing noise one hears is the sound of the rapidly moving arm hitting the magnet and the stationary contact dozens of times a second.



Figure 9. buzzer

## VII.ADVANTAGES

- The proposed system is an effective and a safe system to ensure that there are no humans left behind in a rescue operation.
- In the existing system, Human detection robot is not very effective and it is not able to identify the people getting trapped on the water and the proposed system is very helpful for the detection of human in all kind of natural calamities.
- The system is used to handle the quad-copter by everyone and does not need an expert to handle.
- The system is friendly, economical, efficient, semi-autonomous and very simple to use.

VI. FLOW CHART OF PROPOSED SYSTEM

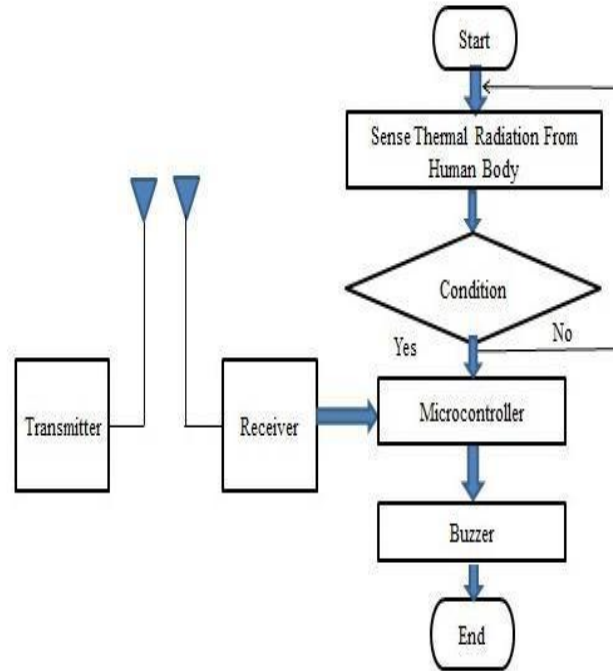

Figure 10. flow chart of proposed system

VIII. RESULT

In order to simulate the quad-copter, a remote was designed and the control was with the rescue team. This helped the rescuers to move the quad-copter in various directions. This quad-copter consists of a PIR Sensor and a camera fitted to it and when the sensor detects the alive human beings, it will produce the buzzer sound. This quad-copter is set ON with the help of battery connected to the drone. Once this starts, the remote control with four keys is used to move this drone. Among the four keys, two are used to move this quad-copter in forward, backward, upward and downward direction and other two are used to move in left, right and around 360 degrees. The PIR sensor triggers and starts sensing. The PIR detection angle is 120 degrees around it. Figure 11 represents the output of PIR sensor, when any Human being is found alive around its detection angle. It will alert the rescue operator with the help of the buzzer.



Figure 11. prototype of proposed system

**REFERENCES**

- [1]. B.Uthra[1], D.Adchiya[2], K.Anupriya[3], “Live Human Detection System for Earthquake Rescue Operation”, Journal Of Computation in Bioscience and Engineering , Volume 2, Issue 3, September 11, 2015.
- [2]. Saravana Kumar K [1] , Priscilla P[2], Germiya K Jose , Balagopal G[4], ” Human Detection Robot using PIR Sensors”, International Journal of Science, Engineering and Technology Research (IJSETR) Volume 4, Issue 3, March 2015.
- [3]. Mittika Ukey[1], Sonam Gupta[2], Bhagyashali Masane[3], Chanchal V.Dahat[4], “Alive Human Detection Robot in Rescue Operation”,International Journal of Advanced Research in Electronics and Communication Engineering (IJARECE) Volume 5, Issue 3, March 2016.
- [4]. Asha Gupta [1], Nidhee Panchal[2], Dhruvi Desai[3], Divya Dangi [4], “Live Human Detection Robot”,International Journal for Innovative Research in Science and Technology (IJIRST)Volume 1,Issue 6,November 2014.
- [5]. Rahul Krishna K [1], Meera A [2], Nikhil Mathew [3], “Wireless Human Detection Robot”, International Journal for Research in Applied Science and Engineering Technology (IJASET) Volume 5, Issue 4, April 2017.
- [6]. Seiji Miyama [1], Michita Imai [2], and Yuichiro Anzai, “Rescue Robot under Disaster Situation: Position Acquisition with Omni-directional Sensor”,International Robots and System (IROS) Volume 3,October. 2003.
- [7]. Trupti B. Bhondve [1], Prof.R.Satyanarayan [2] , Prof. Moresh Mukhedkar [3], “Mobile Rescue Robot for Human Body Detection in Rescue Operation of Disaster”,International Journal of Advanced Research in Electrical,Electronics and Instrumentation Engineering (IJAREEIE), Volume 3, Issue 6, June 2014.
- [8]. Hardeep Pal Sharma [1],Guna sekar.C.H [2], S.Adithya Kumar [3], “Live Human Detecting Robot for Earthquake Rescue Operation ”, International Journal of Business Intelligents ISSN, Volume 02, Issue 01, June 2013.
- [9]. Sandeep Bhatia [1], Hardeep Singh Dhillon [2],Nitin Kumar [3], “Alive Human Body Detection system using anAutonomous Mobile Rescue Robot”,IEEE Transactions ,Volume 11,Issue 2, March 2011.
- [10]. Steve Burion [1], “Human Detection for Robotic Urban Search and Rescue”, Info science database of the publications and research reports, February 2004.