

# Auto Metro Train Shuttle between Two Stations

Bharathi K V<sup>1</sup>, Divya<sup>2</sup>, Raseeda S<sup>3</sup>, Tejaswini N S<sup>4</sup>, Dr.Shankaralingappa C B<sup>5</sup>

Student, 8<sup>th</sup> Semester, Dept, of EEE, Dr AIT, Bangalore, India<sup>1,2,3,4</sup>

Professor, Dept, of EEE, Dr AIT, Bangalore, India<sup>5</sup>

**Abstract:** The paper is to illustrate the technology of automatic train control and operation used in metro train movements which are used in most of the developed countries. This train is equipped with a controller that enables the automatic stopping of the train from station to station. This paper presents the development process of a prototype driverless train, implemented using an ARM microcontroller.

**Keywords:** ARM7 (LPC 2148), Battery, DC Motor, IR Sensors, LCD display, Motor Driver.

## INTRODUCTION

Nowadays the accident of trains are increasing day by day, of these major accidents are occurring due to human faults. A man can do a mistake but a programmed processor has a less chance of doing error. Many researchers have done the work to reduce such accidents by automation.

Many researchers have done the work to reduce such accidents by Automation:

- The wide development of Automated Fare Collection (AFC) systems opens up a new opportunity. However, only each trips tap-in and tap-out time stamps and stations can be directly obtained from AFC system records; the train and route chosen by a passenger are unknown, information necessary to solve our problem. In this paper, we present an approach to calculate the probability of route choices for an OD pair with multiple routes in a complex metro network. From “IEEE transaction on intelligent transport”
- The main aim of this paper is to illustrate the technology used in metro train movements which are used in most of the developed countries. From “ International conference on science and Engineering for sustainable Development”

This paper is designed to demonstrate the technology used in metro train movements which are used in most of the developed countries. In this paper ARM 7 has been used as CPU. Whenever the train arrives at the station it stops automatically, as sensed by an IR sensor. The door then closes and the train starts after a prescribed time set in the controller by the program. The passenger counts and the stations are displayed on a LCD display interfaced to the ARM 7. The movement of the train is controlled by a motor driver IC interfaced to the ARM 7. The train incorporates a buzzer to alert the passengers before closing the door and also warn them before starting.

## BLOCK DIAGRAM

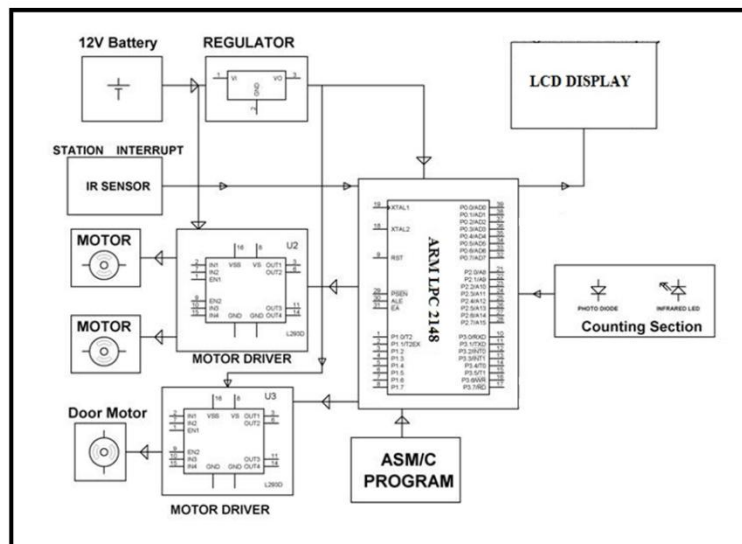

### WORKING

This train is equipped with a controller that enables the automatic running of the train from one station to another. This proposed system is an autonomous train and it eliminates the need of any driver. Thus, any human error is ruled out. In this paper ARM 7 has been used as CPU. Whenever the train arrives at the station it stops automatically, as sensed by an IR sensor. Then the door opens automatically so that the passengers can go inside the train. It is equipped with a passenger counting section, which counts the number of passengers leaving and entering the train. There should be a passenger limit for example 10 passengers is the limit- after 10 passengers getting into the train the doors will be automatically closed.

The door then closes and the train starts after a prescribed time (there will be a time set already as to how many minutes the train will stop at every station) set in the controller by the program. The passenger counts and the stations are displayed on a LCD display interfaced to the ARM 7. The movement of the train is controlled by a motor driver IC interfaced to the ARM 7. The train incorporates a buzzer to alert the passengers before closing the door and also warn them before starting. As the train reaches the destination the process repeats thus achieving the desired operation. Further the paper can be enhanced by making this system more advanced by displaying the status of the train over a larger display unit for the convenience of the passengers. The status of the train consists of the parameters like, expected arrival and departure time etc.

### FLOW CHART

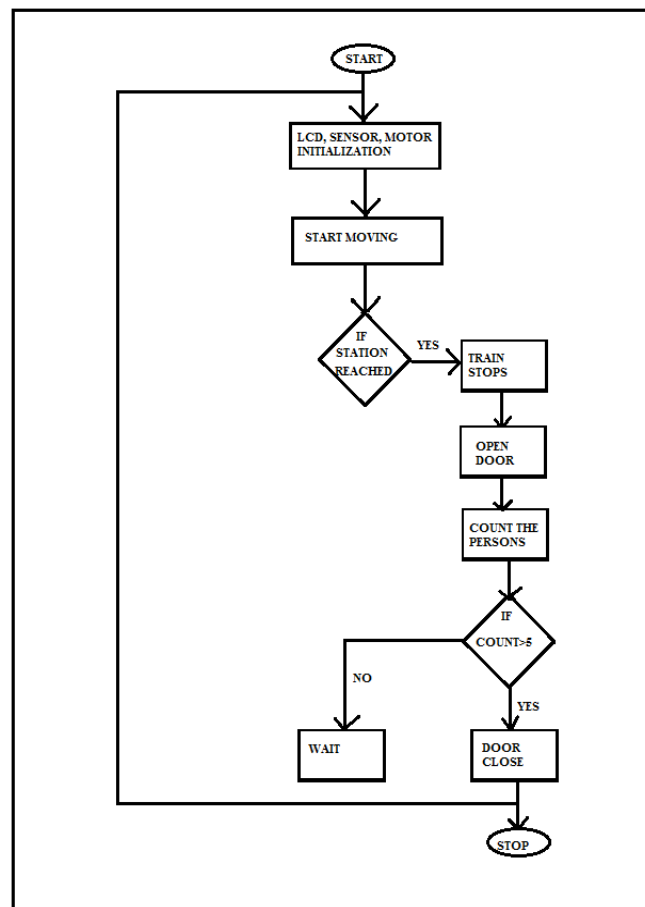

### APPLICATIONS

- This paper is useful in developing countries and this paper has a bright future as it is been used in countries like Germany, France and Japan.
- This Paper helps us to control train without a driver and the stations are shown on the LCD so passenger does not have any difficulty.
- Transportation System.



## CONCLUSION

The main reason behind this paper is to raise the attractiveness of public transport and ultimately contributing to improving the quality of life in our cities. This paper implemented for the new technology development to the metro train. This paper will greatly reduce the human intervention in the control of trains and hence saves time and money.

## REFERENCES

- [1] Prakash Ratan And Chandra jogi-“Auto metro Train To shuttle Between Stations”, International Journal and Magazine of Engineering, Technology, Management and Research.
- [2] Er.Thakurendra Singh And Nidhi Singh- “Auto Metro Train Shuttle Between Two Stations”, International Journal of Electrical and Electronics Research.
- [3] Thabit Sulan Mohammed And Wisam Fahmi Al-Azoo-“Full Automation in Driverless Train”, International Journal of advanced research in Electrical, Electronics and Instrumentation Engineering.
- [4] V.Shridhar-“automated System Design for Metro Train”, International Journal of Computer Science Engineering.
- [5] Mohan, Dinesh, “Mythologies, Metro Rail System and Future Urban Transport,” in Proc. Economic & Political Weekly, Jan. 2007, pp. 41-53.
- [6] PIC Microcontroller and Embedded Systems: Using Assembly and C for PIC18 by Muhammad Ali Mazidi, Rolin D. McKinlay, Danny Causey.