



# Peak-to-Average Power Ratio Reduction in OFDM system using Block Coding technique

Ashish K. Thakre<sup>1</sup>, Snehal B. Meshram<sup>2</sup>

Lecturer, Dept of Electronics, SDMP., Nagpur, Maharashtra, India<sup>1</sup>

M-Tech 4<sup>th</sup> Sem, Communication Engg., YCCE Nagpur, Maharashtra, India<sup>2</sup>

**Abstract-** One of the challenging issues for Orthogonal Frequency Division Multiplexing (OFDM) system is its high Peak-to-Average Power Ratio (PAPR). In this paper, we review and analysis different OFDM PAPR reduction techniques, based on computational complexity, bandwidth expansion, spectral spillage and performance. The proposed scheme is termed sub-block complement coding (SBCC). Performance results obtained with SBCC are given and compared with that of the standard complement block coding (CBC), cyclic coding (CC), simple block coding (SBC), modified simple block coding (MSBC) and simple odd parity code (SOPC) for the same purpose. The results show that, at the same coding rate 3/4, the proposed scheme can achieve almost the same performance as the cyclic code but with lower complexity. But under the same coding rate, the PAPR reduction obtained by using SBCC is better than the rest schemes. The flexibility on choosing the coding rate and low complexity makes that the proposed scheme SBCC is more suitable for the large frame size with high coding rate and can provide error detection..We also discuss some methods of PAPRReduction.

**Keywords -** Sub-block complement coding(SBCC), (OFDM)Orthogonal frequency division multiplexing, high power amplifier (HPA), peak-to-average power ratio (PAPR)

## I. INTRODUCTION

Wireless digital communication is rapidly expanding resulting in a demand for wireless systems that have high data rate communication and has been deployed in many standards. OFDM is one of the MCM which offers high spectral efficiency, multipath delay spread tolerance, immunity to frequency selective fading channels and power efficiency.

With the rapid growth of digital communication in recent years, the need for high-speed data transmission has increased. The mobile telecommunications industry faces the problem of providing the technology that be able to support a variety of services ranging from voice communication with a bit rate of a few kbps to wireless Multimedia in which bit rate up to 2 Mbps. Many systems have been proposed and OFDM system based has gained much attention for different reasons. Although OFDM was first developed in the 1960s, only recently has it been recognized as an outstanding method for high-speed cellular data communication where its implementation relies on very high-speed digital signal processing, and this has only recently become available with reasonable prices of hardware implementation.

### BLOCK CODING:

A simple block coding scheme was introduced by Jones et al. [3], and its basic idea is that mapping 3 bits data into 4 bits codeword by adding a Simple Odd Parity Code (SOBC) at the last bit across the channels. The main disadvantage of

SOBC method is that it can reduce PAPR for a 4-bit codeword. Later, Wulich applied the Cyclic Coding (CC) to reduce the PAPR [11]. In 1998, Fragia como proposed an efficient Simple Block Code (SBC) to reduce the PAPR of OFDM signals [12].

However, it is concluded that SBC is not effective when the frame size is large. Subsequently, Complement Block Coding (CBC) and Modified Complement Block Coding (MCBC) schemes were proposed to reduce the PAPR without the restriction of frame size [13], [14]. CBC and MCBC are more attractive due to their flexibility on choosing the coding rate, frame size and low implementation complexity. CBC and MCBC utilize the complementary bits that are added to the original information bits to reduce the probability of the peak signals occurrence.

In [15], [16], [18], authors used the Golay complementary sequences to achieve the PAPR reduction, in which more than 3-dB PAPR reduction had been obtained. Codes with error correcting capabilities has been proposed in [17] to achieve more lower PAPR for OFDM signals by determining the relationship of the cosets of Reed-Muller codes to Golay complementary sequences. While these block codes reduce PAPR, they also reduce the transmission rate, significantly for OFDM systems with large number of subcarriers.

Even if it is possible, the complexity is still too high. Based on this motivates, authors of [19] proposed a novel method of computation and reduction of the PAPR and it mainly introduced a specific phase shift to each coordinate of all possible code words where phase shifts are independent

of the code words and known both to transmitter, then it can be freely obtained more 4.5-dB PAPR reduction by using the optimized phase shifts. From this viewpoint, we also consider the coding scheme of PAPR reduction as a special phase optimization.

In summarization, the inherent error control capability and simplicity of implementation make coding method more promising for practical OFDM systems design.



However, the main disadvantage of this method is the good performance of the PAPR reduction at the cost of coding rate loss.

TABLE I  
 COMPARISON WITH DIFFERENT CODING SCHEMES

N	n	R	PAPR Reduction (dB)			
			CBC	SBC	MCBC	CC
4	1	3/4	3.56	3.56	-	3.56
8	1	7/8	2.59	2.52	-	3.66
	2	3/4	2.67	3.72	2.81	3.66
1	1	15/16	2.74	1.16	-	3.74
6	2	7/8	2.74	2.52	-	
	3	15/16	2.74	-	-	
	4	3/4	2.74	2.98	3.46	

II. DVBT MODEL

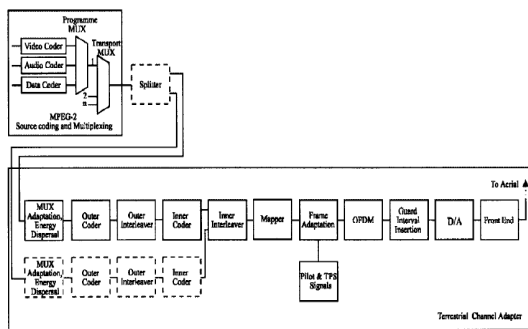

Figure 1.1: DVB-T transmitter [1]

A block diagram of the European DVB-T standard is shown in Figure 1.1. Most of the processes described in this diagram are performed within a digital signal processor (DSP), but the drawbacks occur in the physical channel; i.e., the output signal of this system. Therefore, it is the purpose of this project to provide a description of each of the steps involved in the generation of this signal and the Matlab code for their simulation. DVB-T as a digital transmission delivers data in a series of discrete blocks at the symbol rate. DVB-T is a COFDM transmission technique which includes the use of a Guard Interval. It allows the receiver to cope with strong multipath situations. Within a geographical area, DVB-T also allows single-frequency network (SFN) operation, where two or more transmitters carrying the same data operate on the same frequency. In such cases the signals from each transmitter in the SFN needs to be accurately time-aligned, which is done by sync information in the stream and timing at each transmitter referenced to GPS.

The length of the Guard Interval can be chosen. It is a trade off between data rate and SFN capability. The longer the guard

interval the larger is the potential SFN area without creating intersymbol interference (ISI). It is possible to operate SFNs which do not fulfill the guard interval condition if the self-interference is properly planned and monitored.

III. MATHEMATICAL ANALYSIS

1) CHARACTERISTICS OF OFDM SIGNALS:

Let a block of N symbols  $X = \{X_k, k = 0, 1, \dots, N-1\}$  is formed with each symbol modulating one of a set of subcarriers  $\{f_k, k = 0, 1, \dots, N-1\}$ , where N is the number of subcarriers. The N subcarriers are chosen to be orthogonal, that is  $f_k = k\Delta f$ , Where  $\Delta f = \frac{1}{NT}$

And T is the original symbol period. Therefore, the complex envelope of the transmitted OFDM signals can be written as

$$x(t) = \frac{1}{\sqrt{N}} \sum_{k=0}^{N-1} X_k e^{j2\pi f_k t}, \quad 0 < t < NT$$

IV. DEFINITION OF PAPER

A) Baseband PAPR:

Continuous-time PAPR:

In general, the PAPR of OFDM signals  $s(t)$  is defined as the ratio between the maximum instantaneous power and its average power

$$PAPR[x(t)] = \frac{0 \leq t \leq NT [x(t)]^2}{P_{av}}$$

B) Passband PAPR:

OFDM system usually does not employ pulse shaping, since the power spectral density of the band-limited OFDM signal is approximately rectangular. Thus, the amplitude of OFDM RF signals can be expressed as

$$x_{PB}(t) = \{\Re\{x(t)e^{j2\pi f_c t}\}\}$$

C) Block coding :

Consider as an example that BPSK modulation is used in conjunction with an N carrier system. The power of each individual carrier is normalised to 1 W while the envelope power is equal to  $p(t) = s(t)s^*(t)$

where

$$s(t) = \sum_{n=1}^N d_n(t) e^{j(2\pi f_n t + \phi_n)}$$

In the above formula,  $\phi_n$  is the initial phase and for simplicity is assumed to be equal to zero,  $d_n(t)$  is the data stream applied to the Nth carrier represented by  $f_n$ , and A is the frequency of the Nth carrier.

V. PROPOSED MODEL

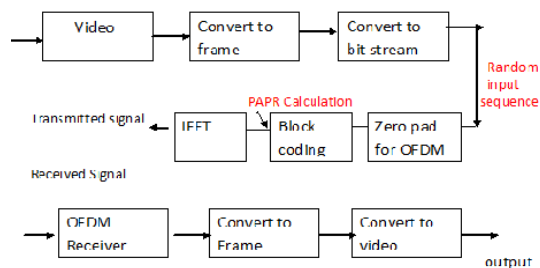

BLOCK DIAGRAM

In this model, we will transmit video which consist of frames. This frame is converted into bit stream which is passed through OFDM transmitter. We will calculate PAPR without applying any method. Then after applying Block Coding Technique we will calculate the PAPR. Further the signal is received by the OFDM receiver.

## VI. CONCLUSION

OFDM is a very attractive technique for wireless communications due to its spectrum efficiency and channel robustness. One of the serious drawbacks of in OFDM systems is PAPR. In this paper, we described several important aspects and Block Coding Technique. Specifically, a simple added bit code has been applied across the channels of a multicarrier system in order to reduce the peak power present. This has been achieved with a minimal increase in complexity and regardless of the number of channels present.

## REFERENCES

[1] T. Jiang, M. Guizani, H. Chen, W. Xiang, and Y. Wu, "Derivation of PAPR distribution for OFDM wireless systems based on extreme value theory," *IEEE Trans. Wireless Communications*, 2008.

[2] G. L. Ren, H. Zhang, and Y. L. Chang, "A complementary clipping transform technique for the reduction of peak-to-average power ratio of OFDM system," *IEEE Trans. Consumer Electronics*, vol. 49, no. 4, pp. 922–926, Nov. 2003.

[3] A. E. Jones, T. A. Wilkinson, and S. K. Barton, "Block coding scheme for reduction of peak-to-average envelope power ratio of multicarrier transmission systems," *IEE Electronics Letters*, vol. 30, no. 8, pp. 2098–2099, Dec. 1994.

[4] S. B. Slimane, "Reducing the peak-to-average power ratio of OFDM signals through precoding," *IEEE Trans. Vehicular Technology*, vol. 56, no. 2, pp. 686–695, Mar. 2007.

[5] H. Nikookar and K. S. Lidsheim, "Random phase updating algorithm for OFDM transmission with low PAPR," *IEEE Trans. Broadcasting*, vol. 48, no. 2, pp. 123–128, Jun. 2002.

[6] T. G. Pratt, N. Jones, L. Smee, and M. Torrey, "OFDM link performance with companding for PAPR reduction in the presence of nonlinear amplification," *IEEE Trans. Broadcasting*, vol. 52, no. 2, pp. 261–267, Jun. 2006.

[7] S. S. Yoo, S. Yoon, S. Y. Kim, and I. Song, "A novel PAPR reduction scheme for OFDM systems: Selective mapping of partial tones (SMOPT)," *IEEE Trans. Consumer Electronics*, vol. 52, no. 1, pp. 40–43, Feb. 2006.

[8] Y. J. Kou, W. S. Lu, and A. Antoniou, "A new peak-to-average power-ratio reduction algorithm for OFDM systems via constellation extension," *IEEE Trans. Wireless Communications*, vol. 6, no. 5, pp. 1823–1832, May 2007.

[9] R. J. Baxley and G. T. Zhou, "Comparing selected mapping and partial transmit sequence for PAR reduction," *IEEE Trans. Broadcasting*, vol. 53, no. 4, pp. 797–803, Dec. 2007.

[10] S. H. Han and J. H. Lee, "An overview of peak-to-average power ratio reduction techniques for multicarrier transmission," *IEEE Personal Communications*, vol. 12, no. 2, pp. 56–65, Apr. 2005.

[11] D. Wulich, "Reduction of peak to mean ratio of multicarrier modulation using cyclic coding," *IEE Electronics Letters*, vol. 32, no. 29, pp. 432–433, Feb. 1996.

[12] S. Fragicomo, C. Matrakidis, and J. J. O'Reilly, "Multicarrier transmission peak-to-average power reduction using simple block code," *IEEE Electronics Letters*, vol. 34, no. 14, pp. 953–954, May 1998.

[13] T. Jiang and G. X. Zhu, "Complement block coding for reduction in peak-to-average power ratio of OFDM signals," *IEEE Communications Magazine*, vol. 43, no. 9, pp. S17–S22, Sept. 2005.

[14] T. Jiang and G. X. Zhu, "OFDM peak-to-average power ratio reduction by complement block coding scheme and its modified version," in *The 60th IEEE Vehicular Technology Conference 2004 Fall*, Los Angeles, USA, Sept. 2004, pp. 448–451.

[15] S. Boyd, "Multi tone signals with low crest factor," *IEEE Trans. Circuits Systems*, vol. CAS-33, no. 10, pp. 1018–1022, Oct. 1986.

[16] B. M. Popovic, "Synthesis of power efficient multi tone signals with flat amplitude spectrum," *IEEE Trans. Communications*, vol. 39, no. 7, pp. 1031–1033, Jul. 1991.

[17] T. Jiang, G. X. Zhu, and J. B. Zheng, "A block coding scheme for reducing PAPR in OFDM systems with large number of subcarriers," *Journal of Electronics*, vol. 21, no. 6, pp. 482–489, Dec. 2004.

[18] J. A. Davis and J. Jedwab, "Peak-to-mean power control in OFDM, Golay complementary sequences and Reed-Muller codes," *IEEE Trans. Information Theory*, vol. 45, no. 7, pp. 2397–2417, Nov. 1997.

[19] V. Tarokh and H. Jafarkhani, "On the computation and reduction of the peak-to-average power ratio in multicarrier communications," *IEEE Trans. Communications*, vol. 48, no. 1, pp. 37–44, Jan. 2000.