



# A Review Paper: Security on Voice over Internet Protocol from Spoofing attacks

Sanjay Kumar Sonkar<sup>1</sup>, Rahul Singh<sup>2</sup>, Ritu Chauhan<sup>3</sup>, Ajay Pal Singh<sup>4</sup>

Dept. of Computer Science and Engineering, Kamla Nehru Institute of Technology, UttarPradesh, India.

Dept. of Computer Science and Engineering, Sharda University, UttarPradesh, India.

Dept. of Electronics and Communication Engineering, Sharda University, UttarPradesh, India.

Dept. of Computer Science and Engineering, Kamla Nehru Institute of Technology, UttarPradesh, India.

<sup>1</sup>kumarsanjaysonkar@gmail.com, <sup>2</sup>rahulsingh.tech@gmail.com, <sup>3</sup>ritu.chauhan.94@gmail.com, <sup>4</sup>apsingh3289@gmail.com

**ABSTRACT-** *Voice over Internet protocol (VoIP), there is an existing way of communication over any network. The Users can make the telephone calls over an IP network using this technology. This paper will describe Voice over Internet Protocol (VoIP) to a level that allows discussion of security issues and concerns. There are two kinds of spoofing attacks are possible, first one is IP spoofing attack and another is URI spoofing attack, which are described in this review paper. The Implementation of VoIP concerned by businesses, components of a VoIP system, and relevant security issues. The business concerns will be those which are used to affect the Quality of Service (QoS). The network components call processors, gateways and two of the more common architectures are held by VoIP.*

**Keywords-** VoIP, H.323, SIP, MGCP, QoS, Spoofing Attacks.

## I. INTRODUCTION

To transmit voice conversations over a data network using IP, VoIP technology is used. Such data network may be the Internet or a corporate Intranet or managed networks which are specially used by long distance and local service traditional providers and ISPs (Internet Service Provider).

Voice over Internet Protocol (VoIP) is a form of communication that allows end-user to make phone calls over a broadband internet connection. Basic VoIP access usually allows you to call others who are also receiving calls over the internet. Interconnected VoIP services also allow you to make and receive calls to and from traditional landline numbers, usually for a service fee. A special type of adapter is used in some VoIP services which required a computer and a dedicated VoIP telephone. Other services allow to end-users to use own landline phone, it is used to replace VoIP calls. All these paradigms are held by a special adapter.

Voice over IP refers to the diffusion of voice traffic over internet-based networks. Internet Protocol (IP) was originally designed for data networking for purpose of its success, VoIP protocol has been adapted to voice networking.

The history of VoIP began with conversations by a few computer users over the Internet. Initially, VoIP required a headset to be plugged into the computer, and the participants could only speak with others who had a similar set up. They

had to phone each other ahead or sent a text message, in order to alert the user at the other end of the incoming call and the exact time [2].

In November 1977, the IETF published the ‘Specifications for the NVP (network voice protocol)’. In the preface to this document, the objectives for the research were explained as the development and the demonstration of the ‘feasibility of secure, high-quality, low-bandwidth, real-time, full-duplex1 digital voice communications over packet-switched computer communications networks [3].

In the mid-90s, IP networks were growing, the technology had progressed and the use of personal computers had grown extensively. The belief that VoIP could start to make some impact on the market resulted in high expectations and the distribution of the first software package.

In its early stages, the VoIP technology was not sufficiently mature. There was a big gap between the marketing structure and the technological reality. It results in an overall agreement that technical shortages stopped any major transition to VoIP. However, VoIP is continued to make technical and commercial progress. The most of the technical problems have been solved by VoIP technology. There are no restrictions in the limited market conditions [4].

The communications network providers are used to adopt IP in their infrastructure, enterprises are adopting IP for private corporate networks. The communication between

employees facilitate by using VoIP technique, whether working at corporate locations, working at home, or travelling. VoIP can also augment corporate efficiencies.

There are several enterprises which are used to test VoIP, doing a tryout, or engaging in incremental upgrades. The majority of multinational corporations use VoIP instead of remote possibility. The business opportunity will be a major part of their business operations in the near future [5].

This paper is divided into seven parts. Starting with introduction (Section-I), next section covers the implementation of VoIP (Section-II). Moving ahead, Configuration of VoIP is discussed (Section-III). After that VoIP attacks are discussed (Section-IV), How to Protect against Risks are discussed (Section-V). More over Requirements, Availability and Service Limitations are discussed (Section-VI) and finally, conclusions summarizes the last section (Section-VII).

## II. IMPLEMENTATION OF VoIP

In this section first we will discuss VoIP protocols and after that data processing in VoIP, at last we will discuss about quality of service in VoIP systems.

### a. Protocols

There are currently three types of protocols which are widely used in VoIP implementations: the H.323 family of protocols, the Session Initiation Protocol and the media Gateway Controller Protocol (MGCP). The discussion of these protocols is as follows:

- *H.323 Family of Protocols*

H.323 [8], [9] is a set of recommendations from the International Telecommunication Union (ITU) and consists of family of protocols that are used for call set-up, call termination, registration, authentication and other functions. These protocols are transported over TCP or UDP protocols. The following figure.1 shows the various H.323 protocols with their transport mechanisms. H.323 family of protocol consists of H.225 which is used for registration, admission, and call signaling. H.245 is used to establish and control the media sessions. T.120 is used for conferencing applications in which a shared white-board application is used. The audio codec is defined by G.7xx series by H.323, while video codec is defined by H.26x series of specifications. H.323 uses RTP for media transport and RTCP is used for purpose of controlling RTP sessions. The following figure.2 & figure.3 shows the H.323 architecture and call set-up process.

- *Session Initiation Protocol (SIP)*

The modification and termination sessions between two or more participants the IETF is used which is defined by SIP

(session initiation protocol) [9]. These sessions are not limited to VoIP calls. The SIP protocol which is a text-based protocol, it is similar to HTTP and offers an alternative to the complex H.323 protocols. SIP protocol become more popular in comparison to H.323 family of protocol because it is more similar than it. The following figure.4 and figure.5 shows the SIP architecture, call set-up and tear down process.

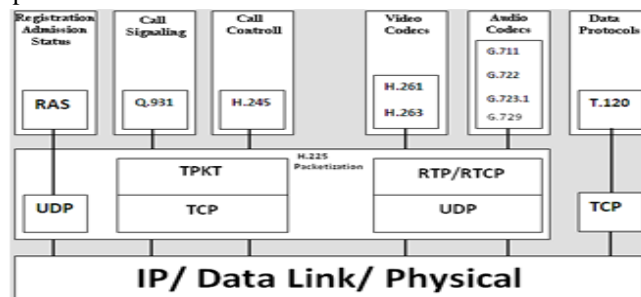

Fig.1 H.323 Protocol family [19]

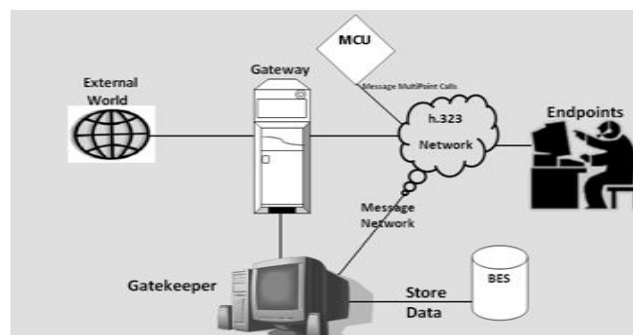

Fig. 2 H.323 Architecture [20]

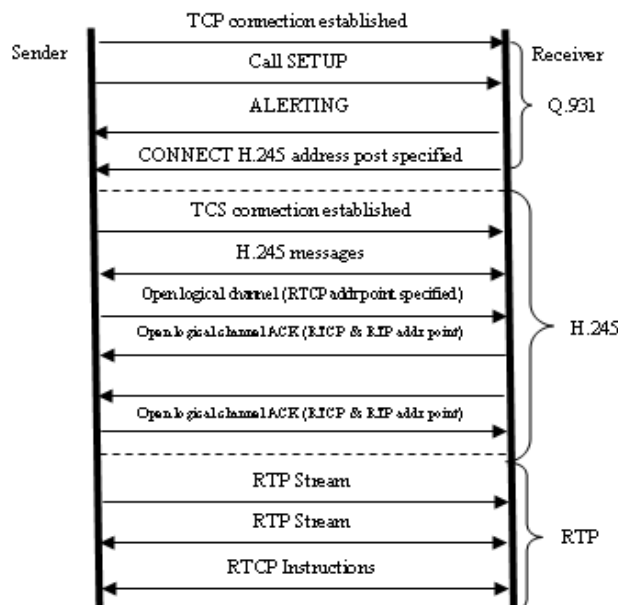

Fig. 3 Call Setup Process in H.323 [20]

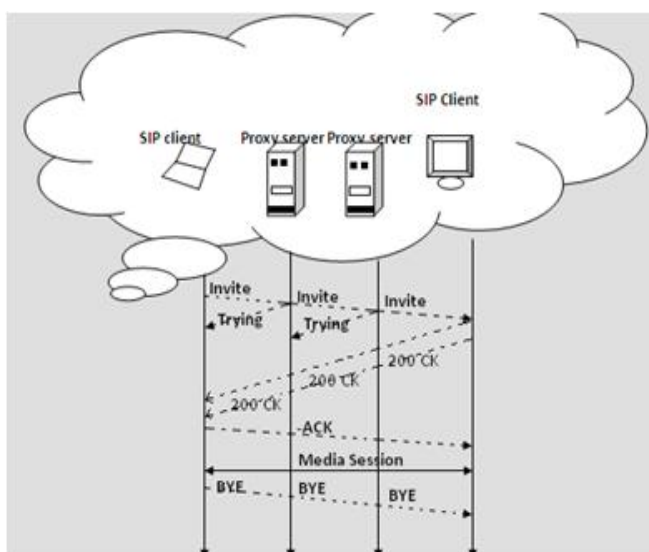

Fig. 4 SIP Network Architecture [9]

their control. MGCP does not define a mechanism for synchronizing call agents. MGCP is a master/slave protocol with a closely coupling between the MG (endpoint) and MGC (server).

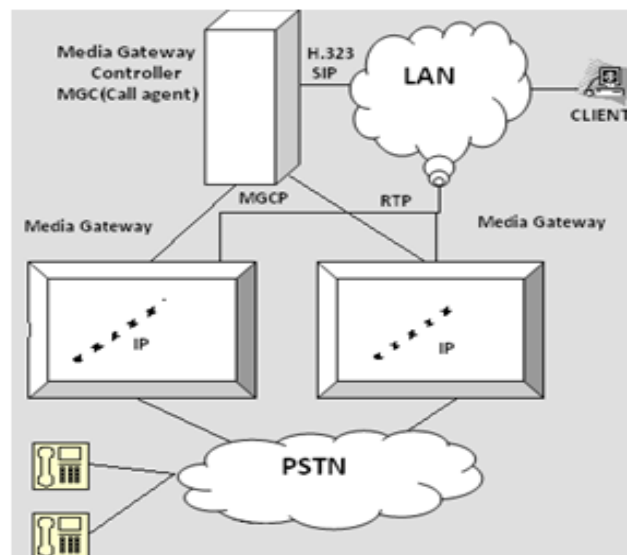

Fig. 6 MGCP Architecture [19]

#### b. Data Processing in VoIP Systems

There are three types of essential components in VoIP: CODEC (Coder/Decoder), packetizer and playout buffer [10], [11]. The analog voice signals are converted into digital signals at sender's side, after that these digital signals are compressed and then encoded into a predetermined format using voice codec. There are various voice codecs developed and standardized by International Telecommunication Union-Telecommunication (ITU-T) such as G.711, G.729, and G.723 etc. The packetization process is performed by distributing fragmented encoded voice into equal size of packets.

Furthermore, in each packet, some protocol headers from different layers are attached to the encoded voice. Protocol headers added to voice packets are of Real-time Transport protocol (RTP), User Datagram Protocol (UDP), and Internet Protocol (IP) as well as Data Link Layer header. In addition, RTP and Real-Time Control Protocol (RTCP) were designed to support real-time applications at the application layer.

Although TCP transport protocol is commonly used in the internet, UDP protocol is preferred in VoIP and other delay-sensitive real-time applications. TCP protocol is

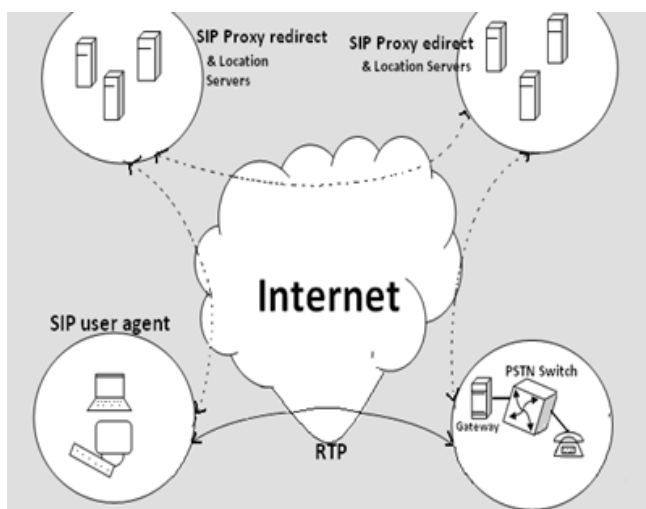

Fig. 5 Call setup and tear down in SIP [9]

#### • Media Gateway Control Protocols (MGCP)

The communication between the separate components of a decomposed VoIP gateway is done by media gateway control protocol. It is a complementary protocol to SIP and H.323. "Call agent" is mandatory and manages calls and conferences, when we are using MGCP and MGC server (Figure 6). The MG endpoint is not responsible for calls and conferences. It does not maintain call states. MGs are responsible to execute commands sent by the MGC call agents. MGCP assumes that call agents will synchronize with each other sending coherent commands to MGs under

suitable for less delay-sensitive data packets and not for delay-sensitive packet due to the acknowledgement (ACK) scheme that TCP applies. This scheme introduces delay as receiver has to notify the sender for each received packet by sending an acknowledgement. The UDP protocol cannot be applied to VoIP technology. It is more suitable for VoIP applications.

The packets are then sent out over IP network to its destination where the reverse process of decoding and de-packetizing of the received packets is carried out. The time variations of packet delivery (jitter) may occur in transmission process. Hence, a play out buffer is used at the receiver end to migrate the package without any interruption. Packets are queued at the playout buffer for a playout time before being played. However, these packets continued to arrive until the playout time is discarded. The fig.7 shows the end –to- end transmission of voice in VoIP system.

Besides, there are signaling protocols of VoIP namely Session Initiation Protocol (SIP) and H.323. These signaling protocols are required at the very beginning to establish VoIP calls and at the end to close the media streams between the clients.

Fig. 7 End-to End Voice Transmission [3]

c. *Quality of Service (QoS) in VoIP Systems*

Quality of service (QoS) [3] can be defined as the network ability to provide good services that satisfy its customers. In other words, QoS is used for measurement of the degree of user satisfactions. When degree of user satisfactions is higher than it means the QoS is also higher. QoS are briefly described as given below:

- *Delay*

Delay can be defined as the total time it takes since a person, communicating another person, speaks words and hearing them at the other end. Delay can be categorized into three categories: delay at the source, delay at the receiver and network delay [3].

- *Jitter*

IP network does not guarantee of packets delivery time which introduces variation in transmission delay. This variation is known as jitter and it has more negative effects on voice quality [3], [4].

- *Packet Loss*

Packets transmitted over IP network may be lost in the network or arrived corrupted or late. Packets would be discarded, when they arrive late at the jitter buffer of the receiver or when there is overflow in jitter buffer or router buffer. Therefore, packet loss is equal to the total loss occurs during congestion of network and late arrival [5]. During the packet loss, the sender is informed to retransmit the lost packets. It causes more packet delay and it affects transmission QoS.

- *Echo*

In VoIP, Echo occurs when a caller at the sender side hears the reflection of his own voice after he talked on the phone or the microphone, whereas the callee does not notice the echo. Echo is the term of the reflections of the sent voice signals by the far end. Echo could be electrical echo which exists in PSTN networks or echo of sound which is an issue in VoIP networks [6].

- *Throughput*

The throughput may be defined as the maximum number of bits received out of the total number of bits sent during an interval of time.

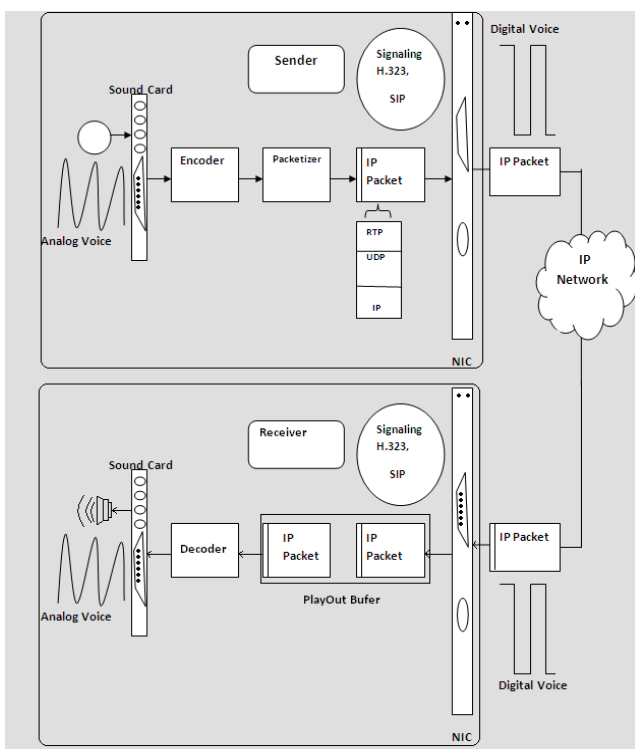



### III. CONFIGURATIONS OF VoIP

#### *Dedicated routers*

These devices allow any user to use its own traditional phone to place VoIP calls. They are connected to cable/DSL modems (or any high-speed internet source) and allow any user to attach an ordinary telephone. Once these routers are configured with an appropriate VoIP provider and service plan, there is no need of special software or interaction with a computer. In fact, there is only need to pick up your phone and dial a number at the dial tone. You can also bring your own adapter with you when you travel and make calls wherever broadband internet access is available.

#### *Adapters (USB)*

USB devices also allow you to use a traditional phone to place VoIP calls. They usually come in the form of USB adapters that are slightly larger than the typical thumb drive. They feature a standard modular phone jack to which you can attach an ordinary phone line. Once connected, your phone behaves as if it were connected to standard phone service.

#### *Software-controlled VoIP applications: “softphones”*

There are many software applications (“softphones”) that allow you to place VoIP phone calls directly from an ordinary computer with a headset, microphone, and sound card. Internet telephony service providers usually give away their softphones but require that you use their service. Together, these applications and services enable users to talk to other people using the same service at no cost, and to the rest of the world for a fee. Software-based VoIP applications are quite attractive to consumers because they often already have most of the components necessary to get started at little to no cost.

#### *Dedicated VoIP phones*

A VoIP phone looks like an ordinary corded or cordless telephone, but it connects directly to a computer network rather than a traditional phone line. A dedicated VoIP phone may consist of a phone and base station that connects to the internet or it may also operate on a local wireless network. Like the VoIP adapters mentioned above, dedicated VoIP phones also require a provider as well as a required service plan.

### IV. VoIP attacks

#### *Malformed Message Attack*

Malformed Message Attack is one of the most representative cases using the vulnerabilities of text-based protocol. These attackers are able to cause malfunctions of proxy server by manipulating SIP headers. For instance, overflow-space, overflow-null, specific header deletion and using non-ASCII code are involved in these malformed message attacks.

#### *SIP Flooding Attack*

IP phones generate requests or responses to send to a specific UA, called by victim. As a result, a single UA is overwhelmed by receiving excessive SIP messages within a short duration of time, so that the UA cannot provide normal services. INVITE flooding is one of the most typical attacks. Basically, flooding attack is also the issue of IP layer. In case of INVITE flooding, however, it could be more annoying attack for the VoIP user because the one should see many call requests at the same time and hear ringing of calls.

#### *Spoofing Attack*

Spoofing [18] can be done when an attacker searches to be someone else in order gain access to restricted resources or steal information. This type of attack can take a variety of different forms; for instance, an attacker can change in the protocols which are used as the Internet Protocol (IP). The address of authorized user is given in order to get into their accounts. Also, an attacker may send fraudulent emails and set up fake websites in order to capture user’s login names, passwords and account information. A phishing attack is any fake email or websites. Another type of spoofing involves setting up a fake wireless access point and tricking victims into connecting to them through the unauthorized connection.

There are two kinds of spoofing attacks are possible, first one is IP spoofing attack and another is URI spoofing attack. IP spoofing attack is to make a way for IP source addresses in order to feign a trusted user and IP spoofing having the intrinsic security problem in TCP/IP protocol suites and it is not in the scope of our study on VoIP security. The URI spoofing attack is a particular case in malformed message attacks. The attacker who hijacked SIP messages between two UAs forges their URI field, so the attacker can hide himself from tracebacks. If spoofed BYE requests (BYE DoS attack) are sent to a victim, then the call would be terminated by this attacker.

#### *Threats / Risks*

Many of the threats associated with VoIP are similar to the threats inherent to any internet application. Internet users

are already familiar with the difficulties of email abuse in the form of spam. VoIP opens yet another pathway for these annoyances, which can lead to spam over internet telephony (SPIT), spoofing and identity theft.

#### *Spam over internet telephony (SPIT)*

VoIP spam is unwanted, automatically dialed, pre-recorded phone calls using Voice over Internet Protocol (VoIP). It is similar to E-mail spam.

#### *Spoofing*

It is technically possible for an attacker to masquerade as another VoIP caller. For example, an attacker could possibly inject a bogus caller ID into an ordinary VoIP call so that the receiver believes the call to be coming from a known and trusted source. The receiver, fooled by the electronic identification of the caller, may place unwarranted trust in the person at the other end. In such an exchange, the receiver may be tricked into disclosing personal information like account numbers, social security numbers, or secondary authentication factor: a mother's maiden name, for example. This scheme is essentially the VoIP version of traditional phishing, where a user follows links in an unsolicited email and is tricked into providing personal information on a bogus web site. Attackers may use these bits and pieces of personal information to complete partial identity records of victims of identity theft.

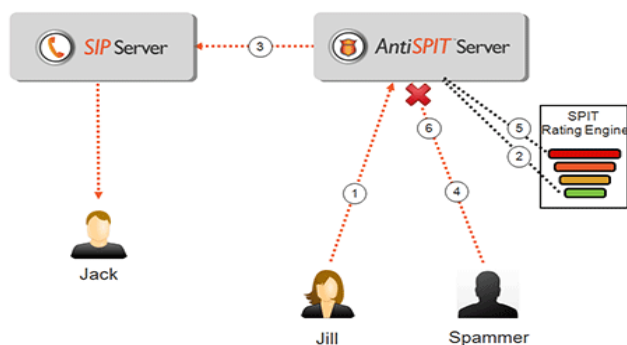

Fig. 8 SIP & SPIT server [16]

#### *Confidentiality concerns*

The concern is that VoIP data sometimes travels unencrypted over the internet. Therefore, it is technically possible for someone to collect VoIP data and attempt to reconstruct a conversation. Although it is extremely difficult to achieve, some software programs are designed to piece together bits and pieces of VoIP data in an effort to

reconstruct conversations. While such activity is currently rare, you should be aware of this possibility as it may increase as VoIP becomes more widespread.

#### **V. How to Protect Against Risks**

The “Voice VLAN” is a special access port feature of Ethernet Switches which allows IP Phones to configure automatically and easily associate to a logically separate VLAN. This feature provided various benefits, but one particular benefit is when the Voice VLAN is enabled on a switch port that is also enabled to allow simultaneous access for a regular PC. This feature allows a PC to be daisy chained to an IP Phone and the connection for both PC and Phone to be trunked through the same physical Ethernet cable.

Enabling Voice VLANs raises the complexity to properly secure these physical Ethernet ports. Enabling without the proper security controls in place can increase the risk to an organization.

There are several types of the principles as well as the practices for safe VoIP usage are the same. However, you may already practice with other internet applications. There are some of the key practices of good personal computing:

- Use and maintain anti-virus and anti-spyware programs.
- Be cautious about opening files attached to email messages or instant messages.
- Verify the authenticity and security of downloaded files and new software.
- Configure your web browser(s) securely.
- Use a firewall.
- Identify, back-up, and secure your personal or financial data.
- Create and use strong passwords.
- Patch and update your application software.
- Do not disclose personal information to people to whom you don't know individually.

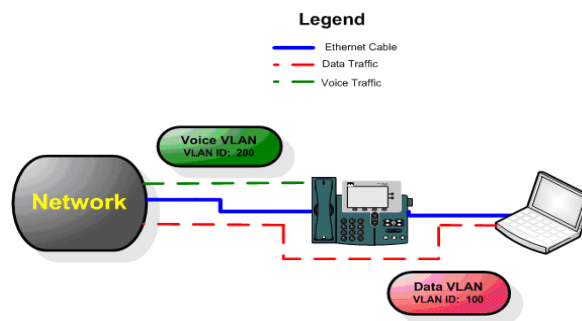



Fig. 9 A typical VoIP scenario in which data and voice traffic is transmitted through the same cable [17]

## VI. Requirements, Availability and Service Limitations

If you want to consider about the VoIP service, you should not assume its features, functionality and options. These will equal to those of traditional landlines. You should be familiar with these requirements, availability and possible service limitations of VoIP service before switching to VoIP as either a primary means of communication or an enhancement to your current services.

### *Requirements*

VoIP requires a connection to the Internet through an ISP, a VoIP service to extend the reach to traditional landlines, and VoIP software to actually place calls. Plain Old Telephone Service (POTS) requires none of these prerequisites. It is important to note that Digital Subscriber Line (DSL) internet service uses traditional phone lines for your internet connection. In this case, you already have telephone service to begin with. You may wish to weigh the expected benefits of VoIP against these costs. These costs are given to your current operating environment. There is no need of any prerequisites in POTS.

### *Availability due to power outages*

VoIP becomes unavailable, during a typical power outage because VoIP devices (computers, routers, adapters) usually rely on a power source to provide its functionality. Traditional phone lines are usually still available during such an outage, which is a major advantage in an emergency.

### *Availability due to bandwidth*

VoIP communication always requires a high-speed (broadband) internet connection to provide a reliable functionality. Even given typical broadband connection speeds, though, service interruptions or degradation of quality is possible due to high internet traffic. For example, if you are trying to place a VoIP call while other people are using a lot of bandwidth on the same internet connection, then the quality of sound of your own VoIP call or general VoIP availability may also be affected.

## VII. CONCLUSIONS

Security for a VoIP system should begin with solid security on the internal network. It should be protected from the threats of attached hostile networks and the threats of the internal network. The security policy should include any specific VoIP needs. The load of the VoIP system should be

accommodated by the network and the servers involved, ensuring that proper resources are in place and available. A dedicated VoIP phone may consist of a phone and base station that connects to the internet or it may also operate on a local wireless network. Conducting a risk analysis of each component and process will identify the vulnerabilities and threats. This will provide the information needed to determine proper measures. There should be a proper balance between the security and the business needs of the organization. It is the key to the success of any VoIP deployment.

## REFERENCES

- [1]. H. Yong-feng, Z. Jiang-ling, "Implementation of ITU-T G. 729 speech codec in IP telephony gateway" Wuhan University Journal of Natural Sciences, Volume 5, Number 2, June 2000.
- [2]. M. Habib, N. Bulusu, "Improving QoS of VoIP over WLAN (IQ-VW)", Project Research Paper, for CS522 Computer Communications, University of Colorado at Colorado Springs, December 2002.
- [3]. P. M. Athina., A. T. Fouad and J. K. Mansour, "Assessing the Quality of Voice Communications Over Internet Backbones", IEEE/ACM Transactions on Networking, Vol. 11, No. 5, Oct. 2003.
- [4]. Qiu, P.Q., Monkewich, O., and Probert, R.L., "SIP Vulnerabilities Testing in Session Establishment and User Registration" ICETE (2), 223-229., 2004.
- [5]. J. B. Meisel, M. Needles, Voice over Internet protocol (VoIP) development and public policy implications, Info 7, 2005.
- [6]. Advisory Committee on International Communications and Information Policy (ACICIP), 2005.
- [7]. D. Richard Kuhn, Thomas J. Walsh, Steffen Fries, Security Considerations for Voice over IP Systems, Recommendations of the National Institute of Standards and Technology, NIST Special Publication 800-58, 2005.
- [8]. <http://www.isoc.org/pubpolpillar/voip-paper.shtml> 15.08.2006.  
<http://www.eyeball.com/spit-solution.htm>.
- [9]. K. M. McNeill, M. Liu and J. J. Rodriguez, "An Adaptive Jitter Buffer PlayOut Scheme to Improve VoIP Quality in Wireless Networks", IEEE Conf. on BAE Systems Network Enabled Solutions, Washington, 2006.
- [10]. C. Lin, X. Yang, S. Xuemin and W.M. Jon, "VoIP over WLAN: Voice capacity, admission control, QoS, and MAC", International Journal of communication Systems, Vol.19, No 4, pp. 491-508, May 2006.
- [11]. L. Mintandjian, P.A. Naylor, "A Study Of Echo In Voip Systems And Synchronous Convergence Of The  $\mu$ -Law Plms Algorithm", 14<sup>th</sup> European Signal Processing Conference (EUSIPCO 2006), Florence, Italy, September 4-8, 2006.
- [12]. Seedorf, J., "SIP Security: Status Quo and Future Issues", Talk presented at 23rd Chaos Communication Congress, 2006.
- [13]. Russel, T., "Session Initiation Protocol (sip) Controlling Convergent Networks" McGrawHill Professional, 2008.

[http://www.symantec.com/connect/articles/voip-hopping-method-testing-voip-security-or-voice-vlans.](http://www.symantec.com/connect/articles/voip-hopping-method-testing-voip-security-or-voice-vlans)  
<http://www.computer-network-security-training.com/what-is-a-spoofing-attack/>

- [14]. A Survey on Voice over IP over Wireless LANs Haniyeh Kazemitabar, Sameha Ahmed, Kashif Nisar, Abas B Said, Halabi B Hasbullah World Academy of Science, Engineering and Technology 2010.
- [15]. A comparison of sip and h.323 for internet telephony henning schulzrinne department of computer science, Columbia university new York.
- [16]. A comprehensive survey on a promising technology Stylianos Karapantazis, Fotini-Niovi Pavlidou Department of Electrical and Computer Engineering, Aristotle University of Thessaloniki, Panepistimioupoli, 54124 Thessaloniki, Greece.
- [17]. Comparative Analysis of Traditional Telephone and Voice-over-Internet Protocol (VoIP) Systems Hui Min Chong and H. Scott Matthews\* Department of Civil and Environmental Engineering Carnegie Mellon University Pittsburgh, PA USA.
- [18]. Rohit Dhamankar Intrusion Prevention: The Future of VoIP Security White paper.



Ajay Pal Singh was born at Mainpuri, U.P., (India). He received B.E. Degree in Information technology, from I. E. T. Khandari, Dr. B. R. Ambedkar University Campus, Agra in 2006. Presently he is pursuing M. Tech.

from Kamla Nehru Institute of Technology, Sultanpur, (U.P.), India. Before taking admission in M. Tech he was a permanent faculty in Siddhant College of engineering (Affiliated to University of PUNE). His fields of interests are software Engineering, Theory of Computation, Cryptography & Network Security Text data mining etc. Teaching and Research is his favorite field.

#### **Bibliography:**



Sanjay Kumar Sonkar was born at Varanasi, (U.P), in India. He received his B. Tech degree in Computer Science & Engineering in 2010 from Radha Govind Engineering College, Meerut, India. Presently, he is an M. Tech Student in Computer Science & Engineering from Kamla Nehru Institute of Technology, (KNIT), Sultanpur, U.P., India.



Rahul Singh was born at Shahjahanpur (U.P), in India. He received his B.Tech degree in Computer Science & Engineering in 2010 from Radha Govind Engineering College, Meerut, India. Presently, he is an M. Tech Student in Computer Science & Engineering from Sharda University, Greater Noida, U.P., India.



Ritu Chauhan was born at Panchkula (Haryana), in India. She received her B. Tech degree in Electronics & Communication Engineering in 2009 from Kurukshetra University, Kurukshetra, India. Presently, she is an M. Tech Student in VLSI Technology from Sharda University, Greater Noida, U.P., India.