

# At Mega 328 Microcontroller Based Firing Angle Control of 3phase Thyristor Bridge Rectifier Circuit

Mohan R. Gangul<sup>1</sup>, G.P. Jain<sup>2</sup>

PG Student, Department of Electronics, Walchand Institute of Technology, Solapur<sup>1</sup>

Associate Professor, Department of Electronics, Walchand Institute of Technology, Solapur<sup>2</sup>

**Abstract:** Controlled power is a fundamental prerequisite of various sectors. A scheme of microcontroller based firing angle control, using AT Mega 328 MCU & associated hardware circuitry is designed. Basic idea is to achieve reliable, consistent control that will result in improved performance of converter. Set-up consists of ATmega-328 controller, LCD display for displaying firing angle, transistorized conditioning circuit, main rectifier module and input from user in the form of analog voltage for firing angle control. Integration of these modules will result in full controlled converter with superior performance over other ordinary control techniques.

Design, development, testing, and installation of a firing controller for a tri phase thyristor rectifier. AT Mega 328 microcontroller is used as the firing controller. This IC chip provides logical input and output, analog-to-digital conversion, timer for the delay counting, and various interrupt vectors for timing. The software algorithm consists of the detection of the zero crossing of the synchronization voltage to start the timing of a period. A special test is programmed to control the value of the firing angle.

The design develops triggering circuit of 3-phase, 6-pulse, ac to dc controlled converter using AT Mega 328 microcontroller. The microcontroller will generate six equidistant, synchronized triggering pulses for the converter which finds application in power systems (high voltage DC transmission) and industrial drive systems. The controller is required to sense the input voltage and generate the required six trigger pulses irrespective of the variation of the mains frequency and to control the delay angle of these signals equally to control the DC output voltage.

**Keywords:** Microcontroller, AC/DC converter, Synchronization technique, gate triggering technique, DC motor.

## I. INTRODUCTION

Thyristorized circuits are normally preferred in applications where controlled power is a necessity. The three terminal thyristor has a terminal gate, along with anode and cathode, which shall be employed to trigger a thyristor at a particular angle, known as firing mechanism. It has been established that in analog triggering circuit, trigger circuit may consist of too many components, which may lead to debugging issues, as well, uneven spacing of the adjacent trigger pulses and shifting phase in accuracies may pose difficulties, there in. Hence digital trigger mechanism is designed, which overcomes the limitations of analog trigger circuit. In this schematic, digital trigger mechanism has been used for the control of output power.

A programmable pulse train is generated in desired sequence as output of microcontroller, using ATmega-328 controller. The pulse train manipulations is achieved through software program, which is then used for controlling converter's output. Through proper isolation these manipulated pulses are used for triggering SCR gates for power control operations.

Synchronization is achieved using sample from raw AC signal, by converting AC signal into square wave pulse through zero crossing detector and using it for the interrupt of MCU. Variable analog voltage (0-5 V)

is utilized through a pot-meter in an application, so that a user is able to control the firing angle. ADC port of ATmega-328 converts input variable analog voltage fed by a user into digital value.

By proper mathematical calculation the digital count can be used to trigger the converter circuit at desired firing angle, thereby controlling the output voltage.

## II. HARDWARE AND SOFTWARE MODULE

### A. Microcontroller and Peripheral board

An embedded microcontroller board based on Atmega microcontroller is designed. The microcontroller board contains sensor units, display circuits in the form of LCD screen, LEDs, etc. In addition to these components this board has various other components like, Real Time Clock (RTC) chip, serial port, four on-board keys for input, external interrupt pins, etc. This embedded board performs its operation using 9V battery or AC adapter.

### B. Software Module

The algorithms for implementation of this scheme are developed using embedded C language. The compilation of executable software code is achieved using ATmega, a development tools for the Atmega microcontroller, hosted on Windows. Similarly, Cygwin is software that provides a

Unix-like environment and software tool set for the users of any modern version of MS-Windows.

### III. METHODOLOGY

The block schematic of this digitally triggered converter circuit is depicted in Fig.1. The schematic arrangement consists of ATmega-328 controller, User controlled DC voltage input (0-5 V), LCD display for displaying firing angle, Zero Crossing Detector circuit and Converter Unit. Integration of all these blocks achieves full controlled converter with advanced performance over other regular control techniques Fig. 1 indicates the block diagram schematic, the brief description of these blocks is as given below

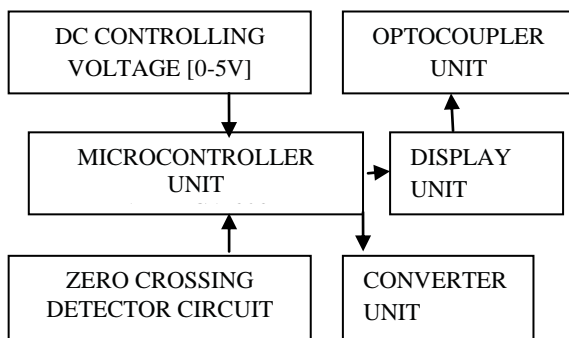

Fig. 1: Block diagram for controlling output power of converter

#### A 0-5 V Control Voltage

A user has a control over the output power by changing the control voltage. A potentiometer arrangement is provided to change an analog Voltage (0-5 V), used for controlling the converters output power. Port A is an ADC port of Atmega-328 microcontroller, which is of 10 bit resolution. Channel 0 and 1 are dedicated for light and temperature sensor, hence, channel 2 is used for accepting input analog voltage, fed by the user. Analog voltage is provided to a channel of ADC port. The input Analog Voltage (0-5 V) is converted in to (0-1023) counts. The change in the input analog voltage shall be proportionately converted to the change in digital count. This 10-bit internal ADC takes around 250 ms for conversion of analog value to digital value.

#### C Zero Crossing Detector Module

The ZCD module plays an important role for synchronization of the trigger pulses to power supply mains, for proper control of output power. The Zero Crossing Detector circuit distinguishes amongst the start of positive half cycle or negative half cycles. To have full control over the firing angle of the SCR, it is necessary to specifically detect the zero crossing of the sinusoidal input. Fig. 2 depicts a simple circuit which has been designed in this scheme for proper and accurate zero crossing detector. Here signal from mains is provided as a input, which is scaled down by transformer to the alternating voltage of inferior value around 12V. At collector terminal is obtained a square wave with amplitude of 4.88 volt.

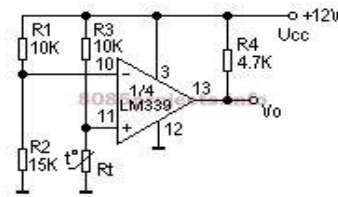

FIG: 2 Zero Crossing Detector Module

Flowchart given in Fig. 3 gives overall idea about the sequence in which the module works and about their connectivity.

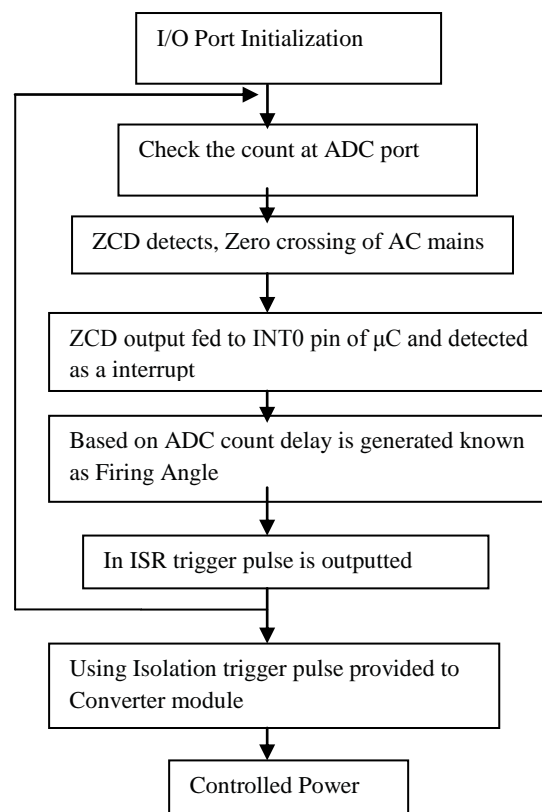

Fig. 3: Flowchart of digital triggering module

#### C Atmega-328 Microcontroller

Microcontroller unit accepts user input through a pot-meter in the form of an analog controlling voltage for channel 2 of ADC port, which is converted in to digital value. The digital value is used for generation of PWM. The output of the ZCD unit is a square wave signal. This square wave signal from zero crossing detectors is given at INT0 pin of ATmega-328. Falling edge of the square wave is detected as the interrupt. In interrupt subroutine first trigger pulse is produced using the PWM technique, which controls the magnitude of power delivered.

#### D. LCD Display

Microcontroller board with 2-line LCD display is used for showing the ADC value, as well as the corresponding firing angle. Values on the display are in real time, hence, with the change in the analog voltage, values of digital count and firing angle changes.

### E. Programming

Embedded C language is used for programming of Atmega microcontroller. Here Arduino IDE compiler is used. The compiled executable code in the form of .hex file can be downloaded in the microcontroller chip. This burning of the chip embeds the necessary instructions in the chip memory. BSD programmer is used for the said purpose. 280

### F. Production of Triggering Pulsation.

At any time when zero crossing (falling edge of square wave) is detected on the AC mains, microcontroller is interrupted and the latest values of ADC is used to influence firing delay which is use to determine firing angle with proper mathematical calculations. According to the firing angle, the triggering pulse is generated for gate terminal of SCR to trigger the thyristor. On LCD, ADC output and firing angle which is calculated from ADC reading is displayed for the observer (user), who is controlling the converters output.

ADC output ranges between 0-1023 count which is used to control firing angle 0-180. Let 'x' is the output from analog to digital converter and 'a' is a firing angle. So the relationship between firing angle and ADC count is given in equation (1).

$$a = x/5.68 \quad (1)$$

Here, it is desirable to estimate the delay as per the firing angle, where as the firing angle is based on the ADC count and ADC count is based on the input fed by the user, which is in the form of an analog voltage (0-5V). Hence, mathematical association between delay in the production of firing pulse and ADC count is established. The Converter output shall be controlled in the range 0-180. As the AC supply frequency is 50Hz, it has the time period of 20ms, i.e. for positive half cycle time period is 10ms. The ADC of ATmega328 is of 10-bit resolution, thereby, the maximum value from the ADC with +5 volts reference will be 1023, for which 10ms delay is required. The ADC reading is converted into a delay after which firing pulse is to be generated. Connection among ADC reading and firing angle delay is shown in equation (2). If 'x' is output of ADC and 'd' is delay in microseconds, then,

$$d = (x*5)*1.955 \quad (2)$$

Here, 1.955 is the scaling up factor for the ADC reading, and 5 is the reference voltage. Hence for ADC count = 1023, the delay 'd' will be 9999.825 microseconds, which is nothing but time period of half positive cycle, as mentioned above. MCU generates firing pulses on its output port with on-time of 100 microseconds. Fig. 4 shows the waveform of ZCD output and triggers pulse with firing angle of 900. Trigger pulse is outputted, when there is zero crossing of AC mains. When user input analog voltage is raised

up to 2.5 V, ADC output will be 512 and delay will be 5ms, triggering pulse is generated with the firing angle of 900.

### G. Separation between controlling and load circuit

The triggering pulse generated at the port A of ATmega 328 is 4.8V. This pulse is provided to the optocoupler MOC 3021, as the input signal.

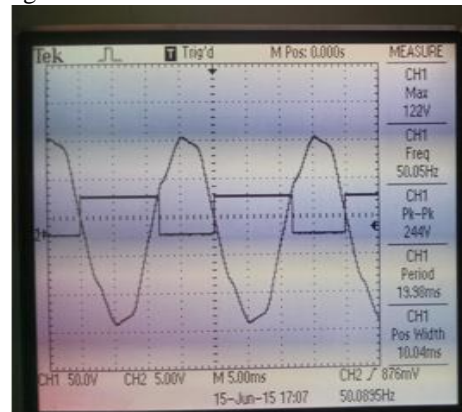

FIG 4 ZCD output

Fig. 5 indicates the optical isolation between controlling and load circuit. Here MOC 3021 module contains diode and DIAC. When triggering pulse is inputted to the optocoupler MOC 3021, through optical isolation gate pulse is provided to the thyristor BT151 as a result, the thyristor fired.

The programming flow is described as:

- i. ADC Module: Input Analog voltage (0-5 V) is fed to the ADC of ATmega-328 through port A, which is converted to 0 to 1023 count. This count after proper mathematical manipulation is used to generate the delay in the generation of trigger pulse.
- ii. ZCD Circuit: Zero Crossing Detector Circuit is used to detect the zero crossing of the AC signal; Synchronization is achieved with the help of raw AC signal as a input to ZCD. Square wave is output through the ZCD which is used to generate the interrupt. In ISR, the triggering pulse is outputted with the desired firing angle, corresponding to the input analog voltage (0-5 V).

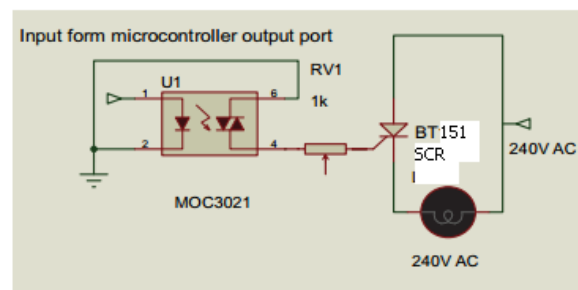

FIG 5 Optical isolation between control and load circuit.

- iii. Firing Pulse Production: When interrupt is detected the trigger pulse having Ton period of 100 micro second is use to trigger the thyristor, which provides output power. Thyristor gets commutated when the supply voltage becomes negative

because of natural commutation. In the next cycle again the interrupt is generated which is used to trigger the thyristor.

#### IV. RESULT

The Converter schematic is designed around the ATmega-328 microcontroller setup. Following are the numerical values obtained during experimentation, which fulfills the objective of providing controlled power, at accurate levels.

1. Input Analog voltage (0-5) is use as control voltage for incorporating variations in the firing angle. It is observed that for input voltage from 0V to 5V, ADC conversion time is constant which is 250msec. Analysis of Control Voltage, ADC count, Firing Angle, Delay is as mentioned in table I

2. ZCD is used to sense the zero crossing of AC mains, declining edge of square wave of ZCD output acts as an interrupt to microcontroller unit and trigger pulse is outputted. The different parameter with values for ZCD and trigger pulse from ATmega-328 controller port is as given in table II.

3. With the help of ATmega328 triggering pulse is generated. The pulse is provided to the thyristor through the optocoupler MOC3021 for the purpose of separation.

4. It is observed that there is synchronization in the generated trigger pulse with reference to ZCD and AC mains at the load side.

5. The circuit is tested for 3-phase converter, and it is observed that a trigger pulse of 100 micro second is sufficient to trigger the thyristor. The train of pulses is used as the triggering pulses for thyristor. In case the thyristor is not triggered on application of the first trigger pulse, then second pulse from the train of pulses will trigger the thyristor or even subsequent pulses shall trigger the thyristor. Fig. 6 indicates the trains of pulses are outputted after detection of falling edge of the square wave as interrupt.

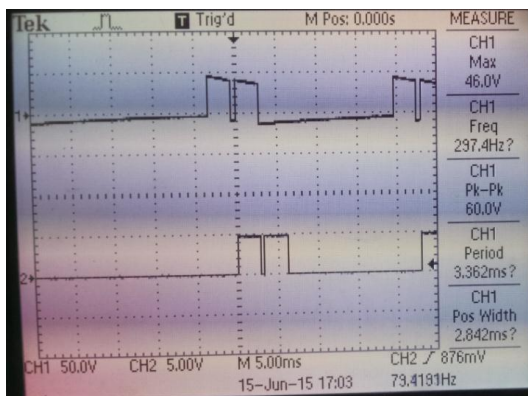

Fig.6: Train of pulses for triggering of SCR

6. This design has been fully tested and demonstrated. In an application, the incandescent lamps have been

put on as loads for thorough testing and verification of the results. It has been found that, the circuit is capable to fire the SCR at any angle ranging from 0 to 180 degrees without any noise or fluctuations on main lines. It is observed that when the control voltage is low, the firing angle is also low, more portion of positive half cycle is provided to the load (lamps), more voltage is made available at load, as indicated in Table-I. Moreover proportionate brightness of the lamps, corresponding to the input firing angle can be readily observed. When the control voltage increases, the firing angle goes on increasing, less portion of positive half cycle is provided to the load (lamp) less voltage is available at the load, as a result brightness of the lamp goes on decreasing.

7. For 3-phase full wave converter three Zero Crossing Detector Circuits are required to detect the individual phases for the 3-phase converter. After detection of three phases, interrupt is generated, at the falling edge of square waves as an output from the ZCDs. In interrupt sub routine six triggering pulses are generated, which are used for triggering the 6 thyristors as per the operation of the 3-phase full wave converter. Fig. 6 shows the waveforms of triggering pulses used for triggering of 3-phase converter. The triggering pulses for 4 thyristor are shown (because of unavailability of DSO ports). These triggering pulses are provided to the converter circuit using 6 optical isolation modules. By varying the input analog voltage the firing angle can be controlled, as a result of which output power of a 3-phase converter is controlled.

#### V. CONCLUSION

The design for a digital trigger circuit for Converter is widely tested and fulfills requirement of controlled output power, accurately. The circuit features an isolation from electromagnetic intervention at input and output side. Power control is available from 0-180 with user controlled input voltage. A Very few components are used in this design which are easily available and are cheap, to achieve cost economy and affordability. The design of the power control circuit is software based, hence can be easily upgraded to control other power devices for controlling power.

#### REFERENCES

- [1] B. Ilango, R. Krishnan, R. Subramanian, and S. Sadasivam, "Firing circuit for three-phase thyristor rectifier," IEEE Trans. Ind. Electron. Contr. Instrum., vol. IECI-25, no. 1, pp. 45-49, 1978.
- [2] L.H.Hoang, "A digitally controlled thyristor trigger circuit," Proc. IEEE, vol. 66, No.1, pp. 89-91, Jan. 1978.
- [3] S. Murugesan and C.Kameswara, "Simple adaptive analog and Digital trigger circuits for thyristors working under wide range of Supply frequency," IEEE Trans. Ind. Electron. Contr. Instrum., vol. IECI-24, No. 1, pp.46-49, 1977.
- [4] S.S.Upadhyaya, K. Kant and G. Singh, "A New Microprocessor Interfacing Hardware for SCR Triggering," proceeding of the IEEE, vol. 70, No. 10, October 1982.
- [5] Mr. Shashikant Lahade, S. R Hirekhan" Design and Implementation of Digital Trigger Circuit for Converter" IJERT Volume 1, Issue 3, May 2012.