

1-D Cursor Movement using Brain Computer Interface

Mr. Nilesh Zodape¹, Dr. Narendra Bawane², Pratik Hazare³

Student, Electronics Engg., S. B. Jain Institute of Technology, Management and Research, Nagpur, India¹

Principal, Electronics Engg., S. B. Jain Institute of Technology, Management and Research, Nagpur, India²

Assistance Professor, Electronics Engg., S. B. Jain Institute of Technology, Management and Research, Nagpur, India³

Abstract: The main idea of the current work is to use a wireless Electroencephalography (EEG) signal as a remote control for the mouse cursor of a personal computer. The proposed system uses EEG signals as a communication link between brains and computers. Signal records obtained from the PhysioNet EEG dataset were analyzed using the Coiflets wavelets and many features were extracted using PSD. The extracted features were inputted into machine learning algorithms to generate the decision rules required for our application. The suggested online system was tested and very good performance was achieved. This system could be helpful for disabled people as they can control computer applications via the imagination of 1D-cursor movement.

Keywords: EEG; BCI; Data Mining; Machine Learning; SVMs; NNs; DWT; Feature Extraction.

I. INTRODUCTION

Any natural form of communication or control requires peripheral nerves and muscles. The process begins with the user's intent. This intent triggers a complex process in which certain brain areas are activated, and hence signals are sent via Brain-Computer Interfaces: The peripheral nervous system (specifically, the motor pathways) to the corresponding muscles, which in turn perform the movement necessary for the communication or control task. The activity resulting from this process is often called motor output or efferent output. Efferent means conveying impulses from the central to the peripheral nervous system and further to effectors (muscle). Afferent, in contrast, describes communication in the other direction, from the sensory receptors to the central nervous system. For motion control, the motor (efferent) pathway is essential. The sensory (afferent) pathway is particularly important for learning motor skills and dexterous tasks, such as typing or playing a musical instrument. A BCI offers an alternative to natural communication and control. A BCI is an artificial system that bypasses the body's normal efferent pathways, which are the neuromuscular output channels [2]. Instead of depending on peripheral nerves and muscles, a BCI directly measures brain activity associated with the user's intent and translates the recorded brain activity into corresponding control signals for BCI applications. This translation involves signal processing and pattern recognition, which is typically done by a computer. Since the measured activity originates directly from the brain and not from the peripheral systems or muscles, the system is called a Brain-Computer Interface. A BCI must have four components. It must record activity directly from the brain (invasively or non-invasively). It must provide feedback to the user, and must do so in real-time. Finally, the system must rely on intentional control. That is, the user must choose to perform a mental task whenever s/he wants to accomplish

a goal with the BCI. Devices that only passively detect changes in brain activity that occur without any intent, such as EEG activity associated with workload, arousal, or sleep, are not BCIs

II. LITERATURE REVIEW

- [1] This dataset contains data from 3 normal subjects during 10 sessions having 6 trials each. The subject sat in a reclining chair facing a video screen and was asked to remain motionless during performance.
- [2] Scalp electrodes recorded 64 channels of EEG, each referred to an electrode on the right ear (amplification 20,000; band-pass 0.1-60 Hz). All 64 channels were digitized at 160 Hz and stored.
- [3] The subjects used mu or beta rhythm amplitude (i.e., frequencies between 8-12 Hz or 18-24 Hz, respectively) to control vertical cursor movement toward the vertical position of a target located at the right edge of the video screen.
- [4] Data were collected from each subject for 10 sessions of 30 min each. Each session consisted of six runs, separated by one-minute breaks, and each run consisted of about 32 individual trials. Each trial began with a 1-s period during which the screen was blank.
- [5] The target appeared at one of four possible positions on the right edge. One sec later, a cursor appeared at the middle of the left edge of the screen and started traveling across the screen from left to right at a constant speed.
- [6] Its vertical position was controlled by the subject's EEG (update rate: 10 times per sec). The subject's goal was to move the cursor to the height of the correct target. When the cursor reached the right edge, the screen went blank. This event signaled the end of the trial.

III. PROPOSED SYSTEM

The EEG signals have been used for mental task classification, however the EEG signals are often corrupted by power line interference noise and EMC induced noise. These artifacts strongly influence the utility of recorded EEGs and need to be removed for better classification of mental task. Therefore the signals were preprocessed and then used to extract the feature.

The EEG signals are obtained from B-Alert experimental setup for three subjects and also from BCI data base (BCI Competition IIa data set for three subjects). Then the different PSD methods have been employed for feature extraction. The final step involves classification of mental task which has been done by using neural network based on Back Propagation Algorithm.

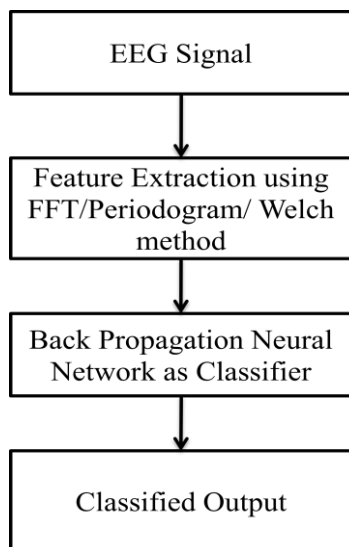

Fig 1: Proposed system

The EEG data required for classification can be obtained from data base which can record using EEG machine. We have also recorded the EEG data using B-Alert x64 rms standard system.

RESULT

In this work 1-D movement from left to right on screen has been classified using Back propagation neural network with one hidden layer, whereas the feature is extracted using FFT method, PSD, and Welch Method. The different result i.e. classification accuracy has been obtained as shown in table below.

Sr. No.	No. of hidden layers	Neurons in each layer	Wavelet Transform Method (dB6, Db5)	% Accuracy
1	1	6	dB5	100%

Table1. Results using neural network

While training the neural network performance and training plots are obtained shown in fig. Below.

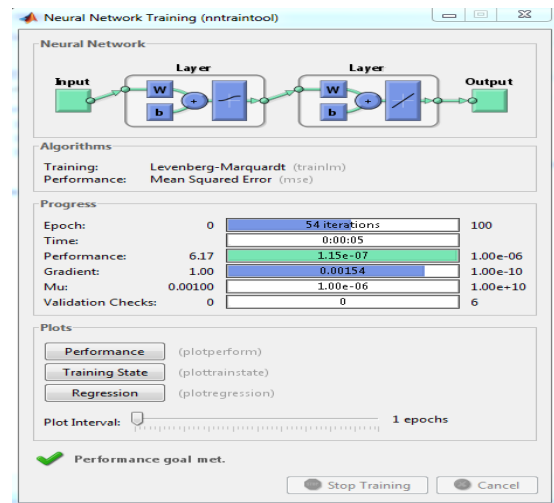

Fig 2: Training of Neural Network

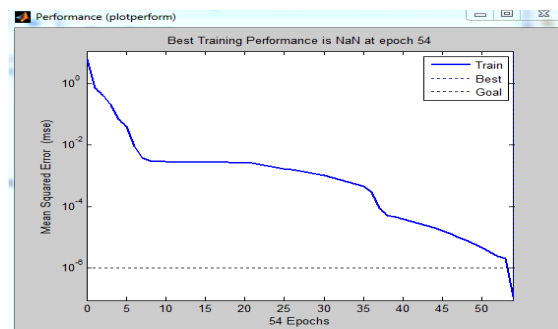

Fig 3: Performance plot of ANN with periodogram

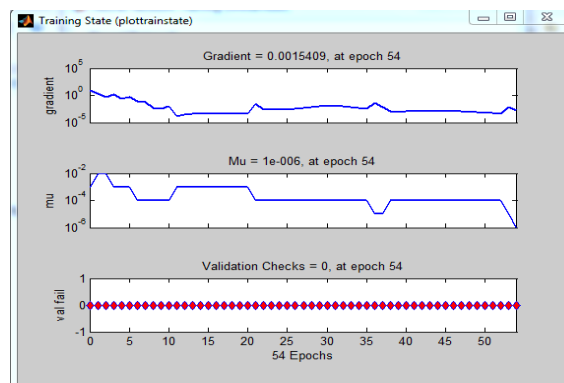

Fig 4: Training state plot of ANN with periodogram

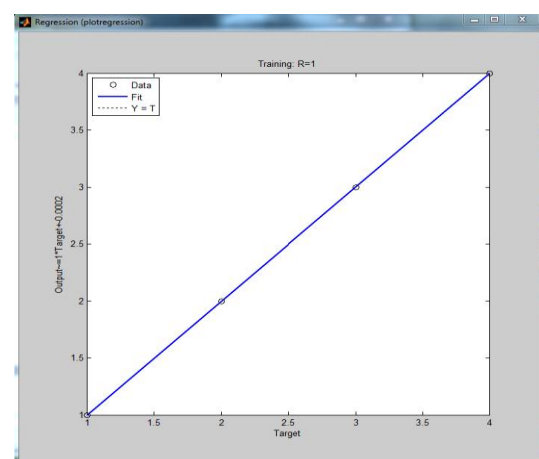

Fig 5: Regression state plot of ANN

IV. CONCLUSION

In this work the EEG data has been recorded on three subjects, for imaginary left to right movement. The subjects were imagine the cursor is moving from left to right top of screen. Data were collected from each subject for 10 sessions of 30 min each with sampling frequency of 120 Hz. X-64 Standard system is a sixty four channels system is used. The mental tasks have been classified using artificial neural network. Back propagation algorithm is used for classification, whereas the different PSD methods have been employed for feature extraction.

The 1-D from left to right top of screen movement have been taken and feature is extracted using PSD estimate such as FFT method periodogram and Welch method with and without windowing the data, in FFT method three overlays are taken with 50% overlap, each overlay has 120 samples i.e. $N=120$ and FFT is calculated in the frequency band of 8 to 30Hz with a frequency resolution of 2 Hz which gives the 12 PSD components for each channel thus total 96 PSD components are obtained for 16 channels, the PSD is also calculated in the same manner using periodogram and Welch method with and without windowing the data and classification is done with the help of neural network with one hidden layer and it is found that the classification accuracy for 1-D imaginary movement is increased up to 100%.

The classification accuracy has been calculated with different number of layers in neural network and different number of neurons in each layer the for 1-D movement as shown in table 2. It can be seen from table 2 that the on an average the classification accuracy increases with one hidden layer and neuron in the neural network. The comparative result for imaginary movement is given in the table 2 and it is found that the classification accuracy is found to be better with neural network as a classifier.

The PSD is calculated using FFT Method, periodogram method, and Welch method, most of time the classification accuracy found to be more if the Welch method is used to extract the feature, but PSD using FFT method with overlap and Welch almost perform similar.

The data windowing technique is also been employed in feature extraction, and we obtained better accuracy.

V. FUTURE SCOPE

In this work the 1-D movement of cursor from left to right have been classified using Back propagation neural network. The work may be extended to classify 2-D movement of cursor. Also the optimization techniques such as PSO, ACO can be used to optimize the results; finally the classified output can be used to control the cursor movement on pc for paralyzed and rehabilitated patient, or other devices.

REFERENCES

[1] Yun Fu and Thomas S. Huang, "hMouse: Head Tracking Driven Virtual Computer Mouse," IEEE Workshop on Applications of Computer Vision, no. 0-7695-2794-9/07, 2007.
[2] Dan Ionescu, "Gesture Control and the New and Intelligent Man-Machine Interface," IEEE International Symposium on Applied Computational Intelligence and Informatics, no. 6th, May 2011.

[3] Caterina Cinel, Luca Citi, and Riccardo Poli Mathew Salvaris, "Novel Protocols for P300-Based Brain-Computer Interfaces," IEEE Transactions on Neural Systems And Rehabilitation Engineering, vol. 20, pp. 8-17, January 2012.
[4] Yuhuan Zhu, Hongzhi Qi, Baikun Wan, Yong Hu & KDK Luk Dong Ming, "Study on EEG-Based Mouse System by Using Brain-Computer Interface," International Conference on Virtual Environments, Human-Computer Interfaces and Measurements Systems, May 2009.
[5] Douglas J. Weber, Zhi-Hong Mao, Jennifer L. Collinger, Alan D. Degenhart, John W. Kelly, Michael L. Boninger, Elizabeth C. Tyler-Kabara, and Wei Wang Ramana Vinjamuri, "Toward Synergy-Based Brain-Machine Interfaces," IEEE Transactions on Information Technology in Biomedicine, vol. 15, pp. 726-736, September 2011.
[6] Amy L. Orsborn, Karunesh Ganguly, and Jose M. Carmena Rodolphe Héliot, "System Architecture for Stiffness Control in Brain-Machine Interfaces," IEEE TRANSACTIONS ON SYSTEMS, MAN, AND CYBERNETICS—PART A: SYSTEMS AND HUMANS, vol. 40, no. 4, pp. 732-742, July 2010.
[7] Roberto Battiti and Andrea Passerini, "Brain-Computer Evolutionary Multiobjective Optimization: A Genetic Algorithm Adapting to the Decision Maker," IEEE TRANSACTIONS ON EVOLUTIONARY COMPUTATION, vol. 14, no. 05, pp. 671-687, OCTOBER 2010.
[8] F. di Pierro, K. Soon-Thiam, and D. Savic, "An investigation on preference order ranking scheme for multiobjective evolutionary optimization," IEEE Trans. Evol. Computat., vol. 11, no. 1, pp. 17-45, Feb. 2007.
[9] C.-C. Postelnicu and D. Talaba, "P300-Based Brain-Neuronal Computer Interaction for Spelling Applications," IEEE TRANSACTIONS ON BIOMEDICAL ENGINEERING, vol. 60, no. 2, pp. 534-543, FEBRUARY 2013.
[10] Yaming Xu* and Yoshikazu Nakajima, "A Two-Level Predictive Event-Related Potential-Based Brain-Computer Interface," IEEE TRANSACTIONS ON BIOMEDICAL ENGINEERING, vol. 60, no. 10, pp. 2839-2847, OCTOBER 2013.
[11] Xin-an Fan, Ke Jie, Teng Teng, Hongsheng Ding, and Yili Liu Luzheng Bi, "Using a Head-up Display-Based Steady-State Visually Evoked Potential Brain-Computer Interface to Control a Simulated Vehicle," IEEE TRANSACTIONS ON INTELLIGENT TRANSPORTATION SYSTEMS, vol. 15, no. 3, pp. 959-966, June 2014.
[12] Edmund C. Lalor, Ciarán Finucane, Gary McDarby, and Richard B. Reilly Simon P. Kelly*, "Visual Spatial Attention Control in an Independent Brain-Computer Interface," IEEE TRANSACTIONS ON BIOMEDICAL ENGINEERING, vol. 52, no. 9, pp. 1588-1596, SEPTEMBER 2005.
[13] Niels Birbaumer, Dennis J. McFarland, Gert Pfurtscheller and Theresa M. Vaughana Jonathan R. Wolpaw, "Brain-computer interfaces for communication and control," Clinical Neurophysiology, vol. 113, pp. 767-791, March 2002.
[14] T. M. Vaughan, D. J. McFarland, and J. R. Wolpaw H. Sheikh, "EEGbased brain-computer interface (BCI) communication Comparison of alternative signal processing methods for time-domain EEG activity," Social Neuroscience Abstract, vol. 27, p. 168, 2001.
[15] D. Xu, M. Cheng, and S. Gao X. Gao, "A BCI-based environmental controller for the motion-disabled," IEEE Transaction on Neural System Rehabilitation Engineering, vol. 11, no. 02, pp. 137-140, June 2003.