

# Vehicle Radiation Monitor

Nilesh Kunte<sup>1</sup>, Shashank Khandve<sup>2</sup>, Tejas Mundhe<sup>3</sup>, P.V. Sontakke<sup>4</sup>

Department of ENTC, PCCOE, Savitribai Phule Pune University<sup>1, 2, 3</sup>

Assistant Professor, Department of ENTC, PCCOE, Savitribai Phule Pune University<sup>4</sup>

**Abstract:** The primary objects of the present project to provide a novel means for safely detecting any malfunction of a pressurized Radiation system in order to prevent accumulation of combustible radiation so that damage or explosion due to such an accumulation of Radiation is prevented. Another object of the present invention is to provide a novel safety means for detecting the Radiation of rays into the area of an appliance when the appliance is in a shutdown condition and not in operation. The main objective of VRM is Vehicle radiation monitor (VRM) is a wall mountable unit which measures the Gamma field at the detector (Plastic-Scintillator). The Vehicle Radiation Monitor is intended to measure the radioactivity that may be present in the vehicles entering /leaving the nuclear installation. An Alarm is to be generated when the detected activity is higher than a set permissible value.

**Keywords:** Gama radiation; Plastic Scintillator; AluminiumIP-67 protection; Vehicle Radiation Monitor (VRM); Signal Processing Unit (SPU); Remote Display & Alarm indication Panel (RDAP).

## I. INTRODUCTION

### 1.1 Problem Definition

The Vehicle Radiation Monitor is intended to measure the radioactivity that may be present in the vehicles entering / leaving the nuclear installation.

An Alarm is to be generated when the detected activity is higher than a set permissible value. The block diagram of the system is shown in fig .1 below.

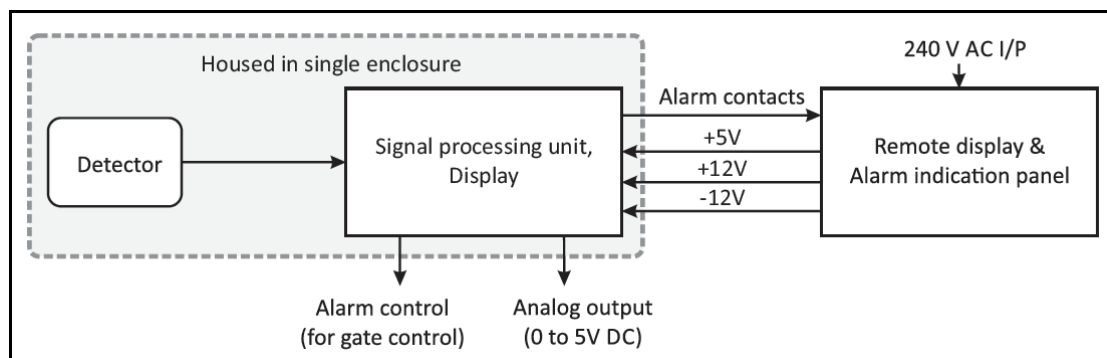

Figure 1.1: Vehicle Radiation Monitor

The system generates an alarm when the ambient radiation around the detector exceeds a pre-set limit. The system consists of:

1. Radiation detector
2. Signal Processing Unit (SPU)
3. Remote Display & Alarm indication Panel (RDAP)

The Detector and SPU are mounted inside an enclosure (IP-67 protection) with required connectors and RED/GREEN LED dome lamps and shielding.

#### 1. Radiation Detector

plastic scintillator (1 meter long ,50 mm diameter) with integral Photo Multiplier Tube is used as detector for measuring radiation. The sensitivity of the detector is to such that it should generate alarm when a source of 1 $\mu$ Ci for Co<sup>60</sup> or 2.5 $\mu$ Ci for Cs<sup>137</sup> are present for a maximum time of 2 seconds at a radius of 0.5 meters around detector at ambient background of 0.10 $\mu$ Sv/h and 4 $\mu$ Ci Co-60 at 1.25 meter

The detector is powered by  $\pm 12V$  generated by Signal Processing Unit and has in-built HV circuitry and preamplifier. The pre-amplified pulse and sample HV signal are connected to the Signal Processing Unit (SPU). The sample HV signal is used for measuring the HV applied to detector and generating an alarm when the HV falls below a set limit.

#### 2. Signal Processing Unit (SPU)

The signals from detector are processed by Signal Processing Unit (SPU). It consists of a detector signal processing circuit, microcontroller, High voltage and the function of SPU are:

a) Receives the voltage pulse from Detector and amplifies and process the pulse to a semi Gaussian shape. A discriminator compares the shape pulse with a present threshold value and a TTL signal is generated when the pulse amplitude exceeds the threshold (for rejecting noise and other unwanted signals).The TTL pulse count rate is proportional to radiation.

- b) The microcontroller is used for measuring the frequency and display it on a 2 line 16 character LCD display.
  - c) Generate 0-5V DC signal proportional to frequency of 0 to 1000 CPS.
  - d) Generate an alarm when the count rate exceeds a present value (adjustable by a key Pad) and transmit the same to RDAP.
  - e) Light a RED LED lamp and de-energize two relays for following alarm conditions:
    1. Count Rate computed exceeds the present limit.
    2. Latch the indication until a acknowledge signal from RADP signal is received and when the acknowledge signal is received.
  - f) Light a Green LED lamp when there are no alarm conditions and when count rate high alarm condition is not latched.
  - g) Output the alarm relay contacts for GATE control and also to RADP.
  - h) Receives required DC voltages (+5V, +12V,-12V) for operation from RADP.
3. Remote Display & Alarm indication Panel (RADP)
4. The RADP receives the signals from SPU and consists of the following:
- a) Receive the Alarm contacts from SPU and latch the alarm condition and indicate through LED lamp and also activate audio hooter.
  - b) RESET switch to reset the hooter.
  - c) Light a green lamp when there is no alarm condition.
  - d) ACKNOWLEDGE switch and transmit the contacts to SPU.
  - e) Receive 240V AC and generate the required signals for operation.
  - f) Generated DC voltages (+5V,+12V,-12V) and transmit it to SPU for its operation.

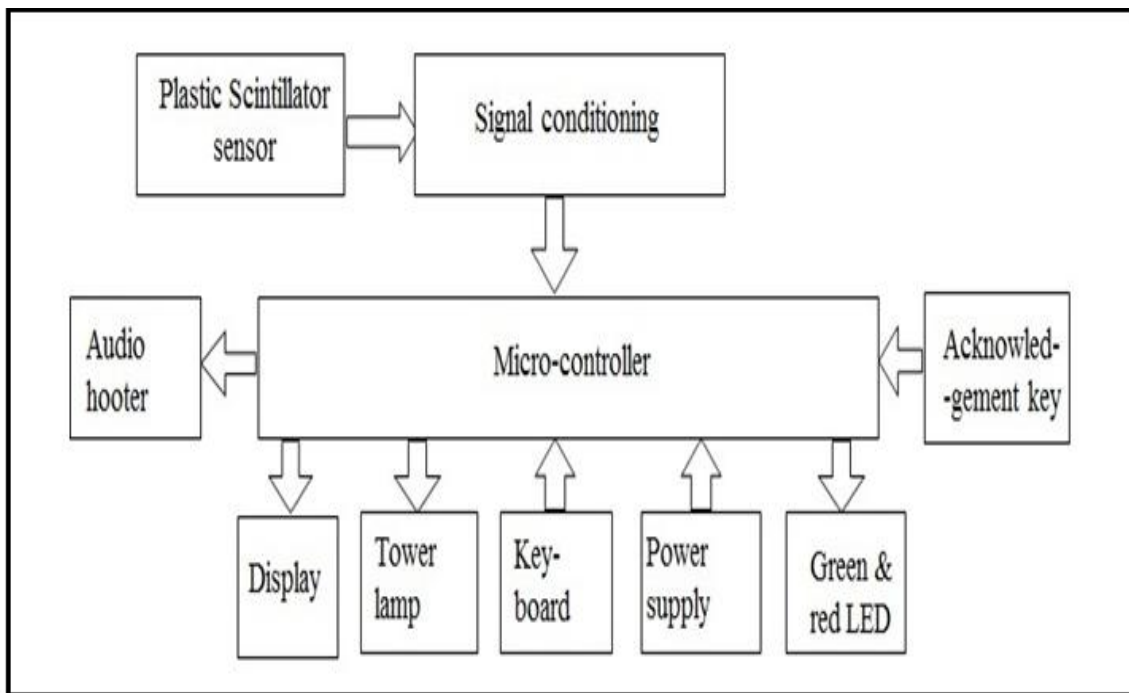

Figure 1.2: Complete block diagram of the system

## II. RELATED WORK

1. A number of strategic tools are used in the detection of radiation such as radiation portal monitoring equipment, personal radiation detectors, hand held detectors and x-rays systems for imaging of shielding. Radiation detection systems can be passive or active. Passive systems for detection of radiation include radiation portal monitoring equipment, mobile systems, hand held, backpack and belt monitoring systems, all of which have been deployed. Mobile x-ray and fixed systems have been used for penetration of cargo containers for suspected cargo. Plutonium and a few other radioactive materials emit neutron and tus neutrons are of particular interest in detection applications at border crossing [1].
2. Energy based alarm algorithms with enhanced sensitivity over gross counting have been implemented for radiation portal monitoring equipment. The energy information obtained from plastic scintillators can be used to distinguish between naturally occurring radioactive material and special nuclear material. The energy based algorithm was considered to be a much desired improvement in detection over gross count algorithms. One of the main limitations of radiation portal monitoring systems is the presence of naturally occurring radioactive isotopes that can present a significant operational challenge [1,3].

3. Radiation portal monitoring equipment has been deployed for border crossing and port application in detection of illicit nuclear material. Detectors of gamma rays based on polyvinyl toluene (PVT) and thallium doped crystalline sodium iodide have been demonstrated and deployed. For passive screening of gamma rays, the energy range of interest for detection was between 20 keV to 3 MeV [2].

4. The use of nanoscale materials for detection of radiation is expected to overcome single crystal based detectors

limitations such as size and cooling requirements to very low temperatures. Nanophosphor has been mentioned as a candidate material for scintillators and detectors. Cerium doped lanthanum halides (less than 10nm in diameter) have also been mentioned as suitable candidates for scintillators nanocomposites. Due to their brightness and short decay lifetime they are very effective in gamma ray detection. Scaling up of the synthesis of cerium lanthanum fluoride to kilogram quantities remains a further research challenge that remains to be addressed [4].

**III.FLOW CHART OF THE SYSTEM**

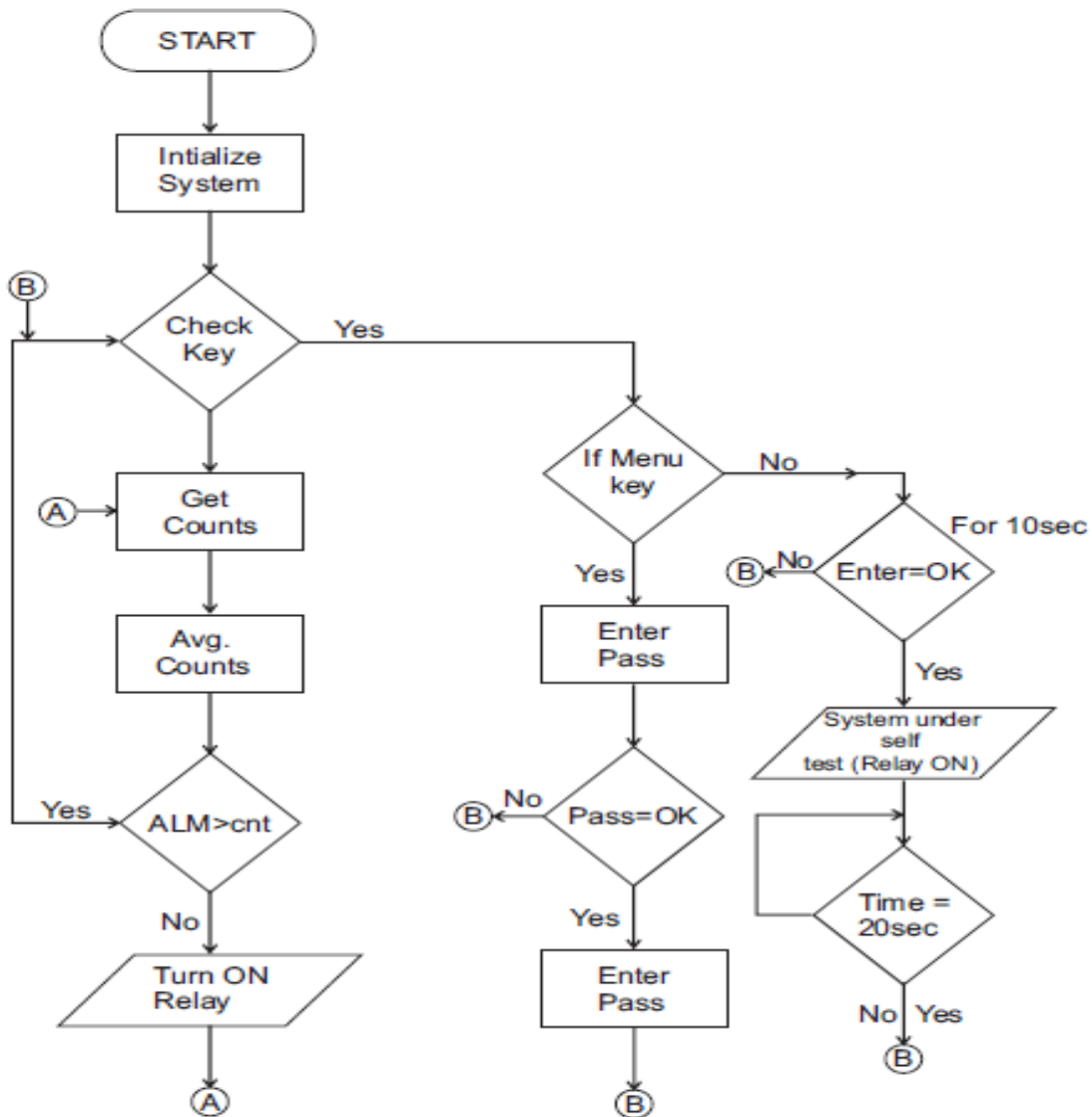

Flow Chart1

Description of flow chart:

- I. System initialization
- II. Acknowledgement key check, if yes then check IV. menu key if yes then enter pass code, if no, then wait for 10 seconds and enter ok. It will display “System under self test.”
- III. If acknowledgement key is set the system will show results of the radiation detection as get count, alarm count, average count then it will turn on delay. After detecting radiation alarm will be generated and red light will glow.
- V. To re set the system acknowledgement key need to press.

IV.SIMULATION RESULTS

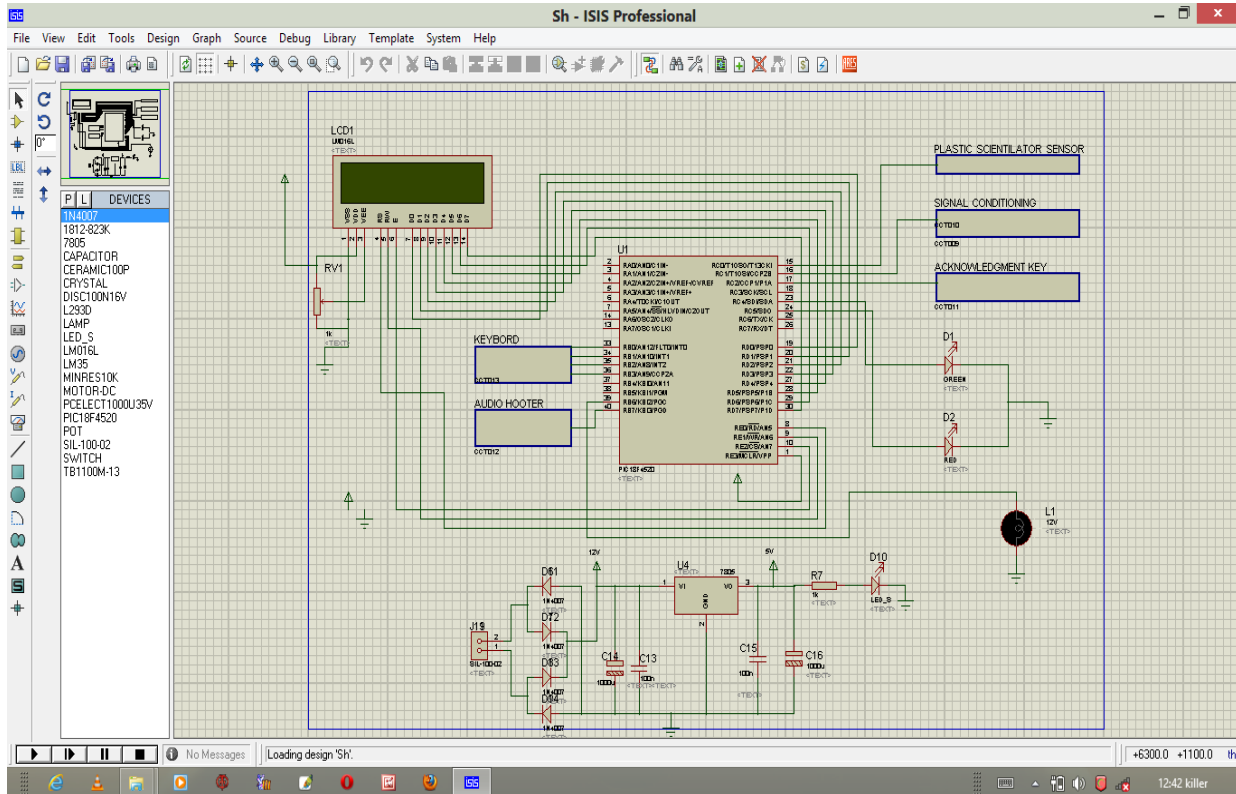

4.1 Overall system circuit diagram Vehicle Radiation Monitor

V. CONCLUSION AND FUTURE WORK

REFERENCES

- 1) A cost-effective Vehicle Radiation Monitor (VRM) is proposed, designed and successfully implemented as a laboratory prototype, which is presented in this paper. The practical testing of the system is done using plastic-scintillator, which forms an ingredient of VRM.
  - 2) The test results confirm the efficient operation of the prototype by detecting low and high gas Radiation levels and alerts the users by issuing appropriate audio-visual warning signals like gamma rays. The proposed system is designed to meet UK occupational health and safety standards with respect to Vehicle radiation monitor (VRM) in residential and commercial premises.
  - 3) The cost involved in developing the system is significantly low and is much less than the cost of radiation monitoring commercially available in the market.
  - 4) This system can be upgrade by using the sensors which detects different types of radiations.
  - 5) In this system we can use new technologies for wireless communication with control room, for high speed communication.
  - 6) The system can be upgrade to display some radiation parameters such as Intensity of radiation, type of radiation, area covered by radiation.
  - 7) VRM can be made mobile for now it is designed for static installation.
- [1] R. Kouzes, J. Ely, R. Hansen, J. Scheppe, E. Siciliano, D. Stromswold, "Homeland Security Instrumentation For Radiation Detection At Borders," in Forth American Nuclear Society International Topical Meeting on Nuclear Plant Instrumentation, Controls and Human-Machine Interface Columbus, Ohio, September, 2004
  - [2] S. S. Nafee, and M. I. Abbas, "A theoretical approach to calibrate radiation portal monitor (RPM) systems," Applied Radiation and Isotopes, vol. 66, pp. 1474-1477, October 2008.
  - [3] B.D. Geelhood, J.H. Ely, R.R. Hansen, R.T. Kouzes, J.E. Scheppe, R.A. Warner, "Overview of Portal Monitoring at Border Crossings," Nuclear Science Symposium Conference Record, IEEE Volume 1, 19-25 Oct. 2003 Page(s):513 – 517, 2003.
  - [4] Los Alamos National Laboratory, "Development of nanocomposite scintillators," Spring 2007