

# Efficient Quality Analysis and Enhancement of MRI Image Using Pre-Processing Techniques

Anusree J<sup>1</sup>, R.S. Moni<sup>2</sup>

PG Student, Dept of Electronics and Communication Engineering, Marian Engineering College, Trivandrum, India<sup>1</sup>

Professor, Dept of Electronics and Communication Engineering, Marian Engineering College, Trivandrum, India<sup>2</sup>

**Abstract:** Real time applications require improved image quality which is achieved efficiently using pre-processing techniques. For this purpose, neighbourhood pixels in input image are used so that desired output image is obtained. The quality of medical image is determined by the major parameters- Noise and Resolution. Filtration and Resolution Enhancement are employed to process the medical image. The main objective of this paper is to improve image quality by de-noising and resolution enhancement for different types of noises. Medical image is mostly degraded by noise. For preserving the edges and contour information of the MRI, an efficient de-noising and improved image enhancement technique is to be employed. Filtration is performed using average, median and wiener filters and an interpolation based Discrete Wavelet Transform (DWT) performs resolution enhancement. Performance evaluation is done using Peak Signal to Noise Ratio (PSNR). From the statistical measures and image quality, it is clear that de-noising and resolution enhancement is inevitable for pre-processing.

**Keywords:** De-noising, Discrete Wavelet Transform, Filtering, Image pre-processing, PSNR.

## I. INTRODUCTION

Magnetic Resonance Imaging (MRI) is a test which makes use of magnetic field and pulses of radio wave energy to make pictures of organs and structures in the body. In many cases, MRI gives better information about structures in the body than can be seen with an ultrasound scan or CT (computed tomography), X-ray scan. MRI is an imaging technique used in radiology for visualizing the internal structure of tissues and organs in the body in detail especially for imaging soft tissues MRI does not use any radiations. The magnet used in MRI may affect artificial limbs, pacemakers, and other medical devices that contain iron even affecting a watch that is close to it. Therefore, patients with simulated heart valves, metallic ear implants, chemotherapy, insulin pumps, bullet fragments etc should not have to do MRI scanning. MRI provides better image quality for the brain, the muscles, the heart and cancerous tissues compared with other medical imaging techniques such as computed tomography (CT) or X-rays [1].

Brain tumour is caused due to abnormal cell growth within the brain and is mainly caused by radiation to the head, genetic risk factor, HIV infection, cigarette smoking and also due to environmental toxins. Brain tumour detection is complicated due to the complex structure of brain. Major problem in image segmentation is inaccurate diagnosis of the tumour region which gets minimised mainly due to the contrast, blur, noise, artefacts, and distortion. Noisy MR image prevents accurate detection of tumour. Even small amount of noise can change the classification. So the noise is reduced using de-noising technique [2].

For improving the quality of image, filters have to be applied. There are different types of filters to denoise the

image like Mean filter, Median filter and Wiener filter. Mean filter [3] is a type of linear spatial filter. Mean filter is basically a convolution filter which consists of mask or kernel to produce the smooth image. It is often used to reduce noise and also to reduce the amount of intensity variation from one pixel to another.

Median filtering is a nonlinear operation. It is like the mean filter but is better in reducing noise without blurring edges of the image that is the preservation of sharp edges. The median value [4] computed from the neighbourhood pixels and will not affect the other pixels significantly. Its response is based on the median value of pixels contained in the image area encompassed by the mask and then replaces the center value of pixel with the calculated median value.

Wiener filter performs noise reduction in an image by comparison with an estimation of the desired noiseless signal which is based on a statistical approach. Wiener filters are characterized by three important considerations. 1) Assumption: The stationary linear stochastic processes of image and noise along with known spectral characteristics or known autocorrelation and cross-correlation 2) Requirement: the filter should be physically realizable/ causal 3) Performance criterion: minimum mean-square error (MMSE). [5]

Image Resolution is always an issue in medical image processing, namely loss of quality at the image edges. Resolution enhancement is applied to preserve the edges and contour information. Image interpolation is defined as the process of changing image from one resolution to another without losing quality of image. Interpolation of an image is the way through which images are improved.

The image resolution enhancement method using Discrete Wavelet Transform (DWT) is giving better results than any other technique.

Accurate detection of tumour in noisy MRI is impossible. Even a small amount of noise affects diagnosis [6]. MRI gets affected by different noises as most of the imaging techniques are degraded by noise. Noise and resolution being the major medical image quality parameters; it is inevitable to improve the MRI quality by de-noising and resolution enhancement for better diagnosis.

## II. LITERATURE REVIEW

The concept of MRI was proposed by Damadian in the year of 1969. Damadian's first article on his work was published in March 1971. Damadian also proposed scanning method for MRI in 1971. Damadian, Minkoff and Goldsmith, achieved the first scan (image) of the human body on 1977.

**Mona Mahmudi, Guillermo Shapiro, "Fast Image and Video Denoising via Non-Local Means of similar neighbourhood" [2005]** had made improvements to the nonlocal means of image denoising method. In the original non-local method a noisy pixel is replaced by the weighted average of pixels with correlated adjacent neighbourhoods. While analysing denoising results up-to-date, they concluded that this method is computationally unrealistic. They introduced filters that eliminate unrelated neighbourhoods from the weighted average in order to accelerate the algorithm. These filters depends on the local average gray values and gradients, then neighbourhoods are reclassified and thereby the original quadratic complexity is reduced to a linear one. It also facilitates the reduction of the influence of less-related areas in the denoising of a wanted pixel. They presented the underlying framework and experimental results for gray level images, colour images as well as for video [7].

**L. Sahawneh, B. Carroll, "Stochastic Image Denoising using Minimum Mean Squared Error (Wiener) Filtering," [2009]** explored the derivation of inverse filter and Wiener filter in restoring noisy images and histogram estimation. When the point spread function is known in the absence of noise, the inverse filter functions well. The Wiener filter approximates the original image better by attenuating frequencies with poor SNR that dominated the image produced by the inverse filter. The Wiener filter also gives better performance for Gaussian blur and uniformly distributed noise which require knowledge of original spectrum which is practically difficult. Therefore Wiener filter is poor in many practical applications but provides a sound theoretical foundation upon which other restoration techniques are based [8].

**Jianhua Luo, Yuemin Zhu, and Isabelle E. Magnin, "Denoising by Averaging Reconstructed Images: Application to Magnetic Resonance Images [2009]** proposed a novel denoising approach which is based on averaging the reconstructed images. This approach divides the image spectrum to be denoised into various parts.

Using a 2D singularity function analysis model, every sub spectrum is then reconstructed by an image. Each of the reconstructed images are collected as a sum of the different smaller noise and in the same noise free image, the denoising is obtained through averaging the reconstructed images.

It is demonstrated that results apply for both simulated and real images consistently, the proposed approach can efficiently denoise high quality image depicts significant advantages over conventional denoising methods [9].

**Ning Chun-yu, liuShu-fen, QU Ming, "Research on removing noise in medical image based on median filter method," [2009]** proposed two methods that use traditional median filter and an adaptive median filter for removing salt-and-pepper noise in medical images. The influence of the filter window size and the spatial density of noise on the quality of denoised image analysis are also done. The simulation results based on Matlab show that the two methods can eliminate the salt-and-pepper noise in MRI and CT medical images and the edges and detail information of the entity is preserved. Both of these methods have been used in the virtual endoscope system, and the filtering performance is very satisfactory [10].

**Zeinab A. Mustafa and Banazier A. Abraham, "K11. Modified Hybrid Median Filter for Image De-noising" [2012]** the problem of Gaussian noise removal while keeping the integrity of relevant image information is a critical issue in image restoration. Accurate diagnosis becomes impossible due to noisy MRI by reducing resolution and contrast. For these reasons, denoising methods are applied to increase the SNR and improve image quality. They proposed a modified version of Hybrid Median filter for noise reduction, which is a statistical filter, to compute the median of the diagonal elements and the mean of the diagonal, vertical and horizontal elements in a moving window and finally the median value of the two values will be the new pixel value. Their proposed method outperforms the classical implementation with better quality evaluation metrics and retains the structural details. It not only removes speckles but also preserves the details and edges of the image. It is better than all other methods in quantitative terms as well as visual quality of the image [11].

**Gurmeet Kaur and Jagroop Singh "Performance Evaluation of various Image De-noising Techniques" [2012]** said that the process of denoising is challenging for researchers. Even though there are several algorithms each has its assumptions, merits, and demerits. The prime focus is related to the pre-processing of an image before it can be used in applications which are done by de-noising of image. The de-noising algorithms, filtering approach and wavelet based approach are used and comparative study is performed. Different noises like Gaussian, salt and pepper and speckle noise are used. In de-noising images corrupted with Gaussian, salt and pepper and speckle noise, the wavelet based approach has been proved to be the best. The comparison using quantitative measure is provided by

the parameters like Entropy, Correlation, Peak signal to noise ratio, Root mean square error of the image [12].

**ToranLal Sahu1 “A Survey on Image Noises and Denoise Techniques” [2012]** Environmental disturbances make digital images noisy. The quality of an image is ensured by image pre-processing by noise reduction is an inevitable step before analysing or using images. Data values acquired by image sensors generally contain noise. The image de-noising is a serious task for medical imaging, satellite and areal image processing, space exploring, micro vision systems, robot vision etc. The noise is distinguished by its pattern and by its probabilistic characteristics. Even though wide variety of noise types is focussed, the purpose of denoising filters that have been developed is to reduce noise from corrupted images and to enhance image quality [13].

### III. OVERVIEW OF PROPOSED WORK

The image quality analysis consists of two major parts one is mainly denoising and the other one is resolution enhancement. The initial part of the entire system is denoising part. Denoising is again having two parts one is pre-processing the MRI image and the second one is filtration part to reduce the noise which is in the MRI image.

#### A. Denoising Mechanism

The image is pre-processed using denoising to extract the useful information because most of the imaging techniques are degraded by noise. To analyse the medical image i.e. segmentation of brain, initially the noise should be removed from the MRI image so as to retain the original information.

#### B. Gaussian Noise

Gaussian noise is independent at each pixel as well as independent of the signal intensity. Gaussian noise is statistical noise which has its probability density function equal to that of the normal distribution, known as the Gaussian distribution. In other words, the values that this noise can take on are Gaussian-distributed. The Gaussian noise is evenly distributed over the signal. This means that each pixel in the noisy image is the sum of the true pixel value and a random Gaussian distributed noise value. The mean (average) and variance (standard deviation) are defining factors of Gaussian noise. The frequency spectrum of Gaussian noise after a fourier transform has a bell-shape curve and is symmetric around the mean. For evaluation the performance of the MRI brain image, Gaussian noise is added to the image and filtered using noise filters. Each pixel in the noisy image contains true pixel value as well as random Gaussian distribution.

$$f(x) = \frac{1}{\sigma\sqrt{2\pi}} \cdot e^{-\frac{1}{2} \left(\frac{x - \mu}{\sigma}\right)^2}$$

$\mu$  is the mean of average value of  $x$ , and  $\sigma$  is its standard deviation.

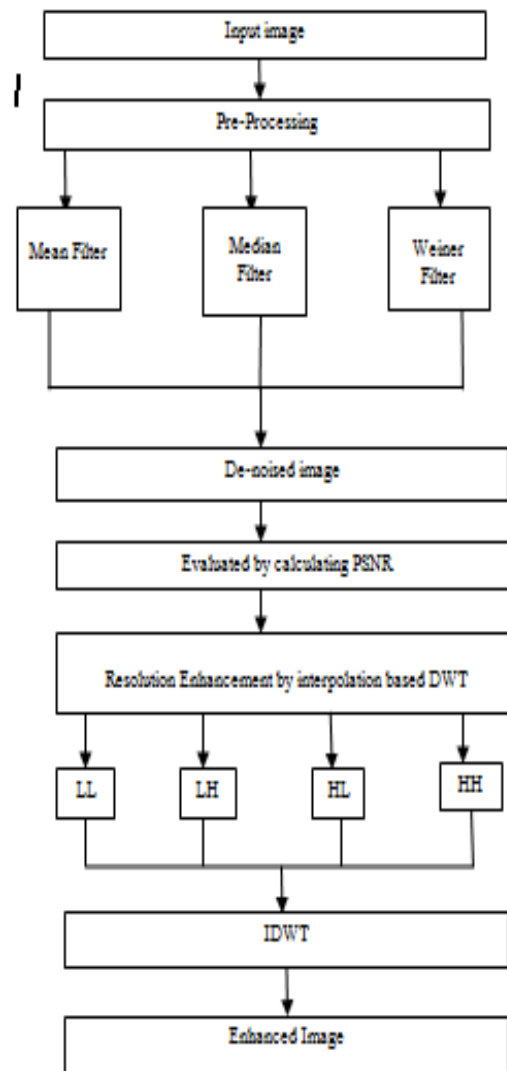

Fig1.blockdiagram of proposed method

#### C. Salt and Pepper Noise

Salt and pepper noise is also called as an impulse noise or as intensity spikes. It is a generalized form of noise typically seen in images. As per image criteria, the noise represents itself as randomly occurring white and black pixels. An image containing impulse noise will have dark pixels in bright regions and bright pixels in dark regions. The salt and pepper noise is mainly obtained while transmitting data which has only two possible values, 0 and 1. The probability of each value is typically less than 0.1. The corrupted pixel values are set alternatively to the maximum or to the minimum value, giving the image a “salt and pepper” like appearance as salt looks like white(one) and pepper looks as black(zero) for binary images. Pixels which are unaffected by noise remain unchanged. This noise is usually caused in digitization process due to timing errors, malfunctioning of pixel elements in the camera sensors, faulty memory locations etc.

#### D. Speckle Noise

Speckle Noise is multiplicative in nature. It is a granular noise and increases the mean grey level of a local area.

This is mainly due to coherent processing of backscattered signals from multiple distributed targets. Locally correlated multiplicative noises from small scatterers corrupt ultrasound image. These noises are commonly called “speckles”.

#### E. Averaging Filter

Mean filtering is a linear filtering scheme. It is also known as averaging filter. This filter applies mask over each pixel in the signal. Each of the components of the pixels comes under the mask are being averaged together to form a single pixel that's why the filter is also known as average filter. Edge preserving criteria is poor in this filter.

A mean filter performs smoothing on an image. i.e., it reduces the variation in terms of intensity between adjacent pixels. The mean filter is a simple moving window spatial filter because it replaces the center value in the window with the average of all the neighbouring pixel values including that centre value. It is implemented with a convolution mask, which provides a result that is a weighted sum of the values of a pixel and its neighbour pixels. The mask is a square. Generally a  $3 \times 3$  square kernel is used. If the sum of coefficients of the mask equal to one, then the average brightness of the image remains unchanged. If the sum of the coefficients equal to zero, a dark image will be returned by the mean filter. This average filter works on the shift-multiply-sum principle.

If all the weights of the filter are same then it is known as constant weight filter and if the sum of coefficients of the mask equal to one, then the average brightness of the image will not be changed. If the sum of the coefficients equal to zero, the average brightness is lost, and a dark image will be returned.

The image is more blurred for larger kernels of size  $5 \times 5$  or  $7 \times 7$  and produces better de-noising. A trade off is to be maintained between the kernel size and the amount of de-noising

#### F. Median Filter

The median filter is used to reduce noise in an image, somewhat like the mean filter. However, it often does a better job than the mean filter of preserving useful detail in the image. A median filter comes under the category of nonlinear filter. Like mean filter, it also follows the moving window principle. A  $3 \times 3$ ,  $5 \times 5$ , or  $7 \times 7$  mask of pixels is moved over the entire image. Initially, the median of the pixel values in the window is computed, and then the center pixel of the window is replaced by the computed median value. Median is calculated by first sorting all the pixel values from the surrounding neighbourhood (either ascending or descending order) and then the pixel is replaced by the middle pixel value. The median is more robust when compared to the mean. This filter use the neighbour value or considered pixel as median and hence does not create new pixel values when the filter straddles an edge. It shows that median filter also preserves sharp edges than the mean filter.

#### G. Wiener Filter

The Wiener filter is a spatial-domain filter and it is generally used to suppress additive noise. In 1942, Norbert

Wiener proposed the concept of Wiener filtering. There are two methods:

- (i) Fourier-transform method (frequency-domain) and
- (ii) mean-squared method (spatial-domain)

for implementing Wiener filter. The fourier method is used for de-noising and deblurring. While the latter is used for de-noising. In Fourier transform method of Wiener filtering a priori knowledge of the noise power spectra and the original image is required. But in latter method no such a priori knowledge is required. Hence, it is easier to use the mean-squared method. Wiener filter is based on the least-squared principle, i.e. this filter minimizes the mean-squared error (MSE) between the actual output and the desired output.

In statistical theory, Wiener filtering is of great importance. It estimates the original data with minimum mean-squared error and hence, the overall noise power in the filtered output is minimal.

The Wiener filter approaches filtering in a different manner. One is assumed to have knowledge of the spectral properties of the original signal and the noise, and would seek the LTI filter whose output would come as close to the original signal as possible. Wiener filters are characterized by the following:

- a. Assumption: signal and (additive) noise are stationary linear random processes with known spectral characteristics.
- b. Requirement: the filter must be physically realizable, i.e. causal (this requirement can be dropped, resulting in a non-causal solution).
- c. Performance criteria: minimum mean-square error [14].

A Wiener filter requires an accurate noise model, which may be difficult to obtain in various practical cases. In addition, it involves much computational complexity.

#### H. Resolution Enhancement

One of the major issues in image processing is resolution. Resolution is the measure of the amount of detail information in the image. More image details are obtained from high resolution. Initially the image is pre-processed using de-noising which results in noise reduction and loss of quality at the image edges. Resolution enhancement preserves the edges and contour information of a filtered image. It is important to preserve the edges and contour information in order to segment an image accurately [15].

Resolution is the measures quality of a de-noised image. For enhancing the resolution of an image, an improved discrete wavelet transform is proposed which preserves the edges and the contour information. Peak Signal to Noise Ratio is used to measure the performance of resolution enhancement technique.

#### I. Discrete Wavelet Transform

Wavelets play a significant role in image processing. Wavelets are simply mathematical functions and these functions analyse data according to scale or resolution. They aid in studying a signal at different resolutions or in

different windows. Wavelet transforms enable the representation of images in terms of local spatial and frequency contents. The Discrete Wavelet Transform (DWT) of image signals produces a non-redundant image representation, which provides better spatial and spectral localization of image formation. [16]

In discrete wavelet transforms (DWT), the wavelets are discretely sampled for numerical analysis and functional analysis. The finite scale multiresolution representation of a discrete function can be known as a discrete wavelet transforms (DWT). It acquires both frequency and time information.



Fig 2: One level decomposition of DWT

DWT decomposes signals into sub-bands with smaller bandwidths and slower sample rates namely Low-Low (LL), Low-High (LH), High-Low (HL), and High- High (HH). i.e. from one level of transform four sub-bands are obtained– first low pass sub-band having the coarse approximation of the source image called LL sub-band, and three high pass sub-bands that exploit image details across different directions – HL for horizontal, LH for vertical and HH for diagonal details

The frequency components of those four sub-bands are interpolated to cover the full frequency spectrum of the original image. The interpolation technique is used to increase the number of pixels in an image. The high frequency sub-band of the image is interpolated to low frequency sub-bands of the image to give high resolution enhanced image.

The 2-D wavelet decomposition of an image is done by applying 1-D DWT along the rows of the image first, and then, the results are decomposed along the columns.

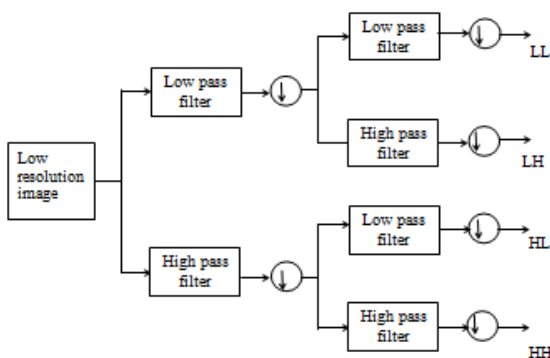

Fig 3. Block diagram of DWT

J. Inverse Discrete Wavelet Transform

Reconstruction is the process by which components can be assembled back into the original image without loss of information. An image is reconstructed from the approximation and detail coefficients derived from decomposition using Inverse Discrete Wavelet Transform

(IDWT). The performance of de-noised and enhanced image is evaluated by determining PSNR value

IV.QUALITY ANALYSIS

Peak signal-to-noise ratio (PSNR) is defined as the ratio between a signal's maximum power and the power of the signal's noise .PSNR is commonly used to measure the quality of reconstructed images that have been compressed. PSNR is usually expressed in decibels, which is a logarithmic scale. It is employed as an approximation to human perception of reconstruction quality, therefore in some cases one reconstruction may appear to be closer to the original than another, even though it has a lower PSNR (a higher PSNR would normally indicate that the reconstruction is of higher quality).

It is most easily defined using the mean squared error (MSE), where it denotes the mean square error for two m×n images I (i, j)& I (i, j) where one of the images is considered a noisy approximation of the other and is given by

$$MSE = \sum_{M,N} \left[ \frac{I_1(m,n) - I_2(m,n)}{M * N} \right]^2$$

$$PSNR = \left( 10 \log_{10} \left[ \frac{R^2}{MSE} \right] \right)$$

This image metric is used to evaluate the quality of a filtered image and thereby the capability and efficiency of a filtering process.

V.EXPERIMENTAL RESULTS

i. Gaussian noise

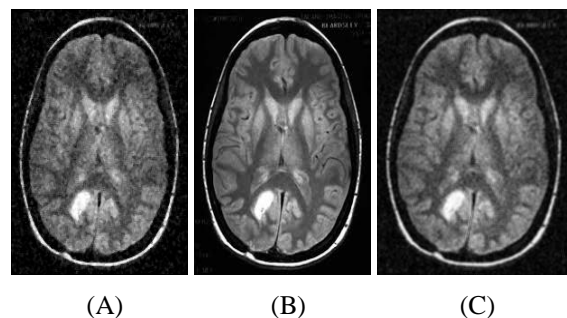

ii. Salt & pepper noise

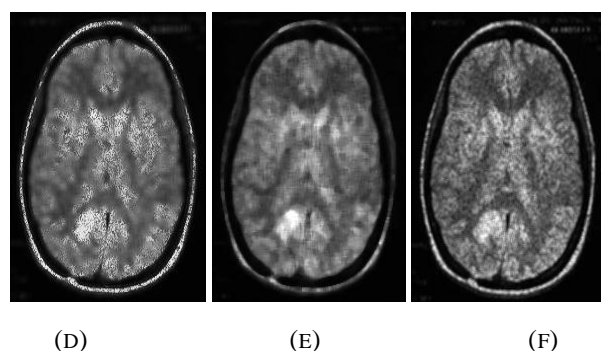

iii. Speckle noise

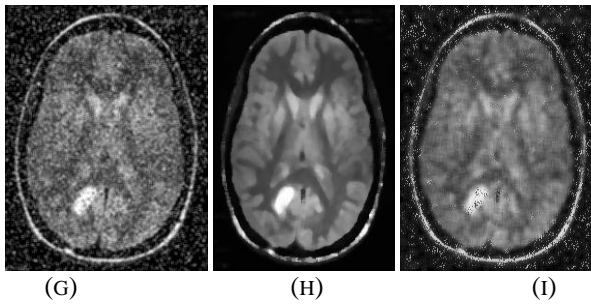

Fig 4: Denoised Images (A) Meanfiltering-Gaussian (B)Median Filtering- Gaussian (C) Weiner Filter Gaussian (D) Meanfiltering-Salt&Pepper (E) Median Filtering- Salt&Pepper (F) Weiner Filter- Salt&Pepper (D) Meanfiltering-Speckle (E)Median Filtering-Speckle (F) Weiner Filter- Speckle

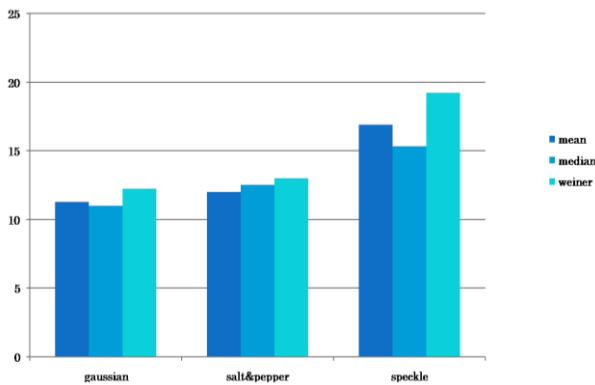

Fig5: Psnr comparison in filtering

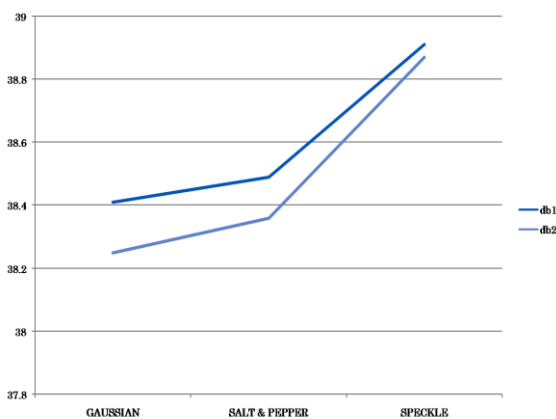

Fig 6: PSNR Comparison in Image Enhancement

VI. CONCLUSION

The MR brain image is pre-processed by de-noising and resolution enhancement to improve the quality of an image. In de-noising, the noise gets reduced better by wiener filtering rather than the mean or median filter. The PSNR got increased in wiener filter. So, thus wiener filter is good for removing the Gaussian noise rather than mean and median filter .Also median filter has better performance in reducing salt and pepper noise. The

resolution of an image is enhanced by interpolation based discrete wavelet transform that preserves the edges and contour information.

On performing quantitative analysis, the resolution enhancement technique is having better PSNR compared to the de-noised image. Thus, while analysing image pre-processing both the image de-noising and resolution enhancement techniques are inevitable for improving the qualitative performance of an image that enables accurate diagnosis

REFERENCES

- [1] Alexandra Constantin, Ruzena Bajcsy, Berkeley Sarah, "Unsupervised Segmentation of Brain Tissue in Multivariate MRI," IEEE international conference on Biomedical imaging: from nano to Macro, pp. 89-92, April 2010
- [2]. A.Sindhu, S.Meera, " A Survey on Detecting Brain Tumour in MRI Images Using Image Processing Techniques", IJIRCCE Vol. 3, Issue 1, January 2015.
- [3] Sezal Khera, Sheenam Malhotra, "Survey on Medical Image De noising Using various Filters and Wavelet Transform", International Journal of Advanced Research in Computer Science and Software Engineering, Volume 4, Issue 4, pp-230-234, April 2014
- [4] Govindaraj.V, Sengottaiyan.G, " Survey of Image Denoising using Different Filters", Volume 2, Issue 2, pp-344-351, February 2013
- [5] Bobby and Manish Mahajan, " performance comparison between filters and wavelet transform in image denoising for different noises", International Journal of Computer Science and Communication Vol. 2, No. 2, , pp. 637-639, July-December 2011.
- [6] " V. Vani, Automatic Intensity Graph Method for Brain and Tumor Segmentation Using Density Measures", The International Journal Of Science & Technoledge, Vol 2 Issue 7,pp-345-349 July, 2014
- [7]. Mona Mahmoudi, Guillermo Sapiro, "Fast Image and Video Denoising via Non-Local Means of similar neighbourhood", IEEE Signal Processing Letters , vol. 12, pp. 839-842, 2005.
- [8]. L. Sahawneh, B. Carroll, " Stochastic Image Denoising using Minimum Mean Squared Error (Wiener) Filtering," Electrical and Computer Engineering ,pp. 471 – 474, 2009.
- [9]. Jianhua Luo, Yuemin Zhu, and Isabelle E. Magnin, "Denoising by Averaging Reconstructed Images: Application to Magnetic Resonance Images", IEEE transactions on biomedical engineering, vol. 56, pp 666- 674 , March 2009.
- [10]. Ning Chun-yu, liuShu-fen, QU Ming, "Research on removing noise in medical image based on median filter method," IT in medicine and education ,Vol. 1, pp. 384 – 388, 2009.
- [11] Zeinab A. Mustafa and Banazier A. Abraham, "K11. Modified Hybrid Median Filter for Image De-noising" 29th national radio science conference (nrsc 2012)
- [12]. Gurmeet Kaur 1 and Jagroop Singh 2 "Performance Evaluation of various Image De-noising Techniques" Journal of Information and Computing Science Vol. 8, No. 1, 2013, pp. 013-026
- [13]. Toran Lal Sahu 1 "A Survey on Image Noises and Denoise Techniques" International Journal of Advanced Research in Computer Engineering & Technology (IJARCET) Volume 1, Issue 9, November 2012
- [14]. Suresh Kumar, Papendra Kumar, Manoj Gupta, Ashok Kumar Nagawat, "Performance Comparison of Median and wiener filter in image denoising", International Journal of Computer Applications , vol. 4, pp . 0975 – 8887, November 2010
- [15]. Bagawade P. Ramdas S. Bhagawat Keshav M. Patil Pradeep, "Wavelet Transform Techniques for Image Resolution Enhancement", International Journal of Emerging Technology and Advanced Engineering, Vol. 2, PP. 62 -65, April 2012
- [16] Shashikant Agrawal, Rajkumar Sahu, "Wavelet Based MRI Image Denoising Using Thresholding Techniques", International Journal of Science, Engineering and Technology Research (IJSETR) Volume 1, Issue 3, pp-32-35 September 2012.