

# Denoising ECG Signal Using Daubechies and Symlet Wavelet Transform Techniques

Tanuj Yadav<sup>1</sup>, Rajesh Mehra<sup>2</sup>

M.E. Scholar, Department of Electronics & Communication Engineering, NITTTR, Chandigarh, UT, India<sup>1</sup>

Associate Professor, Department of Electronics & Communication Engineering, NITTTR, Chandigarh, UT, India<sup>2</sup>

**Abstract:** In latest years, Electrocardiogram (ECG) acting a commanding role in heart sickness diagnostics, Human Computer Interface (HCI), stresses and emotional states valuation, etc. Generally, ECG signals exaggerated by noises such as baseline wandering, power line interference, electromagnetic intervention, and high frequency noises during data acquirement. With the purpose of recollect the ECG signal morphology; numerous researches have implemented using diverse preprocessing approaches. In this paper, wavelet filtering based Debauchees and Symlet techniques are used to improve SNR and minimize MSE of the ECG signals. The maximum SNR is obtained as 52.07374 dB and the average value of MSE in soft and hard thresholding is 0.0744559. As the SNR is improving the artifacts of ECG signals are fetched up to the optimum level and the exact diagnosis of the heart is possible.

**Key Words:** Arrhythmia, Electrocardiogram, Electrodes, SNR, Thresholding, Wavelet, FIR Filter ECG Signal, IIR Filter

## I. INTRODUCTION

Signal processing today is performed in the vast majority of systems for ECG analysis and interpretation. The objective of ECG signal processing is manifold and comprises the improvement of measurement accuracy and Reproducibility (when compared with manual measurements) and the extraction of information not readily available from the signal through visual assessment. In many situations, the ECG is recorded during ambulatory or strenuous conditions such that the signal is corrupted by different types of noise, sometimes originating from another physiological process of the body [1]. Hence, noise reduction represents another important objective of ECG signal processing; in fact, the waveforms of interest are sometimes so heavily masked by noise that their presence can only be revealed once appropriate signal processing has first been applied. Heart rate frequency is very important health status information.

The frequency measurement is used in many medical or sport applications like stress tests or life treating situation prediction [2]. One of possible ways how to get heart rate frequency is compute it from the ECG signal. Heart rate frequency can be detected from ECG signal by many methods and algorithms. The detection of low-level, alternating changes in T wave amplitude is another example of oscillatory behavior that has been established as an indicator of increased risk for sudden, life-threatening arrhythmias. Neither of these two oscillatory signal properties can be perceived by the naked eye from a standard ECG printout [3]. Common to all types of ECG analysis—whether it concerns resting ECG interpretation, stress testing, ambulatory monitoring, or intensive care monitoring—is a basic set of algorithms that condition the signal with respect to different types of noise and artifacts, detect heartbeats, extract basic ECG measurements of wave amplitudes and durations, and compress the data for efficient storage or transmission [4]. The block diagram in Fig. 1 presents this set of signal processing algorithms. Although these algorithms are frequently implemented to operate in sequential order, information on the occurrence time of a heartbeat, as produced by the QRS detector, is sometimes incorporated into the other algorithms to improve performance [5].

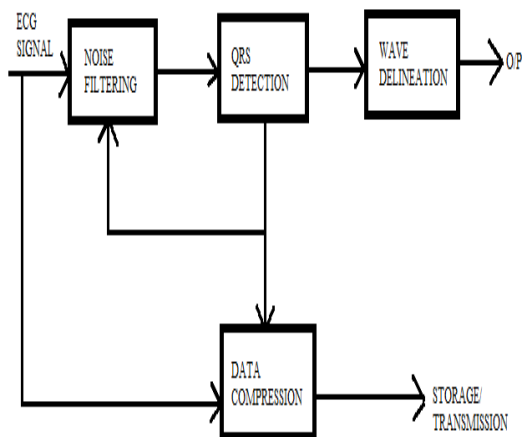

Fig.1 ECG Signal Processing Algorithm

## II. ECG SIGNAL FILTERING

Electrocardiographic signals may be recorded on a long timescale (i.e., several days) for the purpose of identifying intermittently occurring disturbances in the heart rhythm. As a result, the produced ECG recording amounts to huge data sizes that quickly fill up available storage space [6]. Transmission of signals across public telephone networks

is another application in which large amounts of data are involved. For both situations, data compression is an essential operation and, consequently, represents yet another objective of ECG signal processing. Signal processing has contributed significantly to a new understanding of the ECG and its dynamic properties expressed by changes in rhythm and beat morphology [7].

**A. ADAPTIVE FILTERING**

Adaptive filtering involves the change of filter parameters (coefficients) over time. It adapts to the change in signal characteristics in order to minimize the error. It finds its application in adaptive noise cancellation, system identification, frequency tracking and channel equalization [8]. Fig. 2 shows the general structure of an adaptive filter.

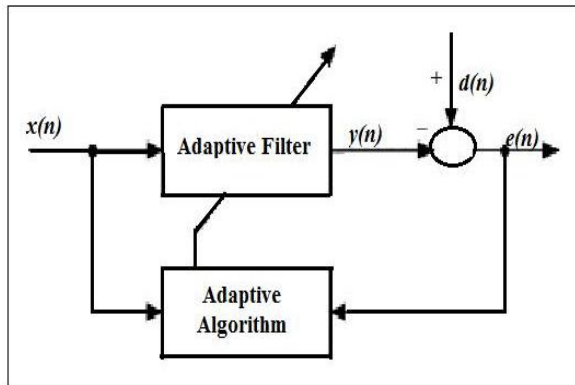

Fig.2 Adaptive filter structures

In Figure 2,  $x(n)$  denotes the input signal. The vector representation of  $x(n)$  is given where in Equation 1. This input signal is corrupted with noises. In other words, it is the sum of desired signal  $d(n)$  and noise  $v(n)$ , as mentioned in Eq.1. here, The input signal vector is  $x(n)$  which is given by

$$x(n) = [x(n), x(n-1), \dots, x(n-N+1)]^T \quad 1$$

$$x(n) = d(n) + v(n) \quad 2$$

The adaptive filter has a Finite Impulse Response (FIR) structure. For such structures, the impulse response is equal to the filter coefficients. The coefficients for a filter of order  $N$  are defined as in equation 3.

$$W(n) = [w_n(0), w_n(1), \dots, w_n(N-1)]^T \quad 3$$

The output of the adaptive filter is  $y(n)$  which is given by in equation 4.

$$y(n) = W(n)^T x(n) \quad 4$$

The error signal or cost function is the difference between the desired and the estimated signal is represented in equation 5.

$$e(n) = d(n) - y(n) \quad 5$$

Moreover, the variable filter updates the filter coefficients at every time instant is shown in equation 6.

$$W(n+1) = W(n) + \Delta W(n) \quad 6$$

Where,  $\Delta W(n)$  is a correction factor for the filter coefficients. The adaptive algorithm generates this correction factor based on the input and error signals [9].

**B. Adaptive Algorithms**

In adaptive filters, the weight vectors are updated by an adaptive algorithm to minimize the cost function. The algorithms used by us for noise reduction in ECG in this thesis are least mean square (LMS), Normalized least mean square (NLMS), sign data least mean square (SDLMS), sign error least mean square (SELMS) and sign-sign least mean square (SSLMS) algorithms.

**(a) LMS algorithm**

It is a stochastic gradient descent method in which the filter weights are only adapted based on the error at the current time. According to this LMS algorithm the updated weight is given in equation 7.

$$W(n+1) = W(n) + 2 \cdot \mu \cdot x(n) \cdot e(n) \quad 7$$

Where,  $\mu$  is the step size.

**(b) NLMS algorithm**

The NLMS algorithm is a modified form of the standard LMS algorithm. The NLMS algorithm updates the coefficients of an adaptive filter by using the following equation 8.

$$W(n+1) = W(n) + 2 \cdot \mu \cdot \frac{x(n)}{\|x(n)\|^2} \cdot e(n) \quad 8$$

Eq. 8 can be rewritten as

$$W(n+1) = W(n) + 2 \cdot \mu(n) \cdot x(n) \cdot e(n) \quad 9$$

From Eq. 7 and Eq. 9, the NLMS algorithm becomes the same as the standard LMS algorithm except that the NLMS algorithm has a time-varying step size  $\mu(n)$ . This step size improves the convergence speed of the adaptive filter.

**(c) SDLMS algorithm**

In SDLMS algorithm, the sign function is applied to the input signal vector  $x(n)$ . This algorithm updates the coefficients of an adaptive filter using the following equation 10.

$$W(n+1) = W(n) + 2 \cdot \mu \cdot \text{sgn}(x(n)) \cdot e(n) \quad 10$$

**(d) SELMS algorithm**

In SELMS, the sign function is applied to the error signal  $e(n)$ . This algorithm updates the coefficients of an adaptive filter using the following equation 11.

$$W(n+1) = W(n) + 2 \cdot \mu \cdot x(n) \cdot \text{sgn}(e(n)) \quad 11$$

(e) SSLMS algorithm

Here, the sign function is applied to both  $e(n)$  and  $x(n)$ . This algorithm updates the coefficients of an adaptive filter using the following equation 12.

$$W(n+1) = W(n) + 2 \cdot \mu \cdot \text{sgn}(x(n)) \cdot \text{sgn}(e(n)) \quad 12$$

(f) RLS algorithm

The recursive least square (RLS) algorithm is used in adaptive filters to find the filter coefficients which provides highly correlated output as that of noise signal added in original ECG signal. As shown in Figure1, The ECG signal,  $s$  is the uncontaminated signal.  $(s+c)$  is the contaminated ECG signal.  $c$  and  $d$  are the noisy signals, generated by noisy source. Our basic task here is to correlate the signal  $n$  (which is the reference signal) with that of  $c$  by identifying the parameters of adaptive filter. This  $n$  signal is mixed with the contaminated ECG signal. At the end we obtain the original ECG signal. So the filter coefficients are estimated iteratively to minimize the error between contaminated signal and original ECG signal just by finding the closest value of  $n$  as that of  $c$  [10].

**III. ECG DE-NOISING USING WAVELET TRANSFORM**

In this proposed method, the corrupted ECG signal  $x(n)$  is denoised by taking the DWT of raw and noisy ECG signal. A family of the mother wavelet is available having the energy spectrum concentrated around the low frequencies like the ECG signal as well as better resembling the QRS complex of the ECG signal. We have used symlet wavelet, which resembles the ECG wave. In discrete wavelet transform (DWT), the low and high frequency components in  $x(n)$  is analyzed by passing it through a series of low-pass and high-pass filters with different cut-off frequencies. This process results in a set of approximate coefficients ( $cA$ ) and detail coefficients ( $cD$ ). To remove the power line interference and the high frequency noise, the DWT is computed to level 4 using symlet8 mother wavelet function and scaling function. Then the approximate coefficients at level 4 ( $cA_4$ ) are set to zero. After that, inverse wavelet transform (IDWT) of the modified coefficients are taken to obtain the approximate noise of the ECG signal. The residue of the raw signal and the approximate noise is obtained to get noise free ECG signal.

A. Daubechies Wavelet Transform

Daubechies wavelet is used for decomposition of a signal in time-frequency scale plan. Daubechies wavelets, discrete wavelet transform come under a family of orthogonal wavelets and having the characteristics of maximal number of vanishing moments. Denoising using wavelets involves decomposition of a signal at level  $N$  by selecting a particular wavelet function. Then a denoised version of input signal is obtained by thresholding the detailed coefficients for each level from 1 to  $N$  using a threshold rule and applying hard or soft thresholding

methods. In hard thresholding the coefficients having absolute value lower than the threshold tent to zero. In this thresholding signal value is  $x$  if  $x > \text{thr}$ , and is 0 if  $x \leq \text{thr}$ . Soft thresholding has nice mathematical properties and it is an extension of hard thresholding, Soft thresholding makes the coefficients zero whose absolute values are lower than the threshold, and then shrinks coefficients having non-zero value towards 0. [11]. The original proposed, noisy proposed and the filtered signals using wavelet based filtering is shown in figure 4.2. In this, the original signal which contains all useful information for the purpose of diagnosis is destroyed. The results show that the noise is removed using debauchies techniques based on wavelet filtering. From the figures it can be clearly seen that the original signal is improved by reducing side lobes and increasing main lobes which contain most useful information.

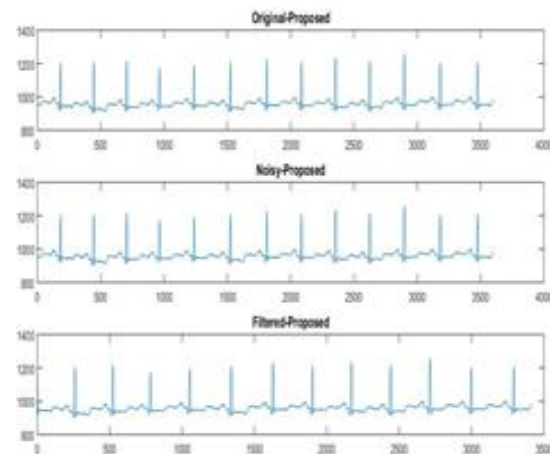

Fig.3 ECG Signal using DB-4

B. Symlet Wavelet Transform

Symlet wavelets are a family of wavelets. They are a modified version of Daubechies wavelet with increased symmetry. The properties of the two wavelet families are similar. There are 7 different Symlet functions from sym2 to sym8. In sym $N$ ,  $N$  is the order.

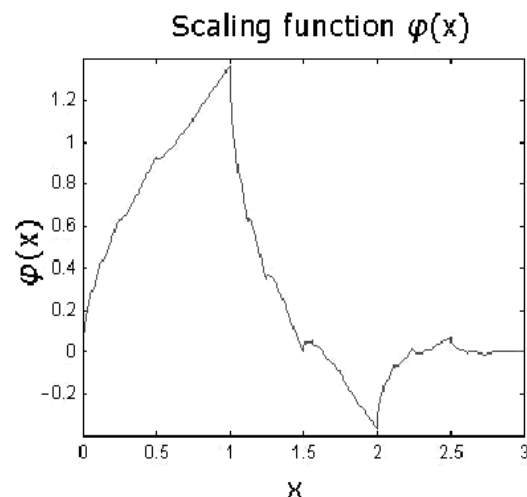

Fig.4 Symlet Function curve

C. Soft and Hard Thresholding

Further two kind of wavelet thresholding is also again implemented here. In figure 5, soft thresholding whereas in figure 6 hard thresholding is shown in terms of three figures, original, noisy and the filtered signal. In case of soft thresholding maximum SNR is obtained as 44.4948 dB and in case of hard thresholding it is 34.47528 dB. The obtained SNR for soft thresholding lies from 30 to 35 dB, for hard thresholding 40 to 45 dB and the proposed technique gives maximum SNR.

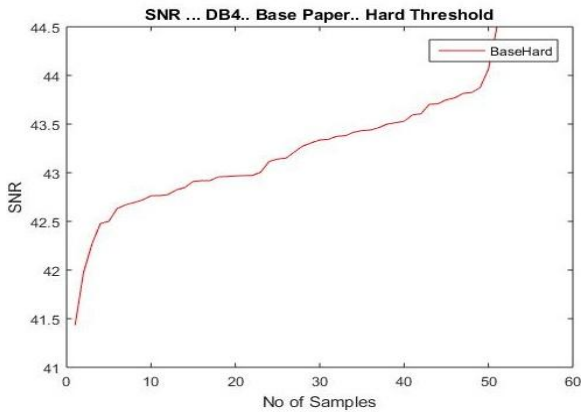

Fig.5 DB4 based SNR Soft Thresholding

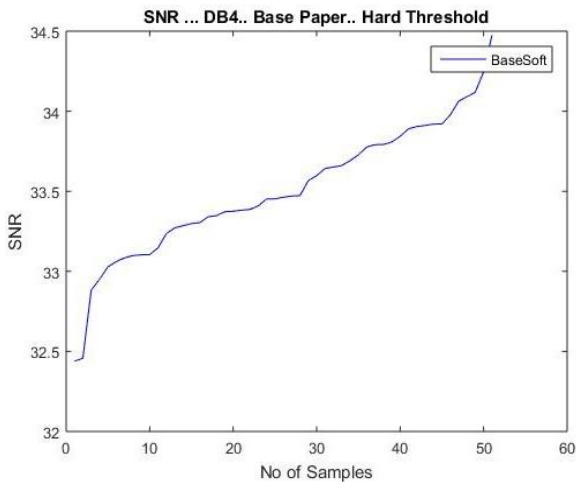

Fig.6 DB4 based SNR Hard Thresholding

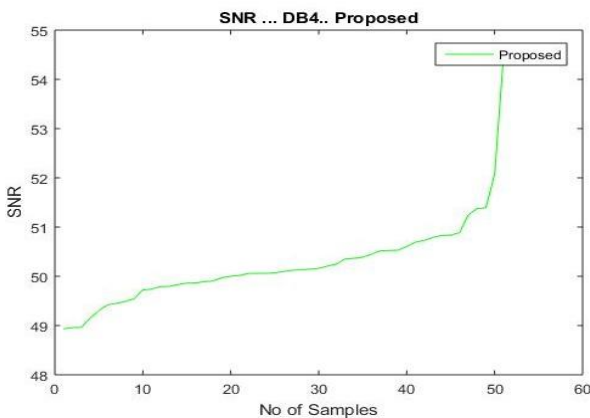

Fig.7 Proposed DB4 based SNR Thresholding

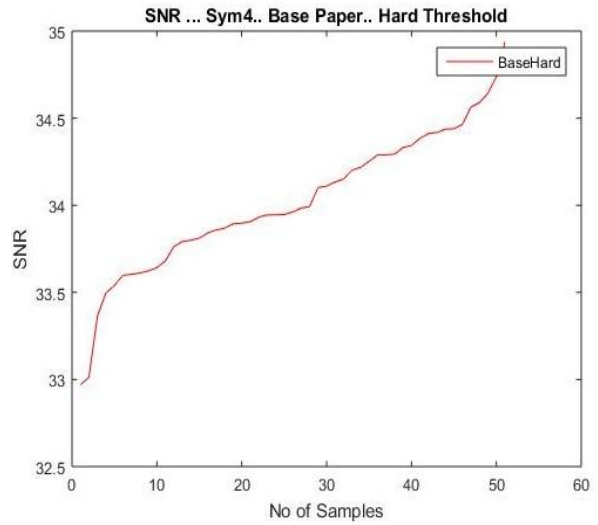

Fig.8 Sym4 based SNR Hard Thresholding

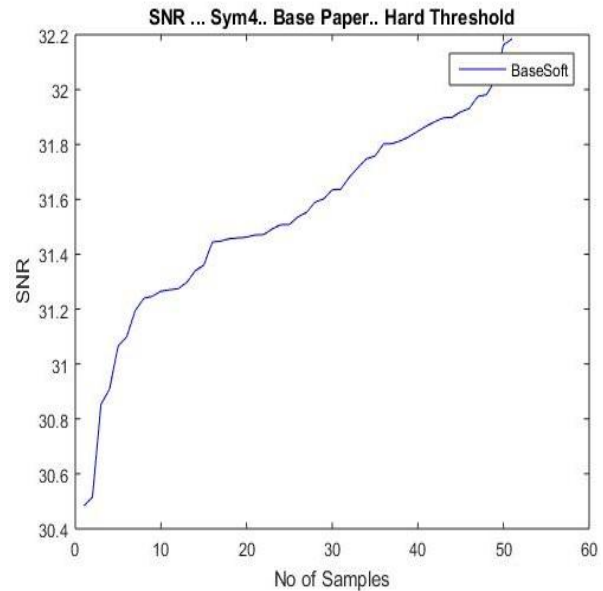

Fig.9 Sym4 based SNR Soft Thresholding

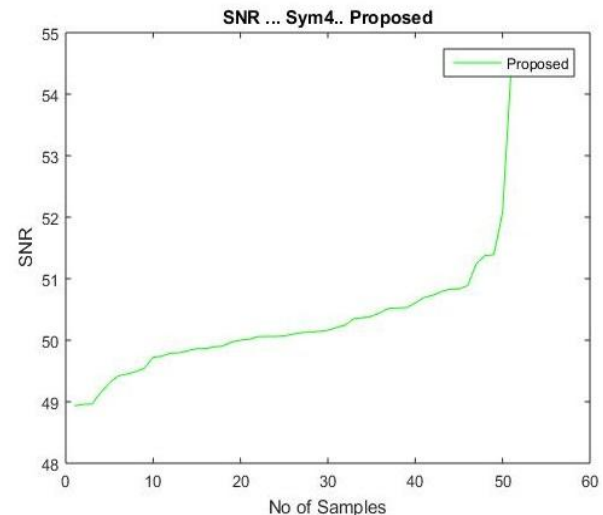

Fig.10 Proposed Sym4 based SNR Thresholding

IV. RESULT ANALYSIS

Total 27 signals are used for the denoising purpose. The signal to noise ratio is calculated using the DB-4 technique and compared with the already calculated SNR using DB-4, hard and soft thresholding. The maximum SNR is achieved as 52.07374 dB which is much improved as compare to the 43.87352 dB in case of hard and soft thresholding using DB-4. The calculated numerical values of SNR of different signals are shown in table.1. The Debauchies (DB) technique which is based on wavelet filtering is used to reduce the noise in ECG signal and to improve the SNR. The maximum SNR is obtained as 52.07374 dB. As the SNR is improving the artifacts of ECG signals are fetched up to the optimum level and the exact diagnosis of the heart is possible.

Table 1 Comparison of

| SNR      |          |           |           |          |
|----------|----------|-----------|-----------|----------|
| Hard-DB4 | Soft-DB4 | Hard-Sym4 | Soft-Sym4 | Proposed |
| 42.95898 | 33.34102 | 33.869168 | 31.634703 | 50.07099 |
| 43.76856 | 33.84314 | 34.342888 | 31.802905 | 49.42124 |
| 43.14095 | 33.45251 | 33.961928 | 31.265294 | 48.93244 |
| 43.14977 | 33.38217 | 33.893818 | 31.459659 | 50.2089  |
| 43.6051  | 33.47043 | 33.944809 | 31.247114 | 50.36615 |
| 43.51402 | 33.92077 | 34.437847 | 31.883821 | 50.82919 |

SNR (dB)

Table 2 Comparison of MSE

| MSE      |          |           |           |          |
|----------|----------|-----------|-----------|----------|
| Hard-DB4 | Soft-DB4 | Hard-Sym4 | Soft-Sym4 | Proposed |
| 0.074557 | 0.074557 | 0.074557  | 0.074557  | 0.074551 |
| 0.07456  | 0.07456  | 0.07456   | 0.07456   | 0.074559 |
| 0.074448 | 0.074448 | 0.074448  | 0.074448  | 0.074434 |
| 0.074446 | 0.074446 | 0.074446  | 0.074446  | 0.074443 |
| 0.074501 | 0.074501 | 0.074501  | 0.074501  | 0.074499 |
| 0.074605 | 0.074605 | 0.074605  | 0.074605  | 0.074616 |

The calculated numerical values of MSE of different signals are shown in table.2. The average value of MSE in soft and hard thresholding is 0.0744559. The comparative curve between the existing and the proposed filtering is shown in figure 8. The obtained SNR for soft thresholding lies from 30 to 35 dB, for hard thresholding 40 to 45 dB and the proposed technique gives maximum SNR.

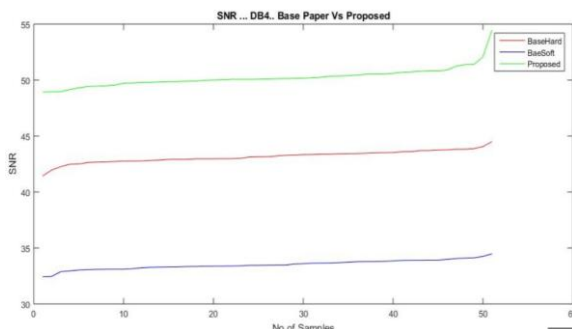

Fig.11 Comparison of Hard, Soft and Proposed DB-4 Technique

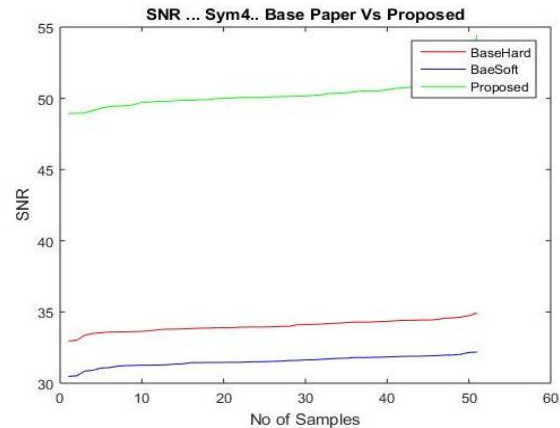

Fig.12 Comparison of Hard, Soft and Proposed symlet4 Technique

V.CONCLUSION

The filtering techniques used in this paper are wavelet filtering based Debauchees and Symlet for the purpose of ECG denoising, in which the low and high frequency components in the noisy ECG signal  $x(n)$  is analyzed by passing it through a series of low-pass and high-pass filters with different cut-off frequencies. Different kind of thresholding functions are used for this, such as Soft Thresholding and Hard thresholding.

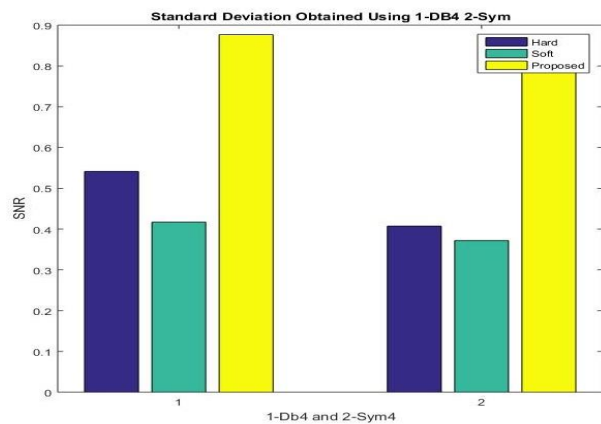

Fig 13SNR Comparison Chart

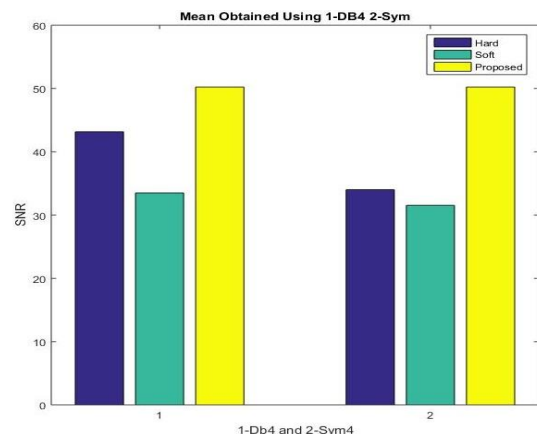

Fig.14MSE Comparison Chart



The Debauchies (DB) and Symlettechnique which is based on wavelet filtering is used to reduce the noise in ECG signal and to improve the SNR and MSE. The maximum SNR is obtained as 52.07374 dB and the average value of MSE in soft and hard thresholding is 0.0744559. As the SNR is improving the artifacts of ECG signals are fetched up to the optimum level and the exact diagnosis of the heart is possible. The residue of the raw signal and the approximate noise is obtained to get noise free ECG signal. The proposed method removes noise from the ECG signal without any distortion of the ECG signal features.

### ACKNOWLEDGEMENT

The authors would like to thank Director, National Institute of Technical Teacher's Training & Research, Chandigarh, **Mr. Rajendra Singh Yadavand** mentors for their constant inspirations and support throughout this research work.

### REFERENCES

1. P. W. Macfarlane and T. D. W. Lawrie, eds., *Comprehensive Electrocardiology. Theory and Practice in Health and Disease*, vols. 1, 2, 3. New York: Pergamon Press, 1989.
2. J. J. Bailey, A. S. Berson, A. Garson, L. G. Horan, P. W. Macfarlane, D. W. Mortara, and C. Zywiets, Recommendations for the standardization and specifications in automated electrocardiography: bandwidth and signal processing. *Circulation* 1990; 81:730-739.
3. J. A. van Alste, W. van Eck, and O. E. Herrman, ECG baseline wander reduction using linear phase filters. *Comput. Biomed. Res.* 1986; 19:417-427.
4. L. Soironmo, Time-variable digital filtering of ECG baselinewander. *Med. Biol. Eng. Comput.* 1993; 31:503-508.
5. L. Soironmo and P. Laguna, *Bioelectrical Signal Processing in Cardiac and Neurological Applications*. Amsterdam: Elsevier (Academic Press), 2005.
6. J. C. Huhta and J. G. Webster, 60-Hz interference in electrocardiography, *IEEE Trans. Biomed. Eng.* 1973; 43:91-10.
7. C. D. McManus, D. Neubert, and E. Cramer, Characterization and elimination of AC noise in the electrocardiogram: a comparison of digital filtering methods. *Comput. Biomed. Res.* 1993; 26:48-67.
8. Shilpa Saxena, Rajesh Mehra, "Performance Comparison of Adaptive FIR Filter using Different Algorithms", *International Journal on Advanced Research in Electrical and Electronic Engineering*, Vol.1, Issue.4, pp.59-64, 2014.
9. A. Bhavani Sankar, D. Kumar and K. Seethalakshmi, "Performance Study of Various Adaptive Filter Algorithms for Noise Cancellation in Respiratory Signals", *International Journal on Signal Processing*, Vol.4, No.5, pp.267-278, December 2010.
10. G. Hari Kiran, B. T. Krishna, "Noise Cancellation of ECG Signal Using Adaptive Technique", *International Journal of Research in Computer and Communication Technology*, Vol 3, Issue 4, pp.556-562, April 2014.
11. Md. Ashfanoor Kabir, Celia Shahnaz, "Denoising of ECG signals based on noise reduction algorithm in EMD and wavelet domains", *IEEE Conference*, pp 284-287, 21-24 Nov. 2011.