



# Embedded Based Vehicle Speed Control System Using Wireless Technology

Divyansh Jain<sup>1</sup>, Arun Kumar Burman<sup>2</sup>, Rajesh Parasere<sup>3</sup>

Student, Department of Electronics and Communication, Gyan Ganga College of Technology, Rajeev Gandhi

Technical University, Jabalpur, India<sup>1,2</sup>

Professor, Department of Electronics and Communication, Gyan Ganga College of Technology, Rajeev Gandhi

Technical University, Jabalpur, India<sup>3</sup>

**Abstract:** The research focus on unifying the Global Positioning system with embedded wireless system is the new approaches in intelligent vehicle control for critical remote location application using ARM. In conventional system they are designed to control the speed of vehicles in all days. The main objective of the proposed system is to operate the vehicle in safe speed at critical zones. The base station having the transmitter which is designed for Frequency Modulation (FM), the receiver part is implemented in Vehicle. The ARM processor is implemented at receiver side, which receives the critical frequency, and then it is activated in critical mode. Speed Control Driver (SCD) can be custom designed to fit into a vehicle's dashboard, and displays information on the vehicle. Once the information is received, it automatically alerts the driver, to reduce the speed according to the time and zone. The novel system is implemented with the support of embedded processor and the simulation is achieved through Kiel, C software and results are discussed.

**Keywords:** ARM Processor, GPS, Frequency Modulation, RTC, Kiel, C Software.

## I. INTRODUCTION

Nowadays road facilities are a major concern in the developed world. Recent studies show that one third of the number of fatal or serious accidents are associated with excessive or inappropriate speed, as well as changes in the roadway (like the presence of road-work or unexpected obstacles). Reduction of the number of accidents and mitigation of their consequences are a big concern for traffic authorities, the automotive industry and transport research groups. One important line of action consists in the use of advanced driver assistance systems, which are acoustic, hectic or visual signals produced by the vehicle itself to communicate to the driver the possibility of a collision.

These systems are somewhat available in commercial vehicles today, and future trends indicate that higher safety will be achieved by automatic driving controls and a growing number of sensors both on the road infrastructure and the vehicle itself. A prime example of driver assistance systems is cruise control, which has the capability of maintaining a constant user pre-set speed and its evolution, the adaptive cruise control (ACC), which adds to CC the capability of keeping a safe distance from the preceding vehicle. A drawback of these systems is that they are not independently capable of distinguishing between straight and curved parts of the road, where the speed has to be lowered to avoid accidents.

However, curve Warning systems (CWS) have been recently developed that use a combination of global positioning systems (GPS) and digital maps obtained from a Geographical Information System (GIS), to assess threat levels for a driver approaching a curve to quickly. Likewise, intelligent speed assistance (ISA) systems warn the driver When the vehicle's velocity is inappropriate, using GPS in combination with a digital road map containing information about the speed limits.

However useful, these systems are inoperative in case of unexpected road circumstances (like roadwork, road diversions, accidents, etc.), which would need the use of dynamically generated digital maps. The aim of this research is to maintain the speed control over restricted area like (schools, hospitals, colleges etc.,) by using GPS technology.

## II. MASTER WORKS

In Rubini .R, et al [1] proposed a system has an alerting, recording and reporting system for over speed violation management. The Zigbee transmitter sends the speed limit of the particular lane entered by the vehicle and also gives Alerts like "road works", "steep slopes", "school zone" in the form of acoustical messages and also in LCD.



The Receiver unit placed in the vehicle receives the messages and sends to the microcontroller. When speed of the vehicle Nears the speed limit it displays the warning and if exceeds the limit, the microcontroller records the violated speed and time. The LCD displays the lane speed limit and shows the number of times, speed was violated. A GSM module sends Message to the nearest traffic personnel immediately after a violation occurs. An authenticated device is also provided, which can be operated only by the traffic police in whom he can retrieve the data stored at any time? Increase in the count of violation increases the penalty amount which can be collected in toll gates located nearby.

In S.P. Bunker, et al [2] described a real-time online safety prototype that controls the vehicle speed under driver fatigue. The purpose of such a model is to advance a system to detect fatigue symptoms in drivers and control the speed of vehicle to avoid accidents. The main components of the system consist of number of real time sensors like gas, eye blink, alcohol, fuel, impact sensors and a software interface With GPS and Google Maps APIs for location.

In G. Sathya, et al [3] achieved with the help of “AARS using GPRS 3G TECHNOLOGY”. Through this, we can provide a smooth flow for the ambulance by controlling the traffic light according to the ambulance location to reach the hospital. The location of the ambulance can be easily identified with the help of the GPS unit installed in it. A controller in the traffic junction can automatically control the traffic flow and thus reduces the time delay taken by ambulance to the hospitals.

The traffic junction band the ambulance will have GPRS 3G modem to communicate between them. The chances of misusing the ambulance can overcome with the help of an RFID tag given to the Doctor’s in the respective hospitals so that the security can be attained. This scheme is helpful for the Traffic police to control the traffic thereby helping the patients who are facing emergency.

In S.P. Bhumkar et al [4] described a real-time online safety prototype that controls the vehicle speed under driver fatigue. The purpose of such a model is to advance a system to detect fatigue symptoms in drivers and control the speed of vehicle to avoid accidents.

The main components of the system consist of number of real time sensors like gas, eye blink, alcohol, fuel, impact sensors and a software interface With GPS and Google Maps APIs for location. In Jyotika Kapur et al [5] dealing with India there has been an increase of 17.4% in the total number of road accidents during the period of 2011-2012. This percentage has raised eyebrows and caught the attention of many to curb the growing rate. It is found that

80% of the times it is the fault of the driver. This can be avoided if we could device a mechanism which could alert the driver about the coming Jeopardy. This can be achieved by monitoring the distance between two cars using Bluetooth.

If the distance decreases than the one specified, the driver would be signalled and according to the signal, necessary actions will be taken by the mini gadget present in the car. This paper proposes that with the help of Bluetooth technology, we can keep track of the speed of the car and take appropriate actions to avoid accidents.

### III. PROPOSED HARDWARE SYSTEM

The proposed hardware system portrays that the signal can be monitoring continuously with the help of GPS, if there is normal state, speed is normal. Otherwise the signals can send to an ARM Processor to reduce the vehicle speed.

The base station (transmitter) transmits the RF signals by Frequency Modulator connected with Real Time Clock (RTC). The ARM processor is programmed in such a way when the peak hours (Critical time) is exits it transmits the critical frequency.

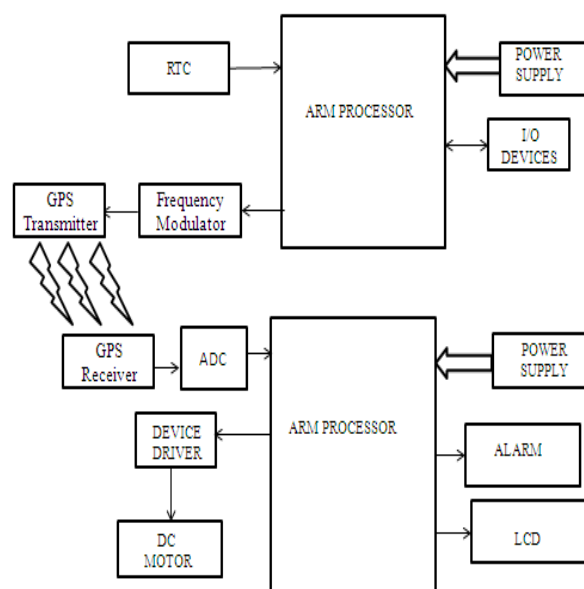

Fig.1-Block Diagram for Proposed System

In the receiver side another ARM processor is to collect the data from GPS and send the signal to device driver to operate the vehicle in safe speed. In this vehicle section. LCD Modules displays the activation of critical zone. While using frequency modulator fix at particular frequency in a transmitter side, whenever vehicle moving on a critical area automatically check and matching the frequency range.



**IV. SOFTWARE IMPLEMENTATION**

The proposed system has implemented Kiel C development tools for the ARM family to support every level of developer from the Professional applications engineer to the student just learning about embedded software development.

The industry standard Kiel C compilers, Macro assemblers, Debuggers, Real time kernels, and single board computers support all compatible derivatives and help you to get your projects completed on schedule. With the Kiel tools, we can generate embedded applications for virtually every ARM process applications. Kiel C vision 4 helps provide the variation simulation output.

**A. FLOWCHART-**

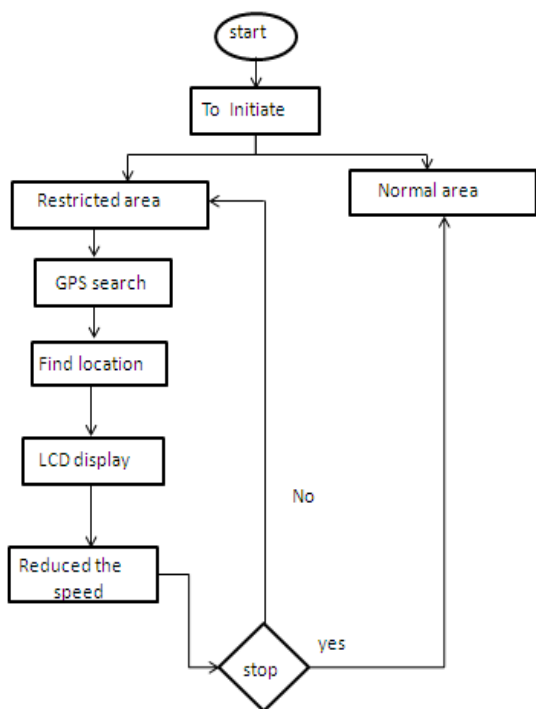

**B. ALGORITHM**

- Step1:** Start the process.
- Step2:** initialize power is supplied to vehicle section and GPS as well as GSM.
- Step3:** Two stages are vehicle section and pedestrian limit.
- Step4:** Two areas are normal speed and restricted area.
- Step5:** The GPS ready to track the location and display the message by using LCD.
- Step6:** Automatically getting reduced the speed by limit.
- Step7:** After the process completed it getting move to original state.
- Step8:** Stop the process.

**C. SIMULATION RESULT-**

In our research we use the ARM 7 processor board for [porting our ideas. Since after the debugging, we get the results in UART window].

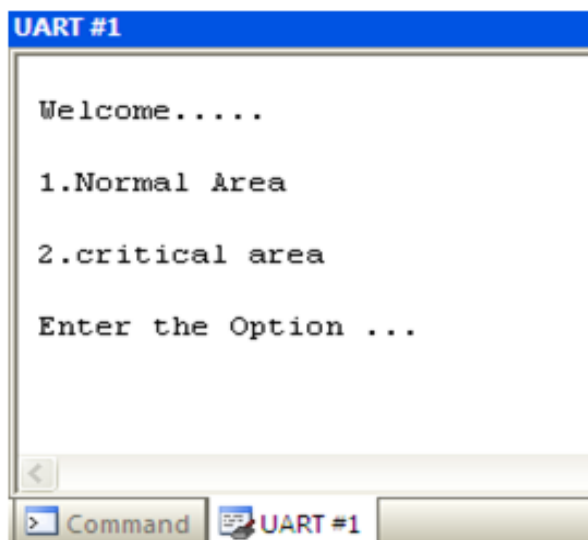

The UART show the microcontroller is displaying the modes of operation and wait for input.

Now MODE 1 is selected, UART displays to select the desired area 1 or 2(for displaying normal or critical area) then UART display when normal mode activated no indication is occur.

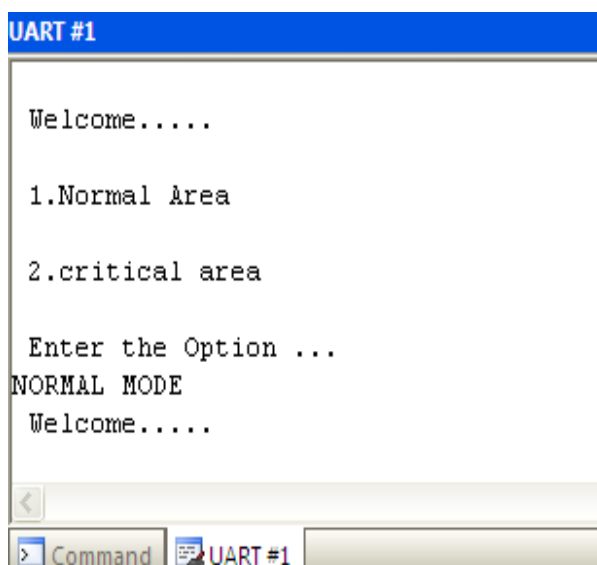

MODE 2 operations was selected, UART displays to select the desired area 1 or 2(for displaying normal or critical area) then UART display when critical mode is activated alarm become raising.



### V.CONCLUSION

The proposed system mainly designed in order to avoid accidents and to alert the drivers about the speed limits for safe traveling. An effective solution is provided to develop the intelligent vehicle which will operates on safest speed at critical zones and monitor various parameters of vehicle in-between constant time period and will send this data to the base unit is explained in this paper. Controlling the vehicle speed automatically in real time is very difficult. So, in order to avoid those difficulties, instead of controlling the vehicle speed automatically, this research paper succeeded in alerting the driver about the speed limits and detecting the critical area. The entire system is control and the advantage of small volume and high reliability. Future scope of that is to control the accidents and positioning the accidental vehicle. Many existing systems have discussed about the road safeties and have proposed many methods for the speed limitations and detection the critical area. The result is simulated and achieved by Kiel C software.

### REFERENCES

- [1] Rubini .R and Uma Makeswari .A, "Over Speed Violation Management of A Vehicle through Zigbee" Vol.5 No 1 Feb-Mar2013.
- [2] S.P. Bhumkar, V.V. Deotare, R.V. Babar "Accident avoidance and detection on highways" Vol.3 Issue2-2012.
- [3] G.Sathya, Fathima Shameema S, Jyothi Mol Sebastian, Jemnya K Automatic Rescue System for Ambulance and Authoritative Vehicles", Vol.2 - Issue 4 April - 2013.
- [4] S.P. Bhumkar, V.V. Deotare, R.V.Babar,I.Sinhgad "Intelligent Car System for Accident Prevention Using ARM-7" Volume 2, Issue 4, April 2012).
- [5] Jyotika Kapur "Accident Prevention via Bluetooth" Volume 2, Issue4, July 2013.
- [6] Ashish Shrivastava, Member, IEEE, Shivam Bhardwaj, Nitin Pachauri, Rajat Kumar Singh, Sachin Kumar and Sandeep Kumar Jaiswal. "Vehicle Speed Violation Detection Using RF Communication". Vol. 1, Issue 8, October 2012.
- [7] Rajesh Kannan Megalingam, Vineeth Mohan, Paul Leons, Rizwin Shooja, Ajay M, "Smart Traffic Controller using Wireless Sensor Network for Dynamic Traffic Routing and Over Speed Detection", IEEE Global Humanitarian Technology Conference (GHTC),pp:528 - 533, 2011.
- [8] Turgay Celik and Huseyin Kusetogullari, "Solar-Powered Automated Road Surveillance System for Speed Violation Detection", IEEE Transactions on Industrial Electronics, pp: 3216 - 3227, 2010.