

“Automatic Driving Robot Simulation in MATLAB with Hardware”

Prof. Vivek Mahawadiwar¹, Shivani Dongre², Onkar Wanjari³, Nidhi Tangselwar⁴, Sourabh Tipramwar⁵

Electronics Department, K.D.K.C.E, Nagpur¹⁻⁵

Abstract: Obstacle avoidance is one of the most important phase of mobile robotics. Without it, robot movement would be very confining and breakable. This project proposes robotic vehicle that has an intelligence built in it such that it directs itself whenever an obstacle comes in its path. So to protect the robot from any physical harm. This can be design to build an obstacle avoidance robotic vehicle using ultrasonic sensors for its motion. A micro-controller (AT mega 328P) is used to achieve the desired operation. An ultrasonic sensor is used to determine any obstacle ahead of it and sends a command to the micro-controller. Depending on the input signal received, the micro-controller redirects the robot to move in an alternate direction by actuating the motors which are interfaced to it through a motor driver.

Keywords: ArduinoUno, Arduino software, Motor Driver (L293D), Motors, ultrasonic sensor.

I. INTRODUCTION

The final goal of designing and building intelligent agent that perceive reason about, and act upon, our everyday world is shared by Artificial Intelligence (AI) and robotics. We shall discuss further advances that are essential for eventual success in this area. Vision may be done much more efficiently and+ as possible on the basis of sensory inputs, avoiding the fully when the system knows what it is looking for computational and explanatory difficulties of large databases the essence of a computer vision subfield called model based vision. The agent has such a system, allowing it to remember more about the continuing interaction with the world; it can utilize prior text of its action while retaining much of its computational knowledge to conclude what it will see.

As regards locomotion, control systems are developed for widely different styles of movement, including robots on wheels or with one or more legs, as well robots that swim and fly. Robotics is a stream of AI, which is composed of Electrical Engineering and Computer Science for designing, construction, and application of robots. Robotics are nowhere near acquiring this level of artificial Intelligence but they have made a lot of progress with more limited AI. AI machines can replicate some specific AI machines can replicate some specific elements of in intellectual ability. There is infinite variety in the size, shape and jobs of robots. Few robots are used day after day in factories, while others are highly experimental and use artificial intelligence to behave more and more like living creatures, able to act independently in changing environments.

An Intelligent Agent (IA) is an autonomous entity which observes through sensors and acts upon an environment using actuators (i.e. it is an agent) and directs its activity towards achieving goals. Intelligent agents may also learn or use Knowledge to achieve their goals. They may be very simple or very complex. Intelligent agents are often described schematically as an abstract functional system similar to a computer program. A rational agent is one that does the right thing. Obviously this is better than doing the wrong thing, but what does it mean? As a first approximation, we will say that the right action is the one that will cause the agent to be most successful.

II. LITERATURE REVIEW

This paper states that in the modern era, the vehicles are concentrate to be automated to give human driver relaxed driving. In the field of automobile various phase have been considered which makes a vehicle automated. Google, the biggest network has started working on the self-driving cars since 2010 and still cultivate new changes to give a whole new level to the automated vehicles. In this paper we have focused on two applications of automated car, one in which two vehicles have same terminal and one knows the route, where other don't. The following vehicle will chase the target (i.e. Front) vehicle automatically. The other application is automated driving during the heavy traffic jam, hence relaxing driver from repeatedly pushing brake, accelerator or clutch. The idea described in this paper has been taken from the Google car, defining the one phase here under consideration is making the terminal dynamic. This can be complete by a vehicle automatically following the destination of another vehicle.

III. EXPERIMENTAL SET UP

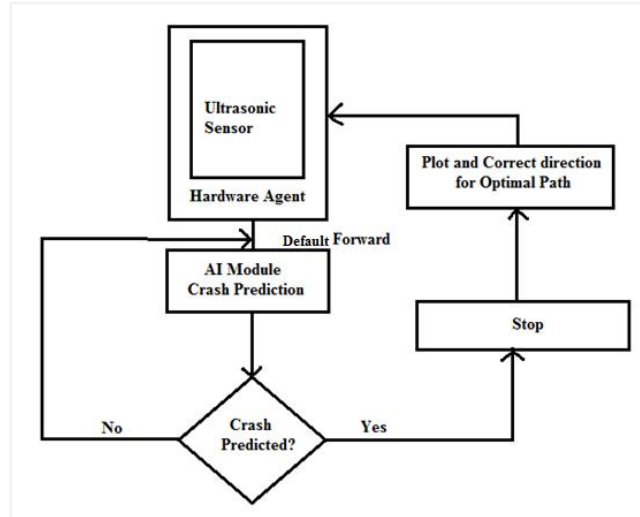

Fig1. Block Diagram

The objective of the agent is to avoid blooming without using hard-coded predefined values for stopping distance from the nearest obstacle. This is achieved by learning from initial crashes and tuning the synaptic weights to change in subsequent iterations the stopping distance. Initially individually learning is performed by the system where the robot on crashing into an obstacle, backtracks to the previous safe state, increments the current Threshold value (initially set to zero) by the learning rate and dumps the new state of the system. Optimal path calculation is then done by taking a sweep of the environment using Ultrasonic sensor mounted on a servo motor. The readings are plotted in the form of a bell shaped curve, to find the longest bitonic subsequence from the array of readings. This longest bitonic array will shows the most encouraging direction or path for the robot's movement. The hardware agent or robot is initially given a default forward. When it collides with an obstacle on its path the threshold values are tuned. The agent backtracks to the safe state once the collision has observed. The distance sensing at intervals with initial threshold as zero and a random weight of 0.5. Lower the learning rate, the more accurate forecast of collision, but with more number of iterations. excellent path calculation module performs the longest bitonic processing of the distance measures obtained from the ultrasonic sensor to detect the most promising path for the robot to move. The distance array readings for one sweep of the ultrasonic sensor on crashing, the threshold is increased by the learning rate for the next iteration of distance sensing and collision prediction. The threshold is tuned in this way each time a collision is detected. Once the threshold is tuned to the appropriate value, then crash is concluded and an optimal path where the robot can move default forward without collision is decided.

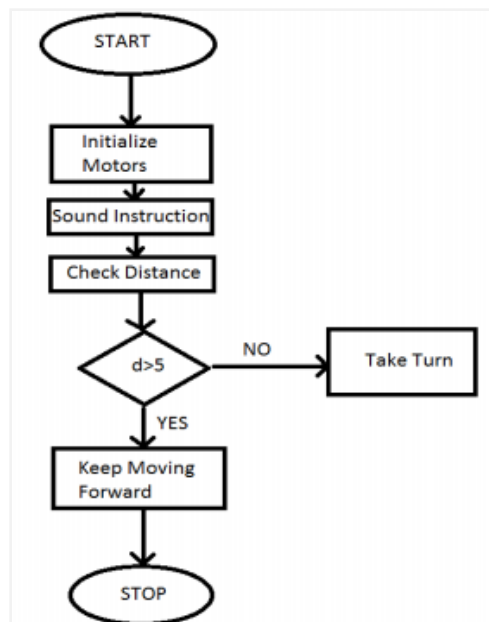

Fig2 Flowchart

This project is to build a proof-of-concept model for an autonomy framework for robots using artificial intelligence. Reinforcement learning methods will be applied by making use of models incorporating artificial neural networks. Conventionally, obstacle avoidance has been implemented using a procedural approach that makes use of predefined hard coded values; that are arrived at by means of trial and error. To cancel the need for inaccurate and hard-to-determine fixed threshold values, we use Artificial Intelligence. Initially, there will be zero knowledge present, and individually learning will be performed. The robot will be set to default to forward action until it collides with an obstacle while maintaining a buffer of all sensor readings at all times. It then reads from the buffer every time a collision is made to learn the conditions at which collisions occur. excellent path to avoid obstacle collision can be extrapolated by calculating the local maximum of the longest bitonic sub sequence in the array of distance readings taken in a length of the servo with the ultrasonic sensor mounted on top.

Sensor Technology:

A sensor is a device, module, or subsystem whose purpose is to observe events or changes in its environment and send the information to other electronics, frequently a computer processor. A sensor is always used with other electronics, whether as easy as a light or as multiple as a computer. Sensors are used in everyday objects such as touch-conscious elevator buttons (tactile sensor) and lamps which dim or brighten by touching the base, besides innumerable applications of which most people are never aware. With advances in micro machinery and easy-to-use microcontroller staging, the uses of sensors have expanded beyond the traditional fields of temperature, pressure or flow measurement, for example into MARG sensors. Moreover, analog sensors such as potentiometers and force-sensing resistors are still broadly used. Applications include manufacturing and machinery, airplanes and aerospace, cars, medicine, robotics and many other phase of our day-to-day life.

Ultrasonic Sensor:

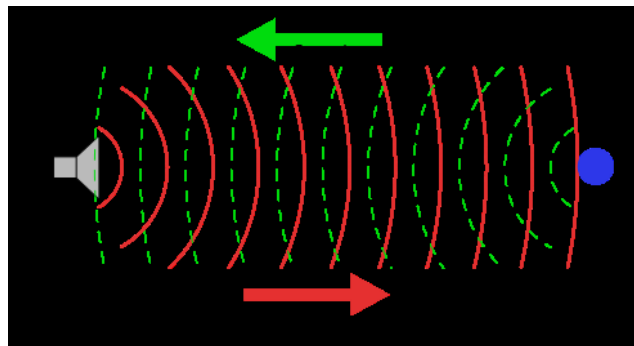

Figure3. Basic principle of Ultrasonic Sensor

As the name indicates, ultrasonic sensors calculate distance by using ultrasonic waves. The sensor head emits an ultrasonic wave and gets the wave reflected back from the target. Ultrasonic Sensors measure the distance to the target by calculating the time between the emission and reception.

An optical sensor has a transmitter and receiver, whereas an ultrasonic sensor uses a single ultrasonic element for both discharge and receiving. In a reflective model ultrasonic sensor, a single oscillator transmits and receives ultrasonic waves alternately. This enables miniaturization of the sensor head.



Fig4. Ultrasonic Sensor

Arduino Uno:



Fig5. Arduino Uno

The Arduino Uno R3 is a microcontroller board based on a detachable, dual-inline-package (DIP) ATmega328 AVR microcontroller. It has 20 digital input/output pins. Programs can be loaded on to it from the simple-to-use Arduino computer program. The Arduino has an expanded support community, which makes it a very easy way to get started working with embedded electronics. The R3 is the third, and new, revision of the Arduino Uno. The Arduino Uno is a microcontroller based on the ATmega328. It has 20 digital input/output pins a 16 MHz resonator, a USB contact, a power jack, an in-circuit system programming (ICSP) header, and a reset button. It contains everything needed to support the microcontroller; simply connect it to a computer with a USB cable or power it with an AC-to-DC adapter or battery to get started. The Uno differs from all action boards in that it does not use the FTDI USB-to-serial driver chip. Instead, it speciality an ATmega16U2 programmed as a USB-to-serial converter.

Servo Motor:

A servomotor is a rotary actuator or linear actuator that allows precise control of angular or linear position, velocity and acceleration. It include of a suitable motor coupled to a sensor for position feedback. It also need a relatively sophisticated controller, often a dedicated module designed specifically for use with servomotors. Servomotors are not a proper class of motor although the term servomotor is often used to refer to a motor suitable for use in a closed-loop control system

Stepper Motor:

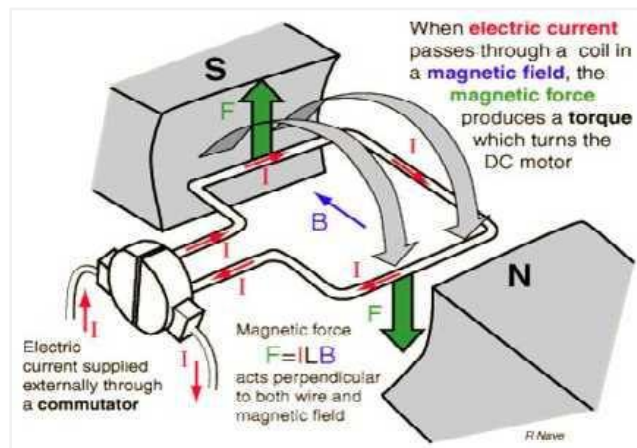

Fig6.Working of DC motor

Stepper motors are DC motors that move in distinct steps. They have multiple coils that are established in groups called "phases". By energizing each phase in sequence, the motor will move one step at a time. With a computer controlled stepping you can achieve very correct positioning and/or speed control. For this reason, stepper motors are the motor of

choice for many precision movement control applications. Stepper motors come in many distinct sizes and styles and electrical characteristics. This directs details what you need to know to pick the right motor for the job

Motor Driver (L293D):

L293D is a typical Motor driver or Motor Driver IC which allows DC motor to drive on either direction. L293D is a 16-pin IC which can control a set of two DC motors simultaneously in any direction. It means that you can control two DC motor with a single L293D IC. Dual H-bridge Motor Driver integrated circuit (IC).

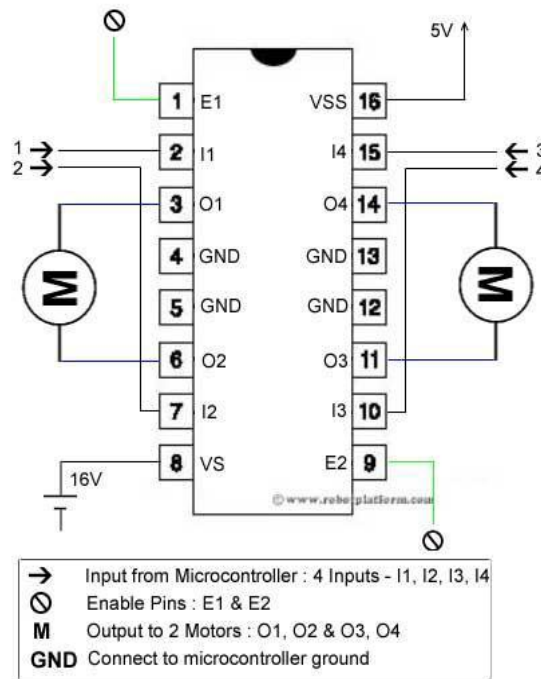

Fig7.Motor driver (L293D)

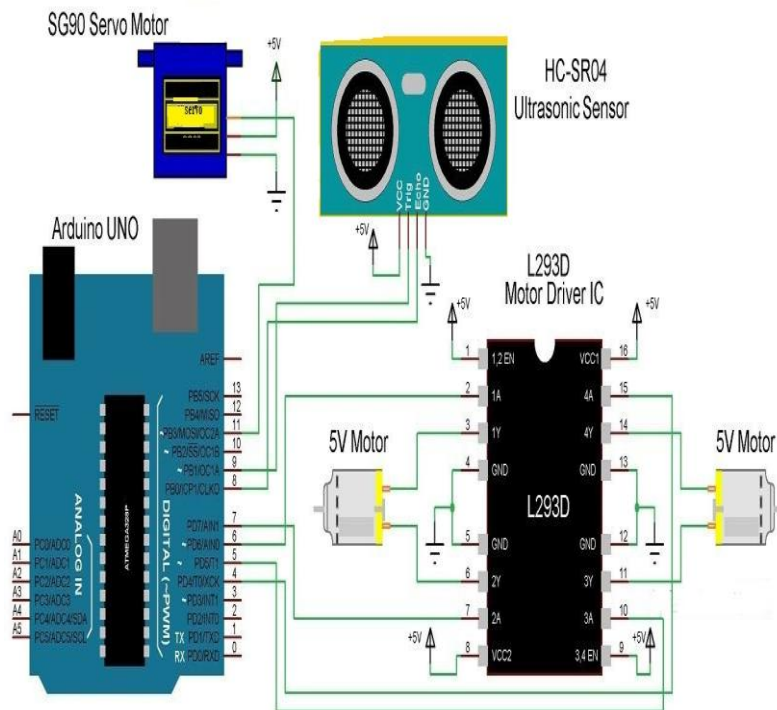

Fig8. Circuit diagram

IV. EXPERIMENTAL RESULT

This is achieved by using the various reinforcement learning methods to train the robot and make it understand the environment. Thus, this system gives a platform for any hardware framework to be implemented to avoid collision.

V. CONCLUSION

Ultrasonic technology is successfully tested, and implement for avoiding obstruction. The driver IC automatically decides the path to be followed, as given instruction by Arduino. The live streaming has no lags; Ultrasonic data and Visual data are totally matched. Bluetooth manual control is also supported with live streaming.

REFERENCES

- [1]. Saji Jacob George, Jobby C. Johnson, G. Senthilkumaran, B. Purna Chandra Rao and S. Venugopal "Obstacle Avoidance and Orientation Determination For A Remote Operated Vehicle", 2016, IEEE.
- [2]. Shahzeb Ali Department of Electronic Engineering, Mehran University of Engineering & Technology, Jamshoro, 2016, IEEE.
- [3]. Xiao-ye Wang , Ru-jing Zheng , UgurSimsir,Ying-yuan Xiao "An Intelligent Collision Avoidance Algorithm Research", 2016, IEEE.
- [4]. Stuart J. Russell and Peter Norvig, Prentice Hall, "Artificial intelligent model approach" Englewood Cliffs, New Jersey 07632.Issue 6, June 2016.
- [5]. Nischay Gupta1, Jaspreet Singh Makkar , Piyush Pandey "Obstacle Detection and Collision Avoidance Using Ultrasonic Sensors For RC Multimotors", 2015 IEEE.
- [6]. Avneet Pannu, "Artificial intelligence and its application in different areas" M.Tech Student Department of Computer Science and Engineering. International Journal of Engineering and Innovative Technology (IJETT) Volume 4, Issue 10, April 2015.
- [7]. Hamed Rezaee, Student Member, IEEE, and Farzaneh Abdollahi, Member, IEEE "A Decentralized Cooperative Control Scheme with Obstacle Avoidance for a Team of Mobile Robots", 2014 IEEE.
- [8]. Broggi, A. et al., "Extensive Tests of Autonomous Driving Technologies". 2013, IEEE.
- [9]. Andrea Cherubini and Francois Chaumette "Visual Navigation With Obstacle Avoidance", 2011, IEEE.
- [10]. Teck Chew Ng, Javier Ibañez-Guzmán, Jim Shen, Han Wang, Chen Cheng "Vehicle Following with Obstacle Avoidance Capabilities in Natural Environments", 2004, IEEE.
- [11]. Meng Guanglei, Pan Haibing "The Application Of Ultrasonic Sensor In The Obstacle Avoidance Of Quad-rotor UAV", 2004, IEEE.