

Design And implementation of Smart Energy Meter Using Internet of Things (IoT)

Neeru Batra¹, Mayuri Chawla²

M. Tech, Elect & Telecom Engineering, Jhulelal Institute of Technology, Nagpur, India¹

Professor, Elect & Telecom Engineering, Jhulelal Institute of Technology, Nagpur, India²

Abstract: The based Smart and many functions Energy Meter for Automatic Meter Reading using ATmega kit. It has provision of connecting with Central database maintained by energy provider using computing as well as Tampering detection of energy meters. which can prevent theft detection from unregistered users saving losses due to it. Remarkable feature of this meter is Internet of Things based implementation According to the market requirements of ATmega Meter there is use for smart. ATmega Meter. Nowadays the system will use Wireless system for communication protocol. The Wireless is used since the application need high speed data rate, need to be less powered with low cost. In this paper presenting the remote wireless ATmega Meter Reading System. This is to resolving the shortcomings of the technology of the traditional ATmega Meter Reading, by combining the characteristics of the Wireless technology and with Microcontroller ATmega16. The hardware implementation was designed, and then analyzed the use cases for ATmega Meter. There are more chances of manual error, delay in processing, tampering of the meter and mis usage of the Electricity by other sources. It requires so many workers, one set of workers to note down the reading and other set to cut the power if the payment is not paid at the right time.

Keywords: AT-Megha, Microcontroller, Energy Meters. Internet of things, wireless.

I. INTRODUCTION

In the Internet of Things, many of the living and non-living things that encompass us will be on the internet in one form or another. Driven by the popularity of gadgets empowered by wire-less technological innovation such as Wireless Bluetooth, Radio Frequency Identification, Wireless-Fidelity, embedded sensor, has moved out from its beginning stage and it is actually on the edge of changing the present fixed inter-net into a well featured upcoming Internet. Currently there are almost nine billion inter-connected gadgets and it is estimated to touch almost fifty billion gadgets by 2020. Today the world is facing such an environment that offers challenges. Energy crisis is the main problem faced by our society. A relevant system to control and monitor the power usage is one of the solutions for this problem. One approach through which today's energy crisis can be addressed is through the reduction of power usage in households. The consumers are increasing rapidly and also burden on electricity offering divisions is sharply increasing. The consumers must be facilitated by giving them an ideal solution Embedded systems and Real Time Operating Systems (RTOS) are two among the several technologies that will play a major role in making these concepts possible [2]. A large number of people are already depending on operating systems for real time applications, these 'eyes in the sky' are now going to make an impact on our everyday s in a more significant manner. Embedded systems are pre-designed without connections and operate as per the required task. But in operating systems instruction is design-oriented. These systems are basically platform-less systems. Embedded systems are the unsung heroes of much of the technology we use today the video game we play, or the CD player or the washing machines we use employ them. Without an embedded system we would not even be able to go online using modem Almost every car that rolls off the production line these days makes use of embedded technology in one form or the other; most of the embedded systems in automobiles are rugged in nature, as most of these systems are made up of a single chip. No driver clashes or 'systems busy' conditions happen in these systems. Their compact profiles enable them to fit easily under the cramped hood of a car. These systems can be used to implement features ranging from adjustment of the suspension to suit road conditions and the octane content in the fuel to Antilock Braking Systems (ABS) and security systems. Embedded systems are designed to do some specific task, rather than be a general-purpose computer for multiple tasks. Some also have real time performance constraints that must be met, for reasons such as safety and usability; others may have low or no performance requirements, allowing the system hardware to be simplified to reduce costs.

II. LITERATURE SURVEY

Utilities are rapidly replacing existing electromechanical meters, which are read manually once a month, with smart meters that transmit a building's electricity usage every few minutes. In 2011, an estimated 493 utilities in the U.S. had collectively installed more than 37 million smart meters. Unfortunately, smart meters also indirectly leak private, and potentially valuable, information about a building's occupants' activities. To extract this information, third-party companies are now employing cloud-based, "big data" platforms to analyze smart meter data en masse. While the purpose is, ostensibly, to provide consumers energy-efficiency recommendations, companies are mining the data for any profitable insights. For example, detecting power signatures—sequences of changes in power unique to a device—for specific appliance brands could aid manufacturers in guiding their marketing campaigns, e.g., identifying homes with General Electric versus Maytag appliances. Many utilities are providing third-party companies access to troves of smart meter data. For instance, a recent report highlights one utility's practice of requiring its customers to consent to sharing their data with third parties before permitting them to use an online web portal [9]. Such privacy violations have led to a small, but growing, backlash against smart meter deployments. Every management system is trying to make automatic, portable and remote control. This work presents a novel smart energy meter for an automatic and superior metering and billing system. The integration of the ATmega and GSM Short Message Service (SMS) provide the meter reading system with some automatic functions that are predefined. Firstly, we have simulated the project in PROTEUS 8.0 then successfully implemented on the circuit board in laboratory. The proposed energy meter system can incorporate with embedded controller and GSM modem to transmit the data like consumed energy in kWh, generated bill, security services (line Cut/On) over GSM mobile network such as data can be then fed and integrated into existing energy management systems located at power companies or organizations to provide the services among the customers without man-power. Our implemented project is able to provide all required services remotely for metering and billing with high fidelity ZigBee is a new global standard for wireless communications with the characteristics of low-cost, low power consumption, and low data rate. It has a good market in wireless meter reading. The design and implementation of a ZigBee-based wireless automatic meter reading system are proposed in this paper. The experimental results show that the design can meet the basic needs of automatic meter reading with flexibility and expansibility. It can act as a platform of wireless monitor system and supplies a new hardware design approach for wireless ZigBee networks. With the rapid development of automation and measuring techniques, automatic recording of the data in the meter reading instrument has gradually become the target of people whose working, living, and home conditions are of increasingly high level of intelligence. Meanwhile, utilities also hope that the development of new technologies to solve the problems they encountered in the practical work about cumbersome meter reading and no reliable protection of accuracy and real time; and enable both user friendly and improving public sector efficiency and management level. Existing wire-line meter reading system has a large number of risks. Wires are more complex, detrimental to adjustment and maintenance of the system. The long-term indoor and outdoor installation easily leads to aging, resulting in a risk of short circuit and breakage. For these reasons, it has become the industry very unresolved problem to design a remote meter reading system, with long-term reliance and convenient installation. & maintenance, which not only read data automatically but also monitor operation status. With the development of wireless communication technology, in recent years there comes requirement for low cost equipment of wireless networking technology, called ZigBee. It is a short range, low-complexity, low cost, low power consumption, low data rate two-way wireless communication technology with high network capacity, short time delay, safety and reliance. Its main application areas include industrial controls, consumer electronics, car automation, agricultural automation, and medical equipment control. The core of this technology is established by IEEE 802.15.4 Working Group, and the ZigBee Alliance founded in 2002 is responsible for high-level applications, interoperability testing, and marketing. Till now, the ZigBee Alliance has reached over 150 members of famous companies in the world including IBM, Ember, Mitsubishi, Motorola, and Philips, etc. Many semiconductor companies are targeting the ZigBee market. Since the standards were launched not long ago, chips in line with protocol have been available of multi-chip solution and single-chip solution. It can be expected that ZigBee will have comprehensive applications in the field of automation. The main methods of metering at home and abroad are: manual meter reading, IC Card prepaid meter, wire-line and wireless meter reading system. Manual meter reading has been for decades, but with the implementation of one home one meter, drawbacks of this method of reading are more and more, like difficult entrance to home, low efficiency of fee settlement, etc.

Designing and implementing commercial as well as industrial systems based on Wireless communication has always been a prominent field of interest among many researchers and developers. This paper presents an implementation methodology for a Wireless Automatic Meter Reading System (WAMRS) incorporating the widely used GSM network. In many countries GSM network is widely known for its vast coverage area, cost effectiveness and also for its competitive ever-growing market. Using GSM as the medium for WAMRS provides a cost-effective, wireless, always-connected, two-way data link between utility company and WAMRS, the WAMRS sends information of utility usage, power quality and outage alarm to utility company, tampering detection to the utility servers. In this paper we suggest a method where



we utilize telecommunication systems for automated transmission of data to facilitate bill generation at the server end and also to the customer via SMS, Email.

The wide proliferation of wireless communication proposes and explore new possibilities for the next generation Automatic Meter Reading whose goal is to help collect the meter measurement automatically and possibly send commands to the meters. Automation ranges from connecting to a meter through an interface for transmitting the meter measurements all the way from the meter to the utility company via GSM network. With the development of country's economy and the improvement of national power, the power requirement is still ever increasing due to use of improper power management systems and the conventional energy metering system. Over the past years, metering devices have gone through much improvement, and are expected to become even more sophisticated, offering more and more services. Meters in the past, and today in a few countries, were electromechanical devices with poor accuracy and lack of configurability. Theft detection was also a challenge. Such meters are limited to providing the amount of energy consumption on site. Recent developments in this direction seem to provide opportunities in implementing energy efficient metering technologies that are more precise and accurate, error free, etc. The implementation of WAMRS provides with many vital features as compared with the analog utility meter reading with man power. Some of these features are listed below,

1. Higher speed.
2. Improved load profile.
3. Automatic billing invoice.
4. Real time energy cost.
5. Load management.
6. Alarm warning.
7. Remote power switches on/off.
8. Tamper detection.
9. Bundling with water and gas.

WAMRS provides a two way communication between the Energy company and the load by sending in a lot of power parameters and control signal to reach the goal of load management and power demand control. Using WAMRS on distribution automation can supply many capabilities such as efficient meter-reading, distribution, power monitoring and control, load management and time-of-use rate. With rapid growth of mobile communication network, future application service will gradually concentrate on data transmission service

The internet of thing allows object to be sensed and controlled remotely across existing network infrastructure, creating opportunities for more direct integration between the physical world and computer based systems, and resulting in improved efficiency, accuracy and economic benefit. The increasing generation needs empowered gadgets by wireless technology which includes Bluetooth, Radio Frequency Identification, Embedded sensors and many more. In that technology has grown from its beginning and now presently widely using it. The electricity plays an important role in our life. Now days as the consumers are increasing rapidly it became very hard to handle the electricity requirements. Without electricity it's impossible to survive and also it is important to save the electricity loss. As the generation is increases the consumer's requirements also increasing so in accordance with it the technology improvement is needed. So we developed the system with faster and improved technology i.e. . The electricity also contains some issues like power theft. Power theft is a measure crime and it also directly affects the economy of our country. Transmission, generation and distribution of electricity include the loss of electricity. To avoid the losses we need to monitor the power consumption and losses, so that we can efficiently utilize the generated power. Meter tempering is part of power theft and also illegal crime which we can minimize. Billing is a process in general the human operator goes to every consumer's home then providing bill it will take lot of time. To resolve these issues we developed system on the base of energy meter reading. based energy meter reading consists of three parts: Controller, Theft detection and WIFI part. Controller part plays a major role in the system. Where all the information can send through this controller to the other part of the system and it also stores the information in it. WIFI part performs operation in accordance with the ATmega controller. The energy meter connected with theft detection part if any temper happens it will send the information to the company as well as it will take automatic action by making power off. The Buyer needs to pay for the usage of electricity on schedule, in case that he couldn't pay, the electricity transmission can be turned off autonomously from the distant server. The user can monitor the energy consumption in units from a webpage by providing device IP address. Theft detection unit connected to energy meter will notify company side when meter tampering occurs in energy meter and it will send theft detect information through modem and theft detected will be displayed on the terminal window of the company side. Wi-Fi unit performs the operation by sending energy meter data to web page which can be accessed through IP address. The Hardware interface circuit consists of PIC18F46k22 Microcontroller, MAX232, LCD display, theft detection unit, Triac switch circuit, DB18B20 temperature sensor, PIR sensor, PLC modem, and ESP8266 Wi-Fi module. Wi-Fi unit performs the operation by sending energy meter data to web page which can be accessed through IP address.



III. MOTIVATION

Stands for metering Meter Reading. A device which remotely obtain meter readings and transmits this data to the system's computer via communication media such as (RF communication module) or dedicated cables for processing. devices can detect outages, remotely connect and disconnect services, detects tampering as well as other uses. has benefits include increased cash flow, lower labor and equipment cost, increased accuracy and lower costs. Some customer satisfaction benefits include improved service quality, more customer choices and faster response time. If Home occupancy is monitored by tech savvy persons, then it will be detrimental from consumer side. So, this problem motivates us to avoid this problem with our proposed system. It very difficult for energy provider company to maintain records of their consumers terms of hourly consumptions of electricity. So, it motivates us to build single Centralized database that can maintain records of their consumers electrical energy consumption hourly basis and on the analysis of that home occupancy detection can be avoided, It has become trend to integrate automatic systems via wireless applications over network which motivates us to do further advancement in this regard. Along with advancement of technology of development, research on wireless applications and remote control has become popular today. An electricity meter, electric meter or energy meter is a device that measures the amount of electric energy consumed by residence, business, or electrically powered device. So, by making it tampering proof, large amount of unwanted losses to MSEB as well as nation can be controlled. Theft detection of Electrical Energy can also be monitored through our proposed system. There is huge loss occurs to Energy provider company because of unwanted theft of electrical energy which motive us to do something in this regard. With the help of centralized database, we can monitor energy consumption of user, Technological advantages in IT infrastructure services make automated billing and paying of bills easier.

IV. RESEARCH ANALYSIS

With the increasing population, residential, commercial, and industrial area, the consumption of electricity or utilization of power increases much rapid than the user numbers due to technologies and power dependent equipment and systems. It has now become imperative for utility companies to devise better, non-intrusive, environmentally-safe techniques of gauging utilities' consumption so that the correct bills can be generated and invoices. The benefit goes beyond the power consumption. It will also be the basis for power generation and more accurate demand forecasts which will lead to more efficient usage power distribution, power generation and minimizing raw material waste.

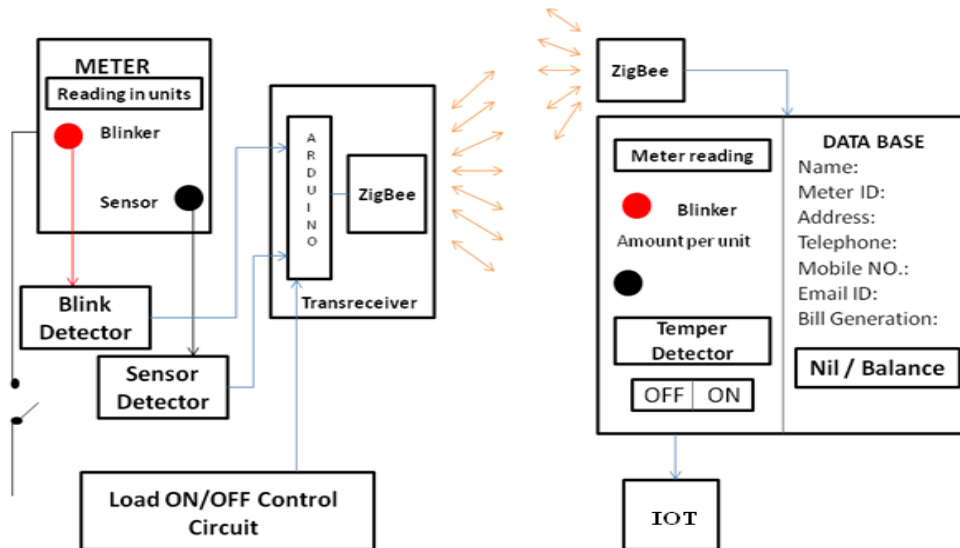

Figure 3.1 Block diagram of Wireless Meter

The smart metering system is designed to make the prevailing electricity billing system simpler and efficient. The conventional metering system is done manually. A worker of the Electricity Board will be coming to take the reading and enter in the card. There are more chances of manual error, delay in processing, tampering of the meter and misuse of the Electricity by other sources. It requires so many workers, one set of workers to note down the reading and other set to cut the power if the payment is not paid at the right time and we have very poor servicing. Manual reading can create errors in calculation. Sometimes it happens that images taken by meter reader are not in proper manner, which leads to improper calculation of bills. This problem can be avoided with our proposed project. If bill amount is not paid by the user within specified time duration, it takes time by MSEB employee to go to that particular house and disconnect the meter until bill is not paid by the consumer. This is time-consuming task, which can be overcome by our proposed system.

We are going to achieve following objectives which are further divided into two sections.

Electrical Company Benefits:-

- To implement smart automated processes instead of manual work.
- To provide Accurate information from the network load to optimize maintenance and investments.
- To provide customized rates and billing dates.
- To streamline bill investigations.
- To detect tampering of Meters.
- To provide accurate measurement of transmission losses.
- To implement better network performance and cost efficiency.
- To provide effective demand and distribution management.
- To provide more intelligence to business planning.
- To establish better company credibility.
- To prevent theft detection from unregistered users.
- To avoid tech savvy criminals to detect occupancy of consumer's home.
- To become easier of monitoring of electrical consumption of users with the help of cloud computing.

Customer Benefits:

- To provide precise consumption information.
- To provide clear and accurate billing.
- To provide metering outage information and faster recovery.
- To prevent theft due to occupancy detection of users home.

V. CONCLUSION

This paper is mainly concentrated on network. First point is we converting energy meter which is about the project there are electromagnetic into a digital meter. We are doing automatic reading and also connection and disconnection of meters using wireless module. Then meter reading has come faster. It is available for the customers. The peoples will be using the information as per their requirements and they will be having freedom to check the bill, tampering, when the meter has been connected and disconnected before the due date. So concluding that we are successfully monitored the tampering seal tampering and we have read the meter bills which also be uploaded on the website using concept. Overall, the new things we are worked with in our project are controller coupled with ATmega controller and the model. Meter Reading is a unique solution for problems in existing manual system. metering Meter Reading is self-assured automation system. Implementation of metering Meter Reading with the help of standalone system is an innovative idea. There are more chances of manual error, delay in processing, tampering of the meter and misuse of the Electricity by other sources but with the help of metering Meter Reading, we can easily overcome this. Standalone system is most suitable to implement transfer of unit. The prepaid services, we can make proper use or storage of electricity. benefits include increased cash flow, lower labor and equipment cost, increased accuracy and less costs some customer benefits include improved service quality, more customer choices and faster response time.

REFERENCES

- [1]. Dong Chen, Student Member, IEEE, Sandeep Kalra, Student Member, IEEE, David Irwin, Member, IEEE Prashant Shenoy, "Preventing Occupancy Detection From Smart Meters" IEEE Transactions on Smart Grid 2015.
- [2]. Jingrui Xie, Tao Hong, and Joshua Stroud "Long-Term Retail Energy Forecasting With Consideration of Residential Customer Attrition" IEEE Transactions on Smart Grid 2015.
- [3]. Pooja D Talwar, Prof.S.B Kulkarni " Based Energy Meter Reading" International Journal of Recent Trends in Engineering & Research (IJRTER) Volume 02, Issue 06; June - 2016 [ISSN: 2455-1457].
- [4]. Darshan Iyer N, Dr. K A Radhakrishna Rao " Based Electricity Energy Meter Reading, Theft Detection and Disconnection using PLC modem and Power optimization" DOI: 10.15662/ijareeie.2015.0407113.
- [5]. Md.Masdur Rahman, Noor-E-Jannat,Mohd. Obidl Islam, Md.Serzas Salak in "ATmega And Gsm Based Smart Energy Meter For Advanced Metering And Billing System" IEEE 2015 Ref 8-1-463-666-2/15 & 2nd Int'l Conf. on Electrical Engineering and Information and Communication Technology (ICEEICT) 2015.
- [6]. Maninderpal Singh, Er.Varun Sanduja "Minimizing Electricity Theft by Internet of Things" International Journal of Advanced Research in Computer and Communication Engineering Vol. 4, Issue 8, August 2015.
- [7]. Tanmoy Maity, Partha Sarathi Das, "Intelligent Online Measurement and Management of Energy Meter Data Through Advanced Wireless Network" Ref 978-1-4244-9190-2/11 ©2011 IEEE.
- [8]. Lei Haijun ,Li Lingmin, Li Xianyi3 "A Novel Preprocessing Approach for Digital Meter Reading Based on Computer Vision" ISBN 978-952-5726-10-7 Proceedings of the Third International Symposium on Computer Science and Computational Technology(ISCST '10) Jiaozuo, P. R. China, 14-15, August 2010, pp. 308-311.
- [9]. Deepa Warudkar, Priyamvada Chandel, B.A.Sawale "Anti -Tamper Features In Electronic Energy Meters" International Journal of Electrical, Electronics and Data Communication, ISSN: 2320-2084 Volume-2, Issue-5, May-2014
- [10]. M. Anas, N. Javid, A. Mahmood, S.M.Raza, U.Qasim, Z.A.Khan "Minimising Electricity theft using Smart Meters in AMI " Seventh International Conference on on P2P, Parallel, Grid, Cloud and internet computing,2012