



# Literature Review on IOT based Society Water Management with Automatic Bill Generation

**Prof. Deepali Shinkar<sup>1</sup>, Kajal Thakur<sup>2</sup>, Ajay Dongare<sup>3</sup>, Jitendra Pawar<sup>4</sup>, Nilofar Pathan<sup>5</sup>**

Assistant professor, Department of Information Technology, JSPM's BSIOTR, Pune, India<sup>1</sup>

Student, Department of Information Technology, JSPM's BSIOTR, Pune, India<sup>2-5</sup>

**Abstract:** Water is generally regarded as precise and tonic of life. Water shortage has become an important heartbreak. Water shortage is defined as the lack of sufficient available water in all the water resources particularly to meet the demands of water usage. For this core factor we need to save water in all the aspects possible. When we are going to buy a home in residential apartment/society. Therefore, society must have important amenities like automatic water maintenance bill to detect usage of water by individual flats. The objective of IOT based Society Water Management with Automatic Bill Generation system is to provide smart monitoring of water flow in pipes and purity of drinking water, to minimize the wastage of the water and to distribute the water bill according to the usage of water per flat. A comparative study of pros and cons of these approaches have been perceived and the performance metrics of purity, leakage in water pipes and time of responses have been discussed in this survey paper. Also description of IOT based Society Water Management with Automatic Bill Generation using ESP8266 controller.

**Keywords:** Water wastage, IoT, Water Quality, Water Management, ESP8266.

## I. INTRODUCTION

Water is an important resource for all the life on the earth. Water comes in one of the five basic needs to survive for every living thing on Earth. Water is generally regarded as precise and limit resource. Although more amount of water is available on earth but only limited amount of fresh water is available for human activities. System management requires human intervention. Water management is now a major problem in housing. This issue affects various processes such as water management, water consumption, distribution, and maintenance of system detection and equipment. Sometimes the water tank is filling and water is overflow. If we can control this we can save large amounts of water. Conventional water tanks can neither monitor nor control the water level in the tank. As of now, the water level has to be manually checked and refilled according to the requirements. The main aim of the system is to minimize the wastage of the water and to distribute the water bill according to the usage of water per flat. So in this paper, we solve all the above mention problems with automatic water level detection and refilling of water storage system with the help of Internet of Things (IoT). We are going to implement IOT based Society Water Management with Automatic Bill Generation System the Water Level and Flow is Measured by Sensors and the Data is Transmitted and Collected Through Wi-Fi module.

## II. LITERATURE SURVEY

In this paper Smart Water Management system using Microcontroller ZR16S08 as IoT Solution presents that system operates through the smart monitoring of the water flow in pipes of the water distribution network, aiming to ensure the quality of the water supply, knowing that water losses characterize one of the great problems in the world, as pipe holes may be open doors to water contaminants. [1]

In the Water Management system, IoT, automation is one of the essential attributes. This increases comfort and convenience in the lives of people. We would like to provide this in the domain of water management. Our motive is to help the readers understand the importance of using water judiciously and equipping them with the knowledge of the functioning of water management system which is done by using Internet of Things (IoT). [2]

OPC UA (Object Linking and Embedding for Process Control Unified Architecture) is a platform independent service-oriented architecture for the control of processes in the logistics and manufacturing sectors. Based on this standard we propose a smart water management model combining Internet of Things technologies with business processes coordination and decision support systems. They provide an architecture for sub-system interaction and a detailed description of the physical scenario in which we will test our implementation, allowing specific vendor equipment to be manageable and interoperable in the specific context of water management processes. [3]

Water is always a crucial part of everyday life. Due to global environmental situation, water management and conservation is vital for human survival. In recent times, there were huge needs of consumer based humanitarian projects

that could be rapidly developed using Internet of Things (IoT) technology. In this paper, we propose an IoT based water monitoring system that measures water level in real-time. Our prototype is based on the idea that the level of the water can be very important parameter when it comes to the flood occurrences especially in disaster prone areas. A water level sensor is used to detect the desired parameter, and if the water level reaches the parameter, the signal will be fed in real-time to social networks like Twitter. A cloud server was configured as data repository. The measurement of the water levels is displayed in remote dashboard. [4]

In this paper, aim of IoT-Enabled Adaptive Smart Water Distribution Management System is to facilitate water distribution management as well as analyze the demand and consumption behavior for the citizens. Advantages of this system, the nature of hierarchical design facilitates the detection of faulty components as it exploits the idea of decomposition of the system into subsystems. It based on a dynamic knowledge- based system that is used to analyze the demand and the consumption as well as to detect any leakage occurrence. But downside of this system, it will be costly a needs a multidisciplinary team with different specialties. Therefore, this work will mainly focus on design as a first step to be presented to a support fund organization. Suggest that Using AI algorithms that can control the water distribution based on the parameters collected from our system. This increases the opportunity to make our system scalable and applicable to the enterprise level and increase the level of maintainability. [5]

In this system, IoT based Smart Water Quality Monitoring System(SWQM) goal of this research is to develop SWQM system using the IoT platform. Four physical parameters: temperature, pH, conductivity and turbidity of different water samples are measured via four sperate sensors equipped with Arduino Uno. The extracted sensor data are analyzed using the fast forest binary classifier. A desktop application is developed in .NET platform to identify whether the tested water samples are safe or unsafe for human consumption. this system can be implemented for real time water monitoring solution in near future. [6]

In this system IoT and Cloud Computing based Smart Water Metering System focuses on the developmental and implementation methodology of smart water meter based on Internet of Things (IoT) and Cloud computing equipped with machine learning algorithms. Our smart water meter has low infrastructural cost, as only Node MCU and the water flow sensor was used in recording, visualizing and analyzing the water flow patterns. Then transmitted at regular intervals to the Thing Speak Cloud platform once internet connectivity. Machine learning model linear regression and linear support vector machine model which is used to analyzing flow patterns, analysis specific to each water pipe trained specifically

for every water meter, and generation of alerts. The system rewarded that reliability and accountability of visualization and analysis of the data is also very high. It is very low cost system. But for a large scale implementation, it would encumber a cost.[7]

### III. PROPOSED SYSTEM

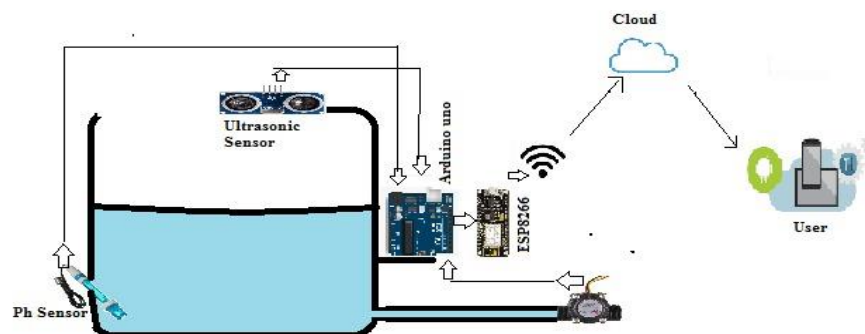

In the Society Water Management with Automatic Bill Generation system, we proposed IoT based automation instead of manual water management. An electronic system is designed to control and monitor the level of water in a tank. The electronic system is designed to automatically control and display water levels. In our project the system achieves proper water management and enhances productivity from automation. Our idea is to detect the usage of water by individual flats and bill them accordingly using IOT based Flow sensor sensors. Also the owner will be kept updated in real time about their water usage via

- Arduino Uno: - Arduino is an open-source electronics platform based on easy-to-use hardware and software. Arduino boards are able to read inputs – light on a sensor, a finger on a button, or a Twitter message and turn it into an output- activating a motor turning on an LED, publishing something online.
- ESP8266: - ESP8266EX offers a complete and self-contained WiFi networking solution. It is also used to host the application or to offload WiFi networking functions from another application processor. It is among the most integrated WiFi chip in the industry.



- Ph sensor: - pH scale is used to measure the acidity and basicity of a liquid. It can have readings ranging from 1-14 where 1 shows the most acidic liquid and 14 shows the most basic liquid. 7 pH is for neutral substances that are neither acidic nor basic
- Ultrasonic sensor: - **Ultrasonic sensors work** by emitting sound waves at a frequency too high for humans to hear. They then wait for the sound to be reflected back, calculating distance based on the time required. This is similar to how radar measures the time it takes a radio wave to return after hitting an object
- Flow sensor: - By using a flow sensor microcontroller like Arduino, we can calculate the flow rate, and check the volume of liquid that has passed through a pipe, and control it as required.

#### IV. CONCLUSION

According to the United Nation's World Water Development Report, by 2050 more than 50% of the world's population will be under high water scarcity. To avoid water stress, water resources are needed to be managed more securely. Using sensor technology, provides online monitoring which helps in managing water resources more efficiently. IoT based automated water distribution and performance monitoring system focuses on various entities such as proper supply, over consumption alert and water quality assurance. IoT domain combines with cloud computing and Machine learning algorithm, analyze water quality, water flow pattern and make alert system to avoid wastage of water. Our literature review paper has summarized the work carried out by various researchers related to smart water management, associated problems, and their solutions, in the last two decades. Our proposed IOT based Society Water Management with Automatic Bill Generation system aim is to identify the problems and find out real time solutions to make effective smart water system and user has to pay effective cost of water as per their usage.

#### REFERENCES

- [1] Michel R. Machado, Tiago Ribas Júnior, Michele R. Silva, João B. Martins; "Smart Water Management System using Microcontroller ZR16S08 as IoT Solution", 2019 IEEE 10th Latin American Symposium on Circuits & Systems (LASCAS), IEEE 18 March 2019
- [2] Kaushik Gupta, Mandar Kulkarni, Manas Magdum, Yash Baldawa, Prof. Shivprasad Patil; "Smart Water Management in Housing Societies using IoT"; 2nd International Conference on Inventive Communication and Computational Technologies, April 2018
- [3] Chanda Rajurkar, S R S Prabaharan, S. Muthulakshmi, "IoT based water management", IEEE 2017 International Conference on Nextgen Electronic Technologies: Silicon to Software (ICNETS2), 16 October 2017
- [4] Thinagaran Perumal, Md Nasir Sulaiman, Leong.C.Y; "Internet of Things (IoT) Enabled Water Monitoring System", 2015 IEEE 4th Global Conference on Consumer Electronics (GCCE), 04 February 2016
- [5] Muhannad Al-Jabi Haya Sammaneh IoT-Enabled Adaptive Smart Water Distribution Management System 2019 International Conference on Promising Electronic Technologies (ICPET)
- [6] Monira Mukta, Samia Islam, Surajit Das Barman, Ahmed Wasif Reza, M Saddam Hossain Khan IoT based Smart Water Quality Monitoring System 2019 IEEE 4th International Conference on Computer and Communication Systems
- [7] 2020 International Conference on Power Electronics & IoT Applications in Renewable Energy and its Control (PARC) GLA University, Mathura, UP, India. Feb 28-29, 2020 IoT and Cloud Computing based Smart Water Metering System