



Design & implementation of IOT based Remote Health Monitoring System

Mrs.Sukeshini P.Balwir¹, Mrs Pradnya R.Morey¹, Ms.Kavita R.Katole², Mrs.P.N.Nagrale³

^{1*}Assistant professor, Department of Electronics Engineering,

^{2*} Assistant professor, Department of Electronics & Communication Engineering,
Dr.Babasaheb Ambedkar College of Engineering and Research, Nagpur, India

^{3*}Scientist, ARDE, DRDO, Pune

Abstract: Health care sensors are playing a vital role in hospitality. Patient monitoring system, a major improvement in hospitality because of its advanced technology. In the present busy days constant monitoring of the patient's body parameters such as temperature and heartbeat rate etc. becomes difficult. Hence to remove the burden of monitoring patient's health from doctor's head, we present the methodology for monitoring patients remotely using embedded technology which can provide medical feedback to the patients through mobile devices based on the installed sensors. The deployed embedded technology provides easy and continuous monitoring of patient and is available at a reasonable price.

Keyword : Mobile Health monitoring ,IOT, Aurdino ,sensor

I. INTRODUCTION

In today's busy life, mobile computing devices make information easily accessible for everyone from anywhere at any time. Advancement in the mobile devices could be beneficial for healthcare workers to provide accurate and reliable realtime information. Continuous patient monitoring in terms of their body temperature and heartbeat rate is very important and becomes difficult.

The available technology which is routinely used for patient monitoring has different sections for collection, processing the data and due to which the information is not available in a real time. On the other hand, the sensors often connected with unwieldy wires and connected to the monitoring devices which provides discomfort to the patients due to their physical intervention. The available devices which are currently used for continuous patient monitoring are quite heavy and expensive and are fixed in nature. Therefore, there is a need of a process which could be cost effective, flexible, easy to use and portable in nature.

The proposed work describes designing of simple, cost-effective system based on embedded technology for remotely monitoring of patients which would help for effective communication between doctor and patient and in turn doctor to take an appropriate action at proper time.

Few studies have been already reported in which advanced mobile technology has been used for different purposes. One such example includes use of solar energy for traction purpose in which solar energy gets converted into electrical energy by employing solar panel. Another example includes designing railway track gap detection autonomous vehicle using Microcontroller, IR obstacle Sensors assembly system, which detects the gap along its path. The central component of the whole system is a microcontroller.

II. SYSTEM REPRESENTATION

There are mainly two parts of the system one is transmitter and the other one is the receiver. In the transmitter, we have Heartbeat sensor, and the temperature sensor. All the sensors are connected to the patient. The microcontroller monitors the all the system in the transmitter if any abnormality in the patient condition then it sends the signal so that the receiver will capture the signal and will work according to that. Block diagram for patient monitoring system is given in Figure 1 and final circuit diagram of intelligent mobile based patient monitoring is given in Figure 2.

The block diagram explains the IoT Based Patient Health Monitoring System using Arduino. EEG Sensor and LM35 Temperature Sensors & heart beat sensor respectively. The sensors are connected to microcontroller Aurdino UNO through amplifiers. The amplifiers processes the sensors signals and give the input to aurdino. Aurdino processes the input signal through coding and displays result to 16*2 LCD Display. ESP8266 Wi-

Fi module connects to Wi-Fi and sends the data to IoT device server. The IoT server used here is Thingspeak. Finally, the data can be monitored from any part of the world by logging into the Thingspeak channel.

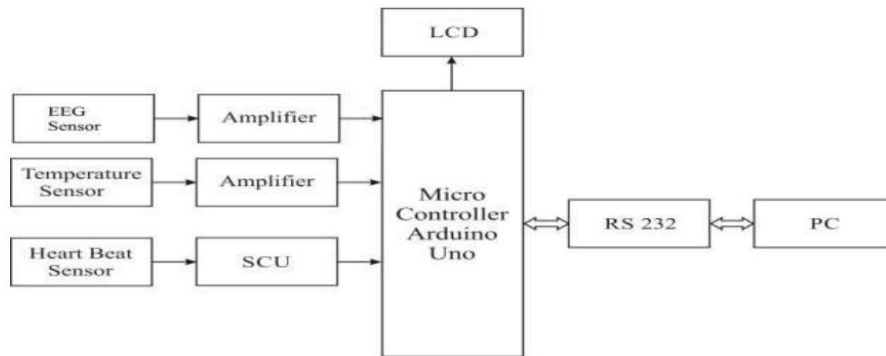

Figure 1. Block diagram for patient monitoring system.

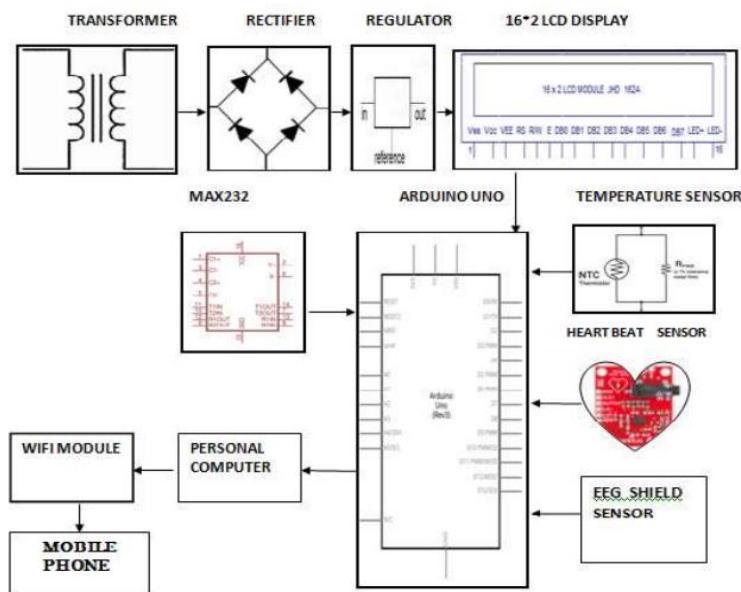

Figure 2. Circuit Diagram

III. HARDWARE USED:

The sensors, hardware and software used in this project are summarised as follows.

- NODE MCU PROGRAMER 8266
- 16*2 LCD DISPLAY
- DS1820 (TEMPERATURE SENSOR)
- HEART BEAT SENSORS
- ECG SENSORS
- IC 7805 REGULATOR
- 12V ADAPTER
- CAPACITOR
- RECTIFIER
- TRANSFORMER



- RESISTOR
- POWER SUPPLY 12V
- ARDUINO SOFTWARE

III. SOFTWARE USED:

The complete system can be monitored through mobile application Blynk .

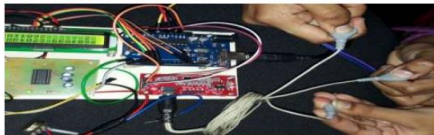

Figure 3. Output displayed in mobile application

III . Results

Following Figure shows health parameters such as temperature, ECG heart beat and ECG measurement sensor.

EEG measurement sensor



Testing	Normal value	Observed value	Status
Person 1	100-300	131	Active
Person 2	100-300	165	Active

Temperature Sensor



Testing	Normal value	Observed value	Error rate
Person 1	24	28	+4
Person 2	24	30	+6

ECG heart beat sensor



Testing	Normal value	Observed value	Error rate
Person 1	74-78	72	-2
Person 2	74-78	84	+6

IV.APPLICATIONS

The designed patient monitoring system has following applications:

- It can be operated remotely by interfacing a GSM modem system.
- It can be used in ICU's, operation theatres, monitoring of oxygen levels etc.
- It can be also used in old age homes to monitor the various parameters of a sick person in old age homes.



V.FUTURE SCOPE

Multiple patient monitoring parameters such as parameters like blood pressure, body temperature, and heart rate can be included as controlling parameters in the future. This system also developed by using mobile app using Arduino software. Also this system continuously monitor patient's condition through mobile app.

REFERENCES

- [1] S. I. Ahamed, M. M. Haque, K. Stamm, and A. J. Khan. Wellness assistant: "A virtual wellness assistant using pervasive computing". ACM Symposium on Applied Computing (SAC), Seoul, Korea, pages 782-787, March 2007.
- [2] D. M. Fraser. Biosensors: Making sense of them. Medical Device Technology, S. K. S. Gupta, S. Lalwani, Y. Prakash, E. Elsharawy, and L. Schwiebert. "Towards a propagation model for wireless biomedical applications". IEEE International Conference on Communications (ICC), 3:1993-1997, May 2003.
- [3] S. P. J. Higson, S. M. Reddy, and P. M. Vadgama. "Enzyme and other biosensors: Evolution of a technology". Engineering Science and Education Journal, pages 41-48, Feb 1994.
- [4] D. Konstantas, A. van Halteren, R. Bults, K. Wac, I. Widya, N. Dokovsky, G. Koprnikov, V. Jones, and R. Herzog. "Mobile patient monitoring: the mobihealth system". Stud Health Technol Inform, 103:307- 314, 2004.
- [5] Korhonen, R. Lappalainen, T. Tuomisto, T. Koobi, V. Pentikainen, M. Tuomisto, and V. Turjanmaa. Terva: "wellness monitoring system". Engineering in Medicine and Biology Society, 20th Annual International Conference of the IEEE, 4(29):1988-1991, Oct 1998.
- [6] Milenkovic, C. Otto, and E. Jovanov. "Wireless sensor networks for personal health monitoring: Issues and an implementation. Computer Communications", (Special issue: Wireless Sensor Networks: Performance, Reliability, Security, and Beyond), Elsevier, 29(13-14):2521-2533, Oct 2006.
- [7] J. Parkka, M. van Gils, T. Tuomisto, R. Lappalainen, and I. Korhonen. "Wireless wellness monitor for personal weight management". Information Technology Applications in Biomedicine, IEEE EMBS International Conference, pages 83-88, Nov 2000.
- [8] N. Saranummi, I. Korhonen, M. van Gils, and S. Kivisaari. "Barriers limiting the diffusion of ict for proactive and pervasive health care". Proceedings of the IX MEDICON, Pula, Croatia, 4(29):1988-1991, Oct 2001.
- [9] A. van Halteren, R. Bults, K. Wac, N. Dokovsky, G. Koprnikov, I. Widya, D. Konstantas, V. Jones, and R. Herzog. Wireless body area networks for healthcare: the mobihealth project. Stud Health Technol Inform, 108:181-193, 2004.
- [10] U. Varshney. Pervasive healthcare and wireless health monitoring. Journal on Mobile Networks and Applications (Special Issue on Pervasive Healthcare), Springer, 12(2-3):111-228, June 2007.