



Robot For Serve Food and Medicines to Patients of Corona Virus in India

Prajakta Deshmukh¹, Snehal Bhagwat², Navnath Jogdand³, Sanket Manjule⁴, Prof. Sachine Date⁵

SPPU, SKNSITS Lonavala, Pune, India¹⁻⁵.

Abstract: This project is an innovative solution to robotics in health care and more important to the management and control of the spread of coronavirus disease (COVID-19). The main facilities of the robots are delivering food and medicine to minimize person-to-person contact and support in hospitals and similar facilities such as quarantine. This is supportive as well as helps to minimize the life threat to medical staff and doctors to an active role in the management system of the COVID-19 pandemic. The main point of this project is to highlight the importance of medical robotics in general and then to connect its utilization with the multipurpose robot of covid treatment. This is improving smart telemedicine. Which is also effective in similar situations.

Keywords: Medical robotics, Service robots, COVID-19 healthcare digitization, Corona-virus pandemic, COVID-19 Delivery Robots

1. INTRODUCTION

Our aim is to develop IoT Based Medical Assistant Robot. This robot consists of a medicine reminding and medicine providing system, Automatic hand sanitizer and IoT based Physiological Monitoring System (Body Temperature, Pulse rate, Oxygen saturation level).

On January 30, 2020, the World Health Organization (WHO) publicly declared the COVID -19 pandemic a “global emergency” because of the speed at which it spreads around the world. The virus shook the global economy and crashed the stock markets of many countries. After confirming the first case in Wuhan, China in December 2019, the coronavirus Pandemic quickly spread across the borders with China, causing numerous incidents in almost every country in the world. According to the WHO’s situational report the death rate is highest among older people compared to young ones, while male patients are more susceptible to risk compared to female patients in the same age group. Patients with pre-existing hypertension, diabetes, cancer, and chronic respiratory disease have a greater probability to pass away due to COVID-19 complications compared to patients without comorbid conditions.

Therefore, it is very important to use hand sanitizers, face masks, and practice social distancing to avoid viral infection, which can spread through sneezing, touching, and shaking hands. For the medical and health care community, the use of personal protective equipment (PPE) including N-95 face masks, hand gloves for covering against the spread of coronavirus is mandatory for close monitoring of COVID-19 patients [12]. Considering the current disastrous situation, robots are well suited for caring for COVID-19 patients thus replacing or at least sharing the workload of the medical staff in hospitals under over-saturated conditions. Some robots are used for medical support in hospitals today. Robots have been assigned multiple tasks to minimize the spread of COVID-19 such as utilizing them for food and medicine delivery in infected areas hazardous for humans. This study is one of the first studies, which highlights the importance of robotics in hospitals and health care facilities especially concerned with the COVID-19 outbreak. The purpose of this study is to explore strategic health care digitization innovation through robotics utilization in terms of global COVID-19 management perspectives [12].

Looking for the today's need We are assembling a project to protect yourself from viruses This includes building your own robot to maintain social distance. The robot delivers food and medicine with the help of a remote-control system We have added video conferencing functions in it. Because we can identify if something is available to the patient or how he is doing and we can treat them according to his needs and we can give whatever is needed to the patient with the help of robots. In this robot we have created a new robot using mechanical electrical electronics. Its sole purpose is to maintain a man-toman social distance and it does this with the help of robots It uses two geared motors, battery and battery indicator.



2. METHODOLOGY

2.1 SYSTEM DESIGN AND COMPONENTS UESD Table. 2.1 Rating and Components Used

SR. NO.	COMPONENTES USED	RATING OF COMPONENTS	NUMBER OF REQUIRED COMPONENTS
1.	Relay	5V D, 7A @250VAC	1
2.	4 Channel Remote Transmitter & Receiver	5 v, 10mA @ 5V	1
3.	Battery	12v 7.2Ah	2
4.	Motor	12v, 10RPM, 0.9A	2
5.	LM7805 IC	5V, 1.5A	1
6.	NRF24L01+PA+LN A	2.7V~3.6V, 2400MHz	1
7.	Arduino Nano	5v-6v, 150mA@5v ATmega328p	1
8.	Arduino Pro Mini	5v-6v, 150mA@5v ATmega328p	1

2.2. BLOCK DIAGRAM

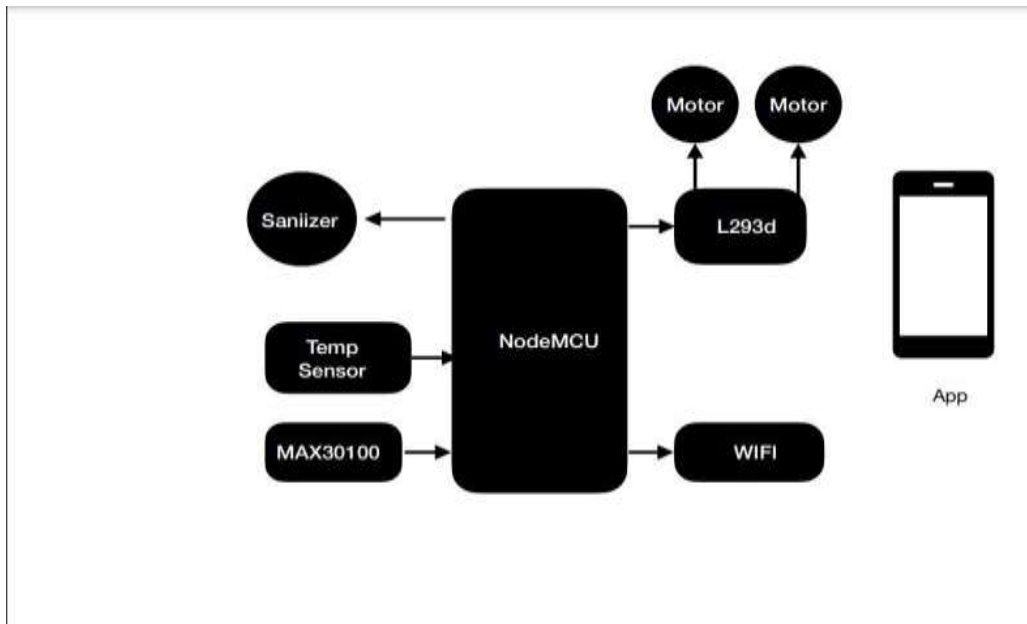



2.2.1. Transmitter

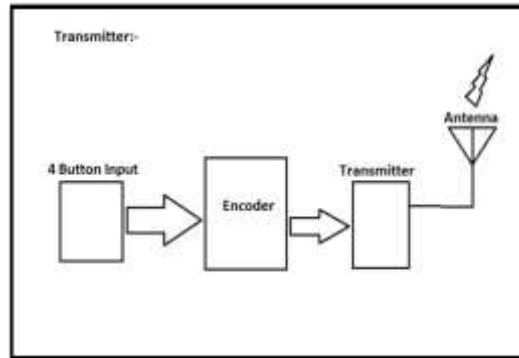

Fig. 2.2.1 Transmitter

This is block diagram of transmitter. In this diagram the four-button input is nothing but a remote. When we press the remote button, this input is given to the encoder. In encoder any type of data is converted into binary form. Then it passes to the transmitter. Transmitter transmit the signal to the antenna. Antenna receives the signal and it passes to the receiver.

2.2.2. Receiver

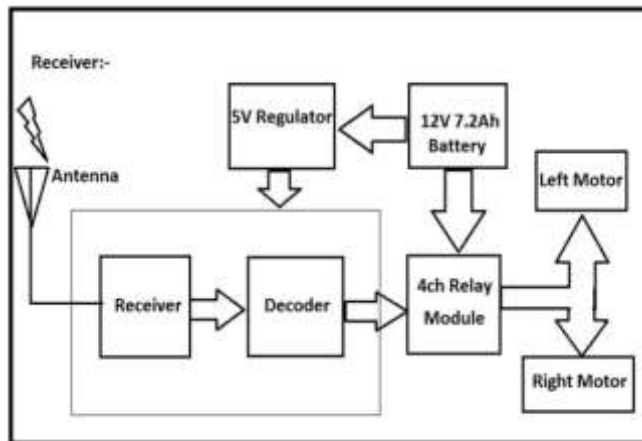

Fig.2.2.2 Receiver

Then next is receiver. Receiver receives the signal and then it passes to the decoder. In decoder decoding the signal to its original form which is encoded signal. Then it passes to the relay module. The relay module is used for switching purpose. Then the 5v regulator is used for receiver and decoder circuit because its capacity is 5v. then the battery is of 12v, 7.2Ah is used for relay module for moving and forwarding the motor.

2.3. CIRCUIT DIAGRAM

2.3.1. Relay Kit

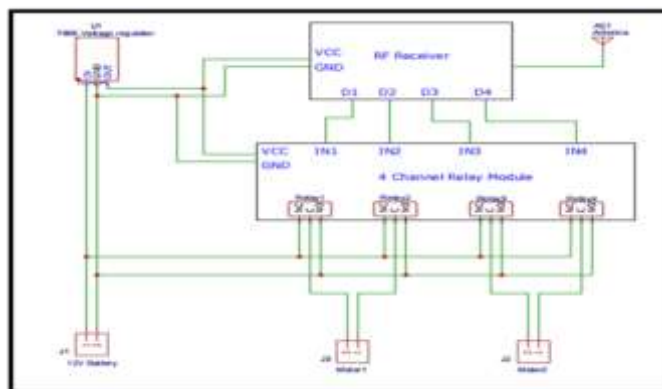

Fig.2.3.1 Relay kit



This fig shows the relay kit of our project. In this circuit there is input from the battery which is of 12v. this 12v input is given to the 7085-voltage regulator which converts 12v to 5v. this converted 5v supply which is required for RF receiver and 4 channel relay modules. The antenna which receives the signal or data and it is given to the RF receiver and this data is decoded in RF receiver and that 4-bit data is given to that 4 channel relays i.e., zero or one zero means OFF and one means ON. According to that the 12v battery supply is also given to the motors. There are four relays relay1, relay2, relay3 and relay4. Relay1 and relay2 are used for motor1 and relay3 and relay4 are used for motor2.

2.3.2. Temperature Sensor 1. Transmitter

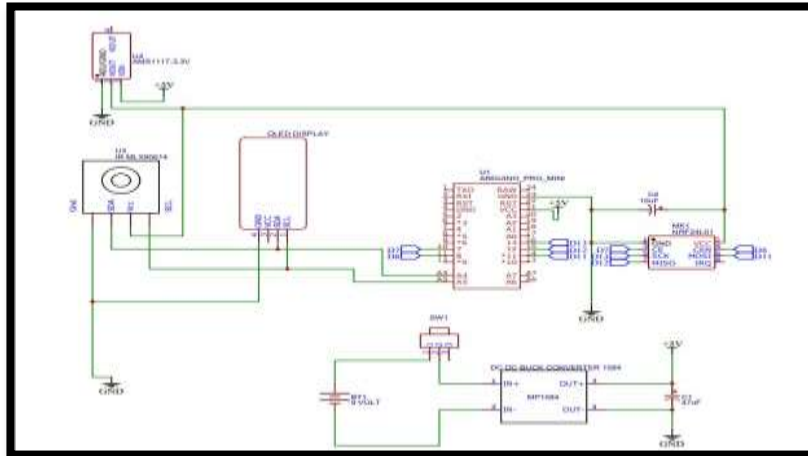

Fig.2.3.2.1 Transmitter

This is circuit diagram of temperature sensor. First, we will discuss about power circuit in power circuit there is 9V battery the supply is passes through the switch i.e., SW1 it is used for switching purpose then it is given to the buck converter which converts supply of 9V to 5V. This 5V supply is given to the capacitor i.e., of 47mf which is used for filtration and that 5V supply is given to the voltage regulator, OLED display & Arduino pro mini. The IR sensor requires 3.3V supply that’s why we are using voltage regulator which converts 5V to 3.3V which is given to the IR sensor and NRF24L01. There are four pins of IR sensor and OLED display which are the VCC, GND, SDA and SCL. SDA & SCL are the data pin and clock pin which is used for communication purpose. These two pins of the IR sensor and OLED display which are shorted and it is given to the A4 & A5 pin of the Arduino pro mini. The IR sensor and OLED display are communicated with the I²C protocol. The RF receiver and the Arduino pro mini is communicated with the SPI protocol.

2. Receiver

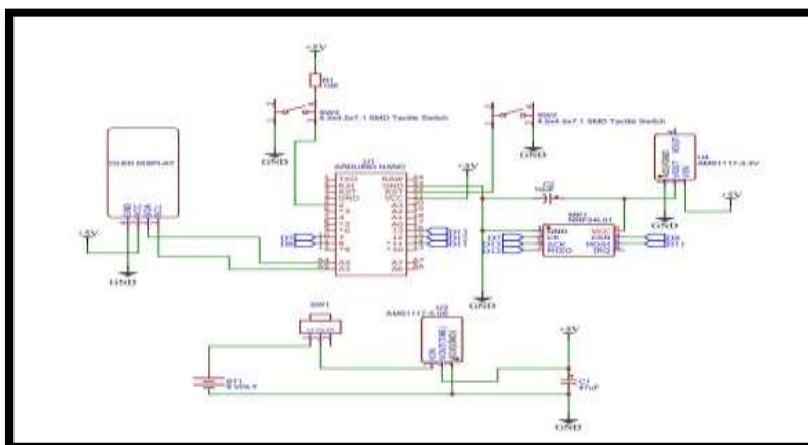

Fig.2 Receiver



This circuit is similar to the transmitter only the change is in this circuit we are using Arduino nano. In power circuit there is 9V battery supply is passes through the switch and given to the voltage regulator which converts 9V to 5V. The output of the regulator is filtered through the capacitor of 47mf and it is grounded. The 5v supply is given to the OLED display, Arduino nano & is also given to another voltage regulator which is required for NRF24L01 this voltage regulator converts 5V supply to 3.3V. The OLED display have the four pins i.e., VCC, GND, SDA & SCL. The data pin and clock pin are connected to the A4 & A5 pin of Arduino nano. In Arduino nano the reset pin is connected to the switch i.e., SW2 & the main switch SW3 is connected to pin 2. There is 10k registrar which is pulled up. Pull up means the register is directly connected to the 5V supply and the second pin is grounded. The NRF connections are also same as the transmitter and the NRF is used for wireless temperature display.

3. ADVANTAGES, DISADVANTAGES AND APPLICATIONS

A. ADVANTAGES

- Break the chain initiate.
- Special facility of reusing via charging.
- Contactless medical facilities.
- Did not come directly in contact with patient.
- Encourage the use of robots to support social distancing.
- Robots can work in hazardous environments.
- Robots need no environmental comfort.
- Protect yourself from COVID-19 situations.
- It can be used in Military purpose.
-

B. DISADVANTAGES

- In case of battery discharging the system can failures of supply.
- They have no emotion.

C. APPLICATIONS

- It can be used in hospitals.
- It can be used in quarantine area.
- It can be used contactless food delivery to patients.
- Boring and unpleasant tasks.
- It can be used repetitive tasks.
- It can be also used in residential, commercial and industries.

4. CONCLUSION

- In this project, we have presented a robot for serving food and medicines to patients. Who are suffering from COVID-19.
- Also, in this project, we have implemented a temperature wireless sensor.
- We concluded that moving towards high technology the upcoming model is a robot that provides food and medicine to the patients.
- This robot helps a doctor to avoid direct contact with patients.

5. REFERENCES

- [1] T. Yukawa, N. Saito, W. Matsuoka, A. Kanda, and H. Okano, "Autonomous control of care and welfare robot," 2004 1st IEEE Tech. Exhib. Based Conf. Robot. Autom. Proceedings, TExCRA 2004, pp. 53–54, 2004, doi: 10.1109/texcra.2004.1424993.
- [2] Y. Hada, H. Gakuhari, K. Takase, and E. I. Hemeldan, "Delivery service robot using distributed acquisition, actuators and intelligence," 2004 IEEE/RSJ Int. Conf. Intell. Robot. Syst., vol. 3, pp. 2997–3002, 2004, doi: 10.1109/iros.2004.1389865.
- [3] S. Thiel, D. Häbe, and M. Block, "Co-operative robot teams in a hospital environment," Proc. - 2009 IEEE Int. Conf. Intell. Comput. Intell. Syst. ICIS 2009, vol. 2, pp. 843–847, 2009, doi: 10.1109/ICICISYS.2009.5358271.
- [4] J. Hu et al., "An advanced medical robotic system augmenting healthcare capabilities - Robotic nursing assistant," Proc. - IEEE Int. Conf. Robot. Autom., pp. 6264–6269, 2011, doi:



10.1109/ICRA.2011.5980213.

- [5] F. Peleato, M. Prabhakar, and J. H. Kim, "Smart global positioning system for autonomous delivery robots in hospitals," Proc. - 29th South. Biomed. Eng. Conf. SBEC 2013, pp. 141–142, 2013, doi: 10.1109/SBEC.2013.79.
- [6] H. S. Ahn, M. H. Lee, and B. A. Macdonald, "Healthcare robot systems for a hospital environment: CareBot and ReceptionBot," Proc. - IEEE Int. Work. Robot Hum. Interact. Commun., vol. 2015-Novem, pp. 571–576, 2015, doi: 10.1109/ROMAN.2015.7333621.
- [7] Y. Hirata, Y. Sugiyama, and K. Kosuge, "Control architecture of delivery robot for supporting nursing staff," 2015 IEEE/SICE Int. Symp. Syst. Integr. SII 2015, pp. 345–351, 2016, doi: 10.1109/SII.2015.7404944.
- [8] S. Jeon and J. Lee, "Vehicle routing problem with pickup and delivery of multiple robots for hospital logistics," Int. Conf. Control. Autom. Syst., vol. 0, no. Iccas, pp. 1572–1575, 2016, doi: 10.1109/ICCAS.2016.7832511.
- [9] J. Han, H. J. Kang, and G. H. Kwon, "Understanding the servicescape of nurse assistive robot: The perspective of healthcare service experience," 2017 14th Int. Conf. Ubiquitous Robot. Ambient Intell. URAI 2017, no. July 2013, pp. 644–649, 2017, doi: 10.1109/URAI.2017.7992693.
- [10] J. Liu, F. Zhou, and L. Yin, "Design of a Service Robot Cloud Service Platform," 2019 4th AsiaPacific Conf. Intell. Robot Syst. ACIRS 2019, pp.124–128, 2019, doi: 10.1109/ACIRS.2019.8936034.
- [11] T. T. Nguyen, "Artificial Intelligence in the Battle against Coronavirus (COVID-19): A Survey and Future Research Directions," no. August, 2020, doi: 10.13140/RG.2.2.36491.23846/1.
- [12] Z. H. Khan, A. Siddique, and C. W. Lee, "Robotics utilization for healthcare digitization in global COVID-19 management," Int. J. Environ. Res. Public Health, vol. 17, no. 11, pp. 1–23, 2020, doi:10.3390/ijerph17113819.