



SMART CAR PARKING SYSTEM USING RASPBERRY PI

Dr. VINAYAK BHARADI¹, RAJ NAKHAREKAR², SHUBHAM MANGORE³, VISHAL SAWANT⁴

Professor and HOD, Department of Information Technology, Finolex academy of Management and Technology, Ratnagiri, Maharashtra, India¹

U.G. Student, Department of Information Technology, Finolex academy of Management and Technology, Ratnagiri, Maharashtra, India²⁻⁴

Abstract: In interconnection and automation of different physical gadgets, vehicles, home machines and different things, the internet of things (IoT) innovation plays a critical role. These objects associate and deal information with the assistance of software, different sensors, and actuators. A human's standard of life and living are improved with this automation of gadgets, which is a forthcoming need. In this paper we talked about a similar requirement for instance, a smart car parking system which empowers a driver to discover a parking area and a free slot in that parking area inside a city. This paper focus on decreasing the time squandered on discovering parking area. This in turn diminishes the fuel utilization and way of life. With the exponential increment in the quantity of vehicles and total population, vehicle accessibility, use out, about starting late, finding a space for parking the vehicle is turning out to be increasingly more troublesome with realizing the amount of conflicts, for example, automobile overloads. This paper is connected to making a trustworthy system that accept authority over the undertaking of recognizing free slots in a parking area and keeping the record of vehicles left in an extremely methodical way. The predicted system decreases human effort at the parking area generally, for example, in case of looking of free slots by the driver and calculating the portion for each vehicle using parking area. The different advances engaged with this system are vehicle unique proof utilizing RFID labels. payment count is done based on time of parking.

Keywords: IOT, RASPBERRY PI, RFID, POWER SUPPLY, LCD.

INTRODUCTION

RFID is an automatic identification and data capture technology, in which the data transfer between the reader and tagged module is done by radio frequency waves. The objective is to Identifying, tracking and monitoring objects. RFID is known for a long time has not been used frequently because it is a bit expensive than other technologies. In RFID, the objects are identified using tags. Each tag has a unique tag-id. The tag-id can be provided by the manufacturers or can be provided by the programmer of the system. Generally, two types of tags are available like passive tag and active tag. Passive tags are less expensive compared to active tags and widely used. But passive tags do not have a battery inside them and they are powered by the antenna. In the active tags, there is a battery inside them that's why they are expensive than those passive tags and also they have more memory space than passive tags. The purpose of using RFID for parking system is to provide simple solutions to the problem that are encountered in the parking lots, to decrease the workload and to maintain the records of vehicles. The main components of our system are tags, antenna, reader, barriers and the software we are using. The purpose and aim of the software are to maintain the records and to perform various operational tasks. The problem of space in the parking lot should be solved programmatically by keeping the count of the total number of space available and the total number of vehicles that have entered the parking lot and for how much time vehicle stay in parking lot. In this way, the time that is being wasted to search for a parking space can be avoided. The problem slow verification is also being solved as the manual identification takes more time that tag identification and also logs and records can be maintained for a long time period as there is no use of manual registers and the data is maintained in form of files that can be utilized further according to the system's requirement. We can easily charge the owner accordingly. Automatic payment will be done.

LITERATURE SURVEY

Project Title : Smart Car Parking with Monitoring System

Abstract— Nowadays, the total amount of traffic is increased rapidly and parking space getting smaller. It's to design a drive less car by using RTOS (Real Time Operating System) and a Smartphone. It is motivated to configure the guidance



system of a flexible (Automated Guided Vehicle) AGV. The driver finds very difficult to park their vehicle in a narrow garage, so it helps to park the vehicle using Smartphone via Bluetooth with the range of 100 m, ranges between the car and the Smartphone and GPS (Global Positioning System) is also used to know the location. This GPS system will help the user to easily identify the car location. "Car Assist" technology is used to monitor the car driving path and the things happening around the car can be viewed in the smart phone via GPS. It supports live time preview to monitor the car parking garage. The users need not to be present inside the car like some previous generation systems. The proposed work is compared with bench work results and yield very less time to monitor and park the vehicles against the existing system.

Project Title: Automatic Car Parking System with Visual Indicator along with IoT

Abstract— this paper focuses on the concept of car parking detection mechanism using the ultrasonic sensor, in combination with the usage of Internet of Things i.e. sending the status of the parking slot to the Internet. Through which the user at any place in the world can see which parking slot is empty and where to park. This is done by sending the data of ultrasonic sensor through our Wi-Fi module that is ESP8266 to any open source easy to use IOT platform that uses HTTP to display our data (thingspeak.com in this case).

Project Title: Automatic Parking Space Detection System

Abstract—Searching a suitable parking space in populated metropolitan city is extremely difficult for drivers. Serious traffic congestion may occur due to unavailable parking space. Automatic smart parking system is emerging field and attracted computer vision researchers to contribute in this arena of technology. In this paper, we have presented a vision based smart parking framework to assist the drivers in efficiently finding suitable parking slot and reserve it. Initially, we have segmented the parking area into blocks using calibration. Then, classify each block to identify car and intimate the driver about the status of parking either reserved or free. Potentially, the performance accuracy of recommended system is higher than state of the art hardware solutions, validating the supremacy of the proposed framework.

Project Title: Smart Parking System with Automatic Cashier Machine Utilize the IoT Technology

Abstract—The difficulty of finding car parking spot has become one of main consideration to create this paper and focusing on develop our proposed smart parking system. Other than that, the utilization of internet of things (IoT) technology has become one of great technology that match for complex system with a minimal use of hardware. With the implementation of IoT based on cloud computing, several smart devices, and also smart automatic machine, the concept of smart parking system are expected to be able to provide services for car parking spot searching and car parking spot allocation through the mobile application.

SYSTEM DESIGN

Block Diagram

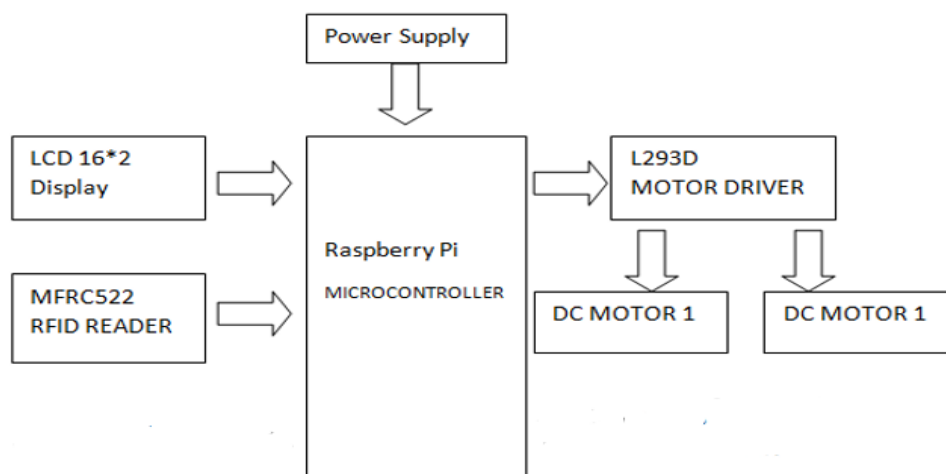

**SYSTEM COMPONENTS****A. RFID READER MFRC522**

RFID reader module is used to read RFID cards which work at 125 kHz. When RFID card comes in the range of the reader, the unique data in the card is received by the reader in the form of an RF signal. The reader then transmits this data in byte form on its serial transmit pin. This data can be read by a microcontroller using UART communication or can be viewed on the PC terminal.

B. RFID Tag

Radio Frequency Identification tag (RFID tag) uses electronic data, to exchange information between the tag and reader module. Most of RFID tag contains at least two parts. The integrated circuit (IC) performs operations like information storage, processing, modulation and demodulation of the (RF) radio-frequency-signal and other specialized functions. The 2nd one is the antenna for transmitting and receiving signal. The RFID tags are mainly two types, one is an active tag which contains a battery itself thus signal can be transmitted by it automatically and the second one is a passive tag which does not contain any battery external source is required to transmit signal from this type of tags.

C. Raspberry pi

The raspberry pi board comprises a program memory (RAM), processor and graphics chip, CPU, GPU, Ethernet port, GPIO pins, Xbee socket, UART, power source connector. And various interfaces for other external devices. It also requires mass storage, for that we use an SD flash memory card. So that raspberry pi board will boot from this SD card similarly as a PC boots up into windows from its hard disk. Essential hardware specifications of raspberry pi board mainly include SD card containing Linux OS, US keyboard, monitor, power supply and video cable. Optional hardware specifications include USB mouse, powered USB hub, case, internet connection, the Model A or B: USB Wi-Fi adaptor is used and internet connection to Model B is LAN cable.

D. LCD Display

An electronic visual display made up of liquid crystals. In this project, a 16X2 display is used. This kind of displays can be found in a wide range of applications in the industries.

E. L293D Motor driver

L293D is a typical Motor driver or Motor Driver IC which allows DC motor to drive on either direction. L293D is a 16-pin IC which can control a set of two DC motors simultaneously in any direction. It means that you can control two DC motor with a single L293D IC. Dual H-bridge Motor Driver integrated circuit (IC). The L293D IC receives signals from the microprocessor and transmits the relative signal to the motors. It has two voltage pins, one of which is used to draw current for the working of the L293D and the other is used to apply voltage to the motors.

F. DC Motor

DC motor is a rotational electrical device in which electrical energy is converted into mechanical energy. It is used to control the barrier of the parking lot. It is interfaced with the microcontroller and takes command from the microcontroller to rotate.

IMPLEMENTATION**WORKING PRINCIPLE**

In this proposed system the check-in and check-out of the vehicle are maintained and controlled using a database. For the design of the system, both hardware and software are being used. Information of all the vehicles are stored in the database and the respective tags and their tag ids are provided to the users, so all the information can be accessed by the system. When the vehicle checks in, the reader reads the data of the tag. If there is no tag on the vehicle than the barrier will remain closed. Now the reader will read all the information about the tag and transfer that information to the software. Now that software compares the information of tag with the database and if the id of tag matches than barrier gate will open and if the id doesn't match than barrier will not open. When the vehicle goes out from the parking lot, the identification information of the vehicle is searched in the database. If it is an authorized vehicle and does not have unauthorized access, then only the vehicle will be allowed to check out otherwise the gate will not open.

1. When the authorized user comes at the entry gate and put their card to the reader



2. We will check user information into database and balance in his account.
3. If user is not in database barrier remains close.
4. If user present and balance is not in his account, then also barriers remain close.
5. Otherwise user tags the card to the reader automatically the vehicle count will count and the time will start for the vehicle
6. We keep user information in our database like for how many time users stay in parking slot. Its id number, entry time, exit time, date, charges.
7. When user want to leave the parking space then ask the user to put you're to the reader
8. When the user tags the card to the reader automatically the money would be deducted from the Account according to the time he spends
9. Entry and exit time is used for count the time of the vehicle.
10. When the user leaves the space our counter counts the vehicle in the parking space and how many vehicles are left from the parking space
11. All history of parking area is maintained in our database.

FLOWCHART

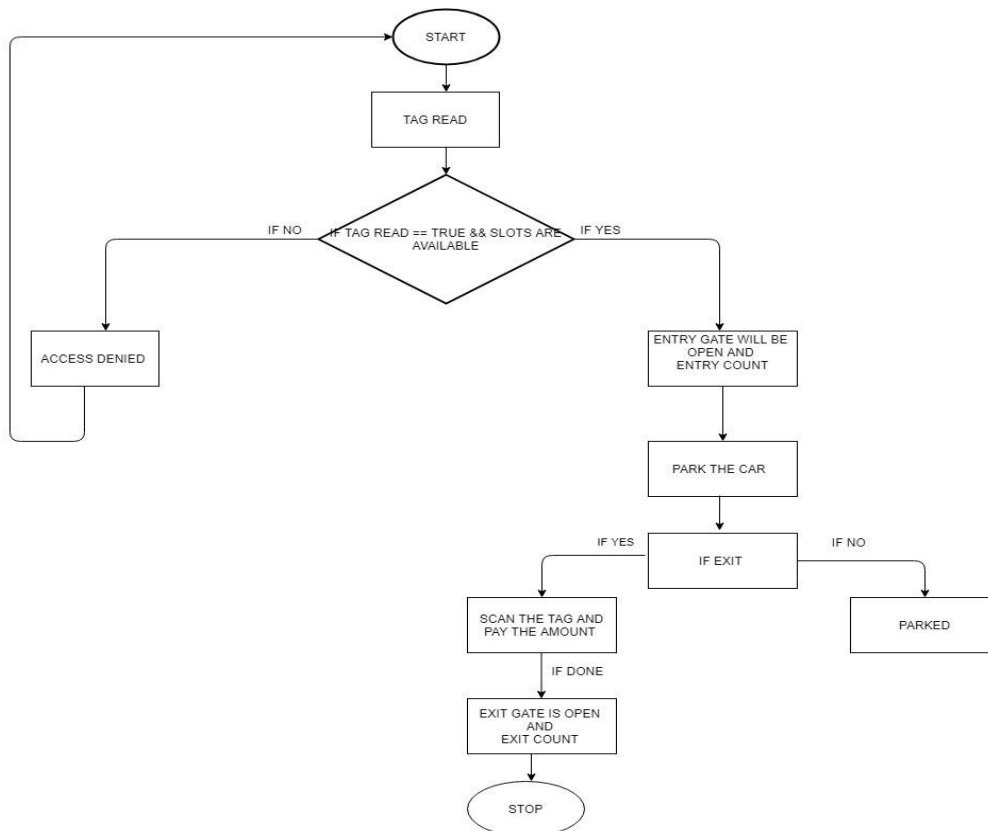

RESULT

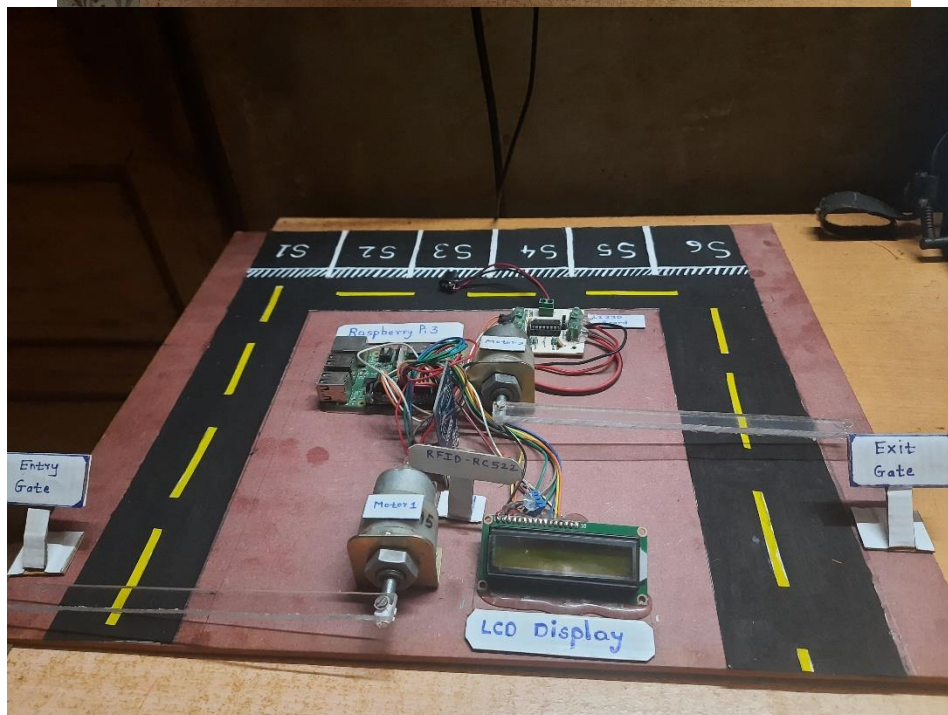
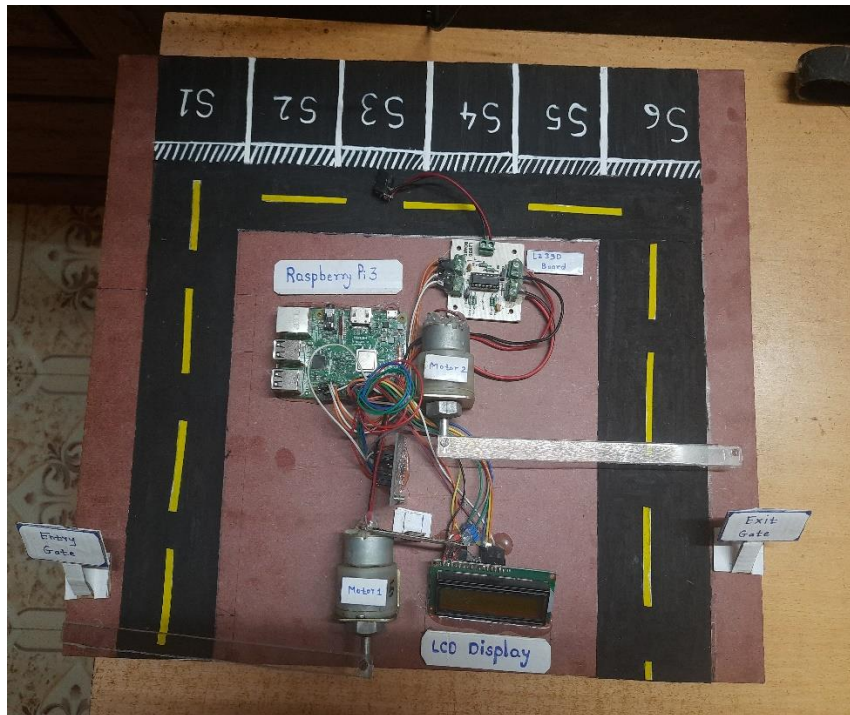

1. When the authorized user comes at the entry gate and put their card to the reader
2. We will check user information into database and balance in his account.
3. If user is not in database barrier remains close.
4. If user present and balance is not in his account, then also barriers remain close.
5. Otherwise user tags the card to the reader automatically the vehicle count will count and the time will start for the vehicle



6. We keep user information in our database like for how many time users stay in parking slot. Its id number, entry time, exit time, date, charges.
7. When user want to leave the parking space then ask the user to put you're to the reader
8. When the user tags the card to the reader automatically the money would be deducted from the Account according to the time he spends
9. Entry and exit time is used for count the time of the vehicle.
10. When the user leaves the space our counter counts the vehicle in the parking space and how many vehicles are left from the parking space
11. All history of parking area is maintained in our database.

CONCLUSION

In this project, it has been proved that using RFID tags and reader with a database we can develop a secure and well managed parking lot. This project not only provides atomized parking but we can also manage records in a better way. By using a centralized database system easy administration and access are possible. The admin can easily keep a check on the vehicles that are entering and leaving according to the date and timing. If this system is installed in some university or school for the teacher's parking than we can expand the system to keep the track the attendance of teachers by keeping the track of vehicles that are present in the parking lot. By using this system, personnel cost will cut off and the traffic jam problem will be solved by the faster check-in and checkouts. By expanding this system we can also use this system to collect revenue for parking in an efficient manner. In this system, we can use the LED display which can keep an account of the number of cars or the vacancies left in the parking lot.

ACKNOWLEDGMENT

Report is on the topic: "SMART CAR PARKING SYSTEM USING RASBERRY PIE" All the Relevant and essential details are included in the paper. At the beginning we have given the summarized details of the project which we are building and we have also proceed details about how the project is going to be implement and which technologies we are going to use to develop this project.

We are thankful to **DR.VINAYAK BHARADI** who guides us and helps in preparing the paper .We thank him for providing us the confidence and most importantly giving us the track regarding the project topic whenever we needed it.

REFERENCES

- [1] <http://www.rhydolabz.com/components-microcontrollersc-172-192/pic16f877a-microcontrollerpdip-p-199.html>
- [2] <http://www.scienceabc.com/innovation/what-is-range-of-the-bluetooth-and-how-can-it-be-extended.html>
- [3] www.technopol.biz/shop/usefiles/editor/file/manual.pdf
- [4] <http://www.techwallr.com/articles/features-of-bluetoothtechnology> [5] blog.assettracker.com/vehicle-tracking-system-features.
- [6] <http://www.google.com/search?q=gps+features+and+functions&sa=X&ved=0ahUkEWio4fnU+bAhwjQ48KHAJQQ11sgEoAA&biw=1366&bih=613>.
- [7] H. Fazlollahtabar, B. Rezaie, and H. Kalantari "Mathematica programming approach to optimize material flow in an AGV-based flexible job shop manufacturing system with performance analysis, "International Journal Advanced Manufacturing Technology., volume 51, no.9, pp.1149-1158, 2010.
- [8] Tingxin Yan, Baik Hoh, Deepak Ganesan, Ken Tracton, Toch Iwuchukwu and Juong-Sik Lee. A crowd sourcing based parking reservation system for mobile phones. Technical Report UM-CS-2011-001, Department of Computer Science, University of Massachusetts, Amherst MA, 2011.
- [9] Donald C. Shoup. Cruising for parking. Transport Policy, 13(6):479 – 486, 2006.
- [10] https://www.google.com/search?q=pin+diagram+for+PIC16F877A&safe=strict&source=lnms&tbm=isch&sa=X&ved=0ahUkEWjFjvr8n4LcAhWHp48KHUcpAi0Q_AUICigB&biw=1366&bih=662#imgrc=N17FtuQfzMrbPM

Style of listing references of some standards are as below;

ASME standard Book,

- [1] Merritt, H. E., 1971, *Gear Engineering*, Pitman, New York, pp. 82–83.



Journal Paper,

[2] Arakere, N.K., and Nataraj, C., 1998, "Vibration of High-Speed Spur Gear Webs," ASME Journal of Vibration Acoustics, 120(3), pp.791–800. **Proceeding Paper,**

[3] Stewart, R. M., 1977, "Some Useful Data Analysis Techniques for Gearbox Diagnostics," Proceedings of the Meeting on the Application of Time Series Analysis, ISVR, University of Southampton, Southampton, UK.

Thesis,

[4] Kong, D.W., 2008, "Research on the Dynamics and Fault Diagnosis of the Large Gear Transmission Systems," Ph.D., thesis, JiLin University, Changchun, China.

IEEE standard Book,

[1] J.F. Curtis, (Ed.), *Processes and Disorders of Human Communication*. New York: Harper and Row, 1978.

Journal Paper,

[2] J. Schroeter and M.M. Sondhi, "Techniques for estimating vocal-tract shapes from the speech signal," *IEEE Trans. Speech Audio Process.*, vol. 2, no. 1, pp. 133–150, 1994. **Proceeding paper,**

[3] J. M. Pardo, "Vocal tract shape analysis for children," in *Proc. IEEE Int. Conf. Acoust., Speech, Signal P*