



# A Review Paper on Sensors and Comparative Study between Node MCU and Arduino UNO

Kamna Singh<sup>1</sup>, Karan Bajaj<sup>2</sup>, Chetan Verma<sup>3</sup>, Mayank Bhardwaj<sup>4</sup>, Rohan Mathpal<sup>5</sup>

<sup>1</sup>Faculty, Inderprastha Engineering College, Ghaziabad, India

<sup>2,3,4,5</sup>Student, Inderprastha Engineering College, Ghaziabad, India

**Abstract:** This paper provides a comparative study between node Mcu and Arduinio micro controller board. Node Mcu Board are used for implementing Internet of things applications. IoT IoT is technologies which can be connect with physical objects to Internet. IoT technology can be used with Sensors and any of the electrical or mechanical objects. This paper provides some algorithm such as how IR sensor connected with physical objects. Paper proposed some algorithms which shows that how different sensors connected with physical devices and provides desired solutions and an approach in the form of algorithm (step by step solution) to connect Node MCU ESP 8266 (development board or firmware) with Arduino IDE which provide low power battery operated applications or prototyping of IoT devices. This paper also provides a comparative analysis between NodeMCU development board and Arduino UNO microcontroller board. These are the development boards to generate IoT based applications.

**Keywords:** Internet of Things, Arduino UNO, Node MCU, IR Sensor, DHT11

## I. INTRODUCTION:

IoT provides a technology based applications which connects and communicates physical devices or physical objects with other physical objects via internet. There are four main components of IoT i.e. Sensors, Connectivity, Data Usage and User Interface. The first component is sensors, Sensor is a device which produces some physical characteristics after sensing its surrounded environment. Such as temperature sensor and pressure sensor produces observed result of pressure or temperature by its surrounded environment. Second component is connectivity, with sensor and web, there are some protocols and technologies used to resolve this issue. Some IoT enabled technologies are BLE (low power Bluetooth), RFID (Radio frequency identification), LPWAN(low power wide area network). Third component is the data usage i.e. all the pertinent data are on cloud storage and need some processing on it, therefore physical objects which is connected with the internet via development board (Node McU or Arduino UNO) to Arduino IDE.

In other words we can say that IoT hardware (sensor and development kit) interacts with IoT software (e.g. Arduino IDE) with the help of internet and data processing will be done using cloud storage. Fourth component of IoT is user interface; it defines how and when the user gets the alert messages.

Internet of things uses different wireless technologies

to connect anything to anything and produces desired output and compare it with the predefined output. .

Following are the brief description of Arduino Uno and Node MCU development board specifications.

### Comparative Analysis of Node MCU and Arduino UNO Development Board

- i) Node MCU ESP 8266 is an open source firmware and Arduino UNO development board is microcontroller board based on 8 bit ATmega328P.
- ii) Current consumption in deep sleep mode in Node MCU is 0.5  $\mu$ A while in Arduino UNO is 35 mA.
- iii) In both the boards power supply is 7V to 12V.
- iv) RAM size in node MCU is 128KB and in Arduino UNO RAM size is 2KB.
- v) Node MCU uses 4MB ROM as a flash memory (which tells about program space) and in Arduino UNO flash memory size is upto 32kB.
- vi) Arduino UNO have USB type B connector and in Node MCU micro USB port.
- vii) Arduino UNO board size is bigger than node MCU.
- viii) In node MCU there are 11 or 13 digital I/O pin pins while in Arduino there are 14 digital I/O pin.

#### 1.1 Arduino UNO

Arduino UNO is a microcontroller board based on 8 bit ATmega328P microcontroller. it has 14 digital pins and 6 analog pins. Analog pins accept analog inputs such as temperature, pressure etc. analog variables represents continuous or physical quantity. Arduino UNO microcontroller board operating voltage is 5 V and range of the input voltage is 6-20 V. therefore this development board is useful for low voltage devices and suitable for IoT enabled devices.



### 1.2 Node MCU

Node MCU is a software that comes installed in an ESP 8266 and uses the Lua programming language but the ESP 8266 that comes with Node MCU can be programmed. Here node represents node as physical objects which is connected with the sensor and MCU refer as microcontroller unit.

It consists of circuit board (with 30 digital pin and 1 analog pin), which can be programmed by readymade software. Node MCU board size is 49 mm\*26mm and pin spacing is 0.9'' (or 22.6 mm), clock speed is 80 MHz. its temperature range is -40C to -125 C. there are total 12 pins, 11 digital pins and 1 analog pin.

Node MCU development board contains 2.4 GHz Antenna, ESP 12E chip, 3.3 voltage regulator, micro USB port, CP 2102 USB to TTL converter and reset button. there are 4 power pins. Generally node MCU operating voltage is 3.3 Volt.

### 1.3 Sensors:

Sensors is an equipment used to compute or measure the physical properties such as distance, pressure, humidity, temperature and provide desired accurate or sometimes approximate result.

Various sensors such as automotive sensor, fluid property sensor, digital component sensor, flow sensor, force sensor, humidity sensor, mass air flow sensor, photo optic sensor, piezo film sensor, position sensor, pressure sensor, rate and inertial sensor, speed sensors, temperature sensor, torque sensors, traffic sensors, ultrasonic sensor, vibration sensor, water level sensor etc. One of the real time examples of sensors applications is in military aircraft. In the military aircraft there is a feature of an autopilot mode, in which computer is attached to the various sensors (such as position, height, speed, temperature, location etc.) and then as desired aircraft engine will be automatically on and flaps motors, wings and other equipment will automatically be enabled.

Computer takes data from sensor then it provides control signals to different ports of aircraft and then it runs on autopilot mode.

### 1.4 Programming Node MCU ESP 8266 with Arduino IDE

The Node MCU ESP8266 development board can be easily programmed with Arduino IDE

(Arduino integrated Node MCU ESP 8266 microcontroller development board gives one more capability i.e. it has automatically enabled WiFi solution whereas Arduino UNO microcontroller board does not have inbuilt WiFi capability).

## 2. LITERATURE REVIEW:

IoT can be described as interconnection and communication between the different physical and electronic objects. All objects require connectivity. It does not require that every object should be able to handle internet.

In other words, internet capability of objects, which is connected with IoT development boards is always not necessary.[1]

As IoT data is very sensitive data, so many web applications attacks are possible and we have to protect our device and physical objects from it[3]

Although there are so many protocols which provide services and resolve connectivity issues between user interface and physical objects.

Actually till now, Internet of Things have not any common architecture or standard architecture that's why some security vulnerability occurs in different layers in IoT architecture. Even though there are layered architecture which contains 4 or 5 layers but still it is not universally accepted.

Therefore finding and overcoming the attacks of IoT devices is a major challenge for researchers and scientists both.[4]

There is a complex relationship between user, service provider, physical object, IoT enabled development board (NodeMCU or Arduino UNO), therefore identity identification is the measure challenge while developing IoT based applications. The measure security measures such as authentication, integrity, confidentiality and non-repudiation required to handle security vulnerabilities.[5]

IoT based applications are connected with small devices. These devices may be electrical, electronic or mechanical devices or any other physical object. Therefore it is required that low power technologies should be used. Low power, low energy set of rules required which can be processed with very low power and provide desired outcomes. Zigbee, BLE (Blue tooth Low Energy), RFID, 6LoWPAN (IPv6 Low power wireless personal area network). Provides low power connectivity solutions.[6]

## IV. ALGORITHMS TO CONNECT SENSORS WITH NODE MCU

In these proposed approaches, we are trying to connect and implement different types of sensors via Node MCU development board with Arduino IDE and create some IoT based applications.

Following proposed approach is used to analog signals by through digital pin mode using node MCU.delay can be set as1000.

#### 4.1 Digital to Analogwrite

Proposed algorithm shows how to connect Node McU to internet through the computer and set analog signal in Node MCU using IoT. This particular algorithm describes the connection between NodeMCU and Arduino IDE with initialization of digital pins and converts the input signal into analog signal. analogWrite() function is used to generate steady square wave of the specified duty cycle until the next call

#### 4.1 Connectivity with IR Sensor :

Here we are proposing that how to connect infrared sensor with internet using node MCU.Infrared Sensor is used for object detection. If any physical object (such as human or any physical thing) comes in front of IR Sensor then it detects that physical thing.

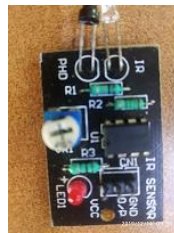

Fig 1: IR Sensor

#### 4.3.1 Algorithm to connect IR sensor with Node MCU

1. start
2. set D2 pin as output in Node MCU
3. set D1 pin as input in node MCU
4. call digitalWrite function (S)
  - if S=high , then set D2 pin as high
  - else set D2 pin as Low

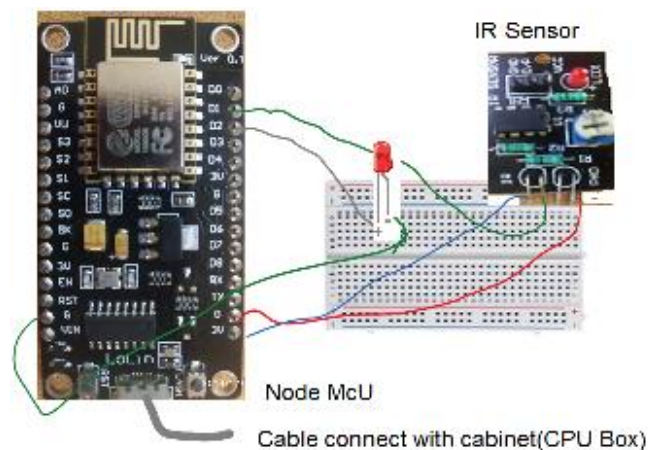

Fig 2: IR Sensor Connected with Node McU

**Explanation:** Node McU have 3.3 V , so this pin is connected with IR Sensor. Node MCU digital pin is connected with IR sensor and and D2 pin is connected to LED +ve pin. The -ve pin of LED is connected with the ground in node MCU circuit board. When the Node MCU is connected with the internet through the cable then after desired output will be achieved.

#### 4.4 Algorithm for Analog input with light dependent register(LDR)

This algorithm shows how to connect light dependent resistor to internet via Node MCU board.LDR is also called photoresistors and it detects light. Light dependent resistor, resistance is inversely proportional to intensity of light.  
 $LDR \text{ resistance} = 1 / \text{intensity of Light}$

It means when intensity of light decreases then resistance value of LDR sensor will increases.

start

1. initialize the serial input as 9600.(i.e.the baud rate for serial input)
2. set A0 pin as input
3. set S as analogRead with input pin A0
4. output displayed on serial monitor
5. Delay can be set as 500.

**Explanation:** Node MCU as only one analog pin while Arduino IDE circuit board contains 6 analog pins.

In Node MCU , when user required to read analog input , user have to use analogRead() function. And get result on serial monitor.

As we discussed earlier Node MCU circuit board has only one analog pin , here it will be connected with input. We can also set the delay function. so that achieved output will not be displayed continuously.

#### 4.5 Humidity and temperature sensor

DHT11 humidity and Temperature sensor, operating voltage is 3 to 5Volt and current consumption is 2.5mA.this sensor detects humidity and temperature of the surrounded environment and produces output on serial monitor( arduino IDE).



Fig 3: DHT 11 Humidity Sensor

##### 4.5.1 Algorithm for Humidity and Temperature Sensor

1. Set digital pin D2 as DHT11
2. Initialize serial input with 9600 baud.
3. Initialize DHT
4. Read temperature with serial input
5. Read humidity with dht variable with serial input
6. Delay can be set till 3000

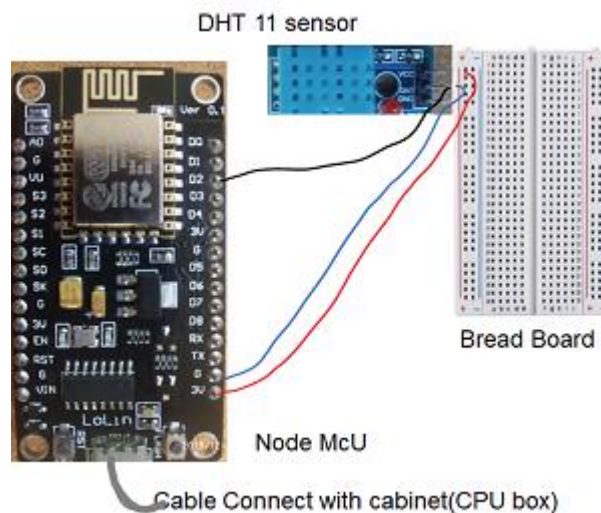

Fig 4: humidity Sensor Connected with Node MCU

Humidity and Temperature is also called DHT 11 Sensors.

**Explanation:** In this proposed algorithm we describe how the Humidity and Temperature sensor works. For the connection, Node MCU 3V pin is connected to the V (Voltage) pin of DHT 11 sensor. Ground of DHT11 pin is directly connected to the Node MCU ground pin using Breadboard. Digital pin D2 of Node MCU circuit board is connected to the DHT11 sensor.

Output can be display in serial monitor while connecting Node MCU to computer via cable.

Delay can also be set. Therefore user can get the current room temperature and humidity measurement.



#### 4.6 Algorithm for Ultra sonic sensor for measuring distance

When Sound waves emitted by ultrasonic sensor travels and reach the object and reflect to the original source, then by calculating of the total distance travels will be the actual distance from source object to destination object.

##### 4.6.1 Algorithm:

1. Initialize set up
2. Initialize serial input with 9600 baud
3. Initialize D2 pin as output and D4 pin as input
4. digitalWrite as D2 pin set as Low
5. delay can be set in microseconds
6. duration variable set as HIGH with D4 pin.
7. Distance variable set as duration/29/2
8. Call serial monitor by using Serial.println ()

Here we used air speed as 29 microsecond/cm.

## V. CONCLUSION

This paper presents different algorithms for the connection between different types of sensors (such as IR sensor, Ultrasonic sensor, Temperature and Humidity sensor) with arduino IDE by using Node MCU. We also provide the wireless solution for IoT enabling devices. This paper also provides a brief description of Node MCU and Arduino UNO development board and explain the brief introduction of sensor and its types. In this paper we are trying to write the step wise step method to provide connectivity with IoT technology and development board Node MCU. Proposed algorithms are algorithm for glowing LED, algorithm to set wireless connection , algorithm for infrared sensor(IR Sensor), algorithm of connect light dependent resistor, algorithm for humidity and temperature Sensor(DHT11) and algorithm to connect ultrasonic sensor via Node MCU board.

There is also a comparative analysis of Node MCU ESP 8266 and Arduino UNO ATmega328P development board used for developing IoT based applications.

## REFERENCES

- [1] AbdelRahman H. Hussein, "Internet of Things (IOT): Research Challenges and Future Applications", (IJACSA) International Journal of Advanced Computer Science and Applications, Vol. 10, No. 6, 2019
- [2] Amine Rghioui, Abedlmajid Oumnad, Internet of Things: Visions, Technologies, and Areas of Application, Automation, Control and Intelligent Systems(ACIS) Sciencepublishinggroup,,ISSN: 2328-5583 ; ISSN: 2328-5591 (Online) 2017
- [3] Falguni Jindal1, Rishabh Jamar2, Prathamesh Churi "FUTURE AND CHALLENGES OF INTERNET OF THINGS" International Journal of Computer Science & Information Technology (IJCSIT) Vol 10, No 2, April 2018
- [4] N. Sathiyathan, Selvakumar. S, P. Selvaprasanth, A Brief Study on IoT Applications, International Journal of Trend in Scientific Research and Development (IJTSRD), Volume 4 Issue 2, February 2020 Available Online: www.ijtsrd.com e-ISSN: 2456 – 6470
- [5] Muhammad A. Iqbal, Oladiran G.Olaleye & Magdy A. Bayoumi, A Review on Internet of Things (Iot): Security and Privacy Requirements and the Solution Approaches, Global Journal of Computer Science and Technology: E Network, Web & Security, Volume 16 Issue 7 Version 1.0 Year 2016, ISSN: 0975-4350
- [6] Mahmoud Elkhodr, Seyed Shahrestani and Hon Cheung, "Emerging wireless technologies in the internet of things: a comparative study", International Journal of Wireless & Mobile Networks (IJWMN) Vol. 8, No. 5, October 2016
- [7] Ms. Rashmi Dongre, Dr. Meera Deshmukh, "Internet of Things (IOT) and Smart City- Transformation of Cities through IOT" , International Journal of Applied Engineering Research ISSN 0973-4562 Volume 14, Number 7, 2019 (Special Issue)
- [8] Zeinab Kamal Aldein Mohammeda, Elmustafa Sayed Ali Ahmedb, Internet of Things Applications, Challenges and Related Future Technologies, WSN (world scientific news) +67(2) (2017) 126-148 EISSN 2392-2192
- [9] Vandana Sharma1 , Ravi Tiwari, A review paper on "IOT" & It's Smart Applications, International Journal of Science, Engineering and Technology Research (IJSETR), Volume 5, Issue 2, February 2016
- [10] Mourvika Shirode, Monika Adaling, Jyoti Biradar, Trupti Mate, IOT Based Water Quality Monitoring System, International Journal of Scientific Research in Computer Science, Engineering and Information Technology © 2018 IJSRCSEIT | Volume 3 | Issue 1 | ISSN : 2456-3307



- [11] AmathulHadiShakara , Md. TareqHasan, Solutions of common challenges in IoT, IOSR Journal of Computer Engineering (IOSR-JCE) e-ISSN: 2278-0661,p-ISSN: 2278-8727, Volume 19, Issue 5, Ver. V (Sep.- Oct. 2017), PP 57-65
- [12] Vangelis Gazis, Manuel Goertz, Marco Huber, Alessandro Leonardi, Short Paper: IoT: Challenges, Projects, Architectures, 2015 18th International Conference on Intelligence in Next Generation Networks
- [13] Vinay sagar K N, Kusuma S M, Home Automation Using Internet of Things, International Research Journal of Engineering and Technology (IRJET) e-ISSN: 2395-0056 Volume: 02 Issue: 03 | Jan-2015 www.irjet.net p-ISSN: 2395-0072
- [14] Malak Alamri , NZ Jhanjhi, Mamoon Humayun, Blockchain for Internet of Things (IoT) Research Issues Challenges & Future Directions: A Review, IJCSNS International Journal of Computer Science and Network Security, VOL.19 No.5, May 2019
- [15] Cleber M. de Moraes, Djamel Sadok and Judith Kelner “An IoT sensor and scenario survey for data researchers”, Moraes et al. Journal of the Brazilian Computer Society 2019.(Springr)
- [16] Sachin Kumar , Prayag Tiwari and Mikhail Zymbler, “Internet of Things is a revolutionary approach for future technology enhancement: a review” , Kumar et al. Journal of Big Data (2019) 6:111(Springer)
- [17] Dr. J. Jegathesh Amalraj, S. Banumathi, J. Jereena John, “ IOT Sensors And Applications: A Survey” ,International Journal of Scientific & Technology Research , Volume 8, Issue 08 August 2019
- [18] Furqan Alama, Rashid Mehmoodb, Iyad Katiba, Aiiad Albeshria” Analysis of Eight Data Mining Algorithms for Smarter Internet of Things (IoT)” , International Workshop on Data Mining in IoT Systems (DaMIS 2016) Procedia Computer Science 98 ( 2016 ) 437 – 442, Elsevier
- [19] Zozo Hassan, Hesham Arafat Ali, , Mahmoud M. Badawy “Internet of Things (IoT): Definitions, Challenges, and Recent Research Directions “,International Journal of Computer Applications (0975 – 8887) Volume 128 – No.1, October 2015
- [20] Dr. Antonio Carlos Bento ,” IoT: NodeMCU 12e X Arduino Uno, Results of an experimental and comparative survey “,International Journal of Advance Research in Computer Science and Management Studies , Volume 6, Issue 1, January 2018
- [21] P. Ashwini, Pavan. S, Roja Ramani A, “ A Comparative Study of Arduino Uno, NodeMCU in IoT”, 2018 IJSRSET ,Volume 4 ,Issue 7 ISSN: 2395-1990
- [22] K. Swathi, T. Uday Sandeep, A. Roja Ramani, “ Performance Analysis of Microcontrollers Used In Iot Technology, 2018 IJSRSET | Volume 4 | Issue 4 | Print ISSN: 2395-1990
- [23] Dlnya Abdulahad Aziz, “ Webserver Based Smart Monitoring System Using ESP8266 Node MCU Module”, International Journal of Scientific & Engineering Research Volume 9, Issue 6, June-2018 801 ISSN 2229-5518
- [24] Mr. M.Pratap Rajua, Dr. A. Jaya Laxmib ,” IOT based Online Load Forecasting Using machine learning algorithm”, Third International Conference on Computing and Network Communications (CoCoNet’19)
- [25] Lalit Mohan Satapathy,Samir Kumar Bastia, Nihar Mohanty, “Arduino based home automation using Internet of things (IoT)”, International Journal of Pure and Applied Mathematics,Volume 118 No. 17 2018, 769-778.
- [26] Mubashir Ali, Zarsha Nazim, Waqar Azeem, Khadija Javed, Maria Tariq, Muhammad Haroon, Aamir Hussain,” An IoT based Approach for Efficient Home Automation with ThingSpeak”, (IJACSA) International Journal of Advanced Computer Science and Applications, Vol. 11, No. 6, 2020
- [27]Mr.J.Chandramohan,K.Satheeshkumar,P.A.Gopinath, N.Aj ithkumar, S.Ranj ithkumar,” Implementation of Smart Home Automation and Security System Using Arduino and Wi-Fi through Android Application”, International Journal of Engineering Research & Technology (IJERT) ISSN: 2278-0181, Published by, ICONNECT - 2017 Conference Proceedings
- [28] Mr. Nerella Ome, Mr. G. Someswara Rao, “ Internet of Things (IoT) based Sensors to Cloud system using ESP8266 and Arduino Due”, International Journal of Advanced Research in Computer and Communication Engineering ISO 3297:2007 Certified Vol. 5, Issue 10, October 201
- [29] Bento, Antonio Carlos,” IoT + NRF24L01 X NodeMCU12e: An Applied Survey on Data Sending via Radio”, American Journal of Research Jan-Feb 2018
- [30] Dlnya Abdulahad Aziz, “Webserver Based Smart Monitoring System Using ESP8266 Node MCU Module”, International Journal Of Scientific & Engineering Research, Volume 9, Issue 6, June-2018 Issn 2229-5518
- [31] Prathmesh Shelke, Shubham Kulkarni, Swapnil Yelpale3, Omkar Pawar, Ravdeep Singh, Kirti Deshpande, A NodeMCU Based Home Automation System, International Research Journal of Engineering and Technology (IRJET) e-ISSN: 2395-0056 Volume: 05 Issue: 06 | June-2018
- [32] Mohammad miraj shekh1, Asha S. R2, Hariprakash3, Harshitha4,” IoT Based Home Automation using NODE MCU”, IJESC 2018