



Visual Cryptography for Image Security

Shravan Kumar ¹, Ganesh V N ², Suprabha ³, Sooraj Shetty ⁴, M B Sachin ⁵

Dept. of Electronics & Communication Engineering,
Mangalore Institute of Technology & Engineering, Moodabidri, India

Abstract: Cryptography secures the data during the interaction between different systems. The attackers may use the opportunities to attack the data within the database. Therefore, the security of image is of high importance. In this idea, a private image is bifurcated into two shares of images and these images to be displayed when the two share images are available together; photos of sole share cannot reveal the identity of the actual image. To achieve this, Visual Cryptography is used. There are various dimensions on which VCS performance relay, i.e., accuracy, brightness, pixel widening, security, computer complexity, productive sharing is logical or pointless, a kind of private image. This process encrypts a private image into stocks so that it can collect a sufficient number of shares produces a private image. This project uses VC of coloured images in a biometric application.

Keywords: Biometrics; Visual Cryptography; VCS; Private Face Image.

I. INTRODUCTION

In today's fast-moving world, security plays a vital role in everyday life. Today, many digital images are distributed and traded online. It has created an atmosphere where information is easy to share, clone and modify. Security has become an important factor while communicating, this is due to the presence of hackers waiting for an opportunity to gain access to private data. The computer performs cryptographic functions and from this point, the process becomes fast and secure. Biometrics is the measurement of characteristics that can be used to identify an individual. There are a variety of applications that need to be identified such as computerized control login, secured electronic banking, border crossing, airport, mobile phones etc. The biometric system works on retrieving raw biometric data from the user, extracting the set of features from the data and comparing it with the templates stored on the database to verify the desired identity. There are many techniques in biometric that are available such as fingerprints, retina, face, iris, palmprint, hand vein, voice, signature, keystroke, hand geometry and facial thermogram etc. The template data is created during enrolment and is mostly stored along with the original data. This increased the need for confidentiality in the article by adequately protecting the content of the website. Hence, "Visual Cryptography" is used. In VC, shared images are designed to contain sensible cover images, thus integrate VC and biometric security techniques. At first, this method was used for white and black images but later stated for coloured images as well.

II. METHODOLOGY

Biometrics can be used to authenticate person's identity. The two stages of biometric system are registration and recognition. The first step involves extracting the feature and pre-processing. The features are stored as templates on the database. Therefore, Visual Cryptography is used. It is a private sharing system where we can recover the privacy of any k-share image which are piled together. The entire image contains Red, Blue and Green of 8-bit colours each.

A. Working

This proposed method is divided into 3 parts, namely Image Encryption, Image Decryption and Face Matching. There are many ways we can continue this process. VC can be categorized on the basis of embedded images and logical performance during resharing. Based on the included images can be categorized as binary images and Grayscale scales and based on logical operation OR based and XOR based. Here Halftoning "Floyd Steinberg Dithering Algorithm" for image capture. The dithering algorithm is used instead of image stabilization. The potency of the actual image is maintained by this method. The Fig. 2.1 shows the flow diagram of the work.

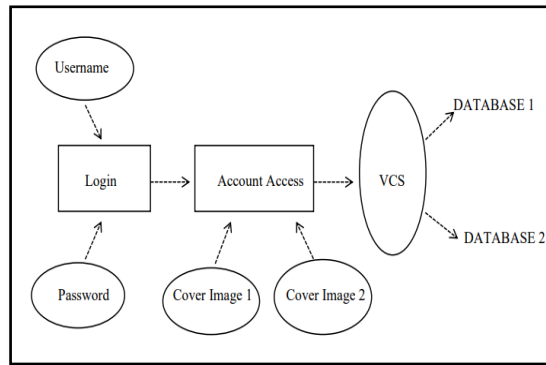

Fig. 2.1: Data Flow diagram for the Proposed System

B. Encryption

Every image consists of 3 shares, RGB, hence each image is divided into 3 shares. This is known as Sieving. These RGB shares are divided into 2 more shares each i.e., R1, G1, B1, R2, G2, B2 a total of 6 small shares. This is called Division. Further these 6 shares are shuffled using XOR based VC. This is called Shuffling. Then a random share is generated to form 2 different shares and saved, these are then shared to different users or database. This is called Combining as shown in Fig. 2.2 below. The encryption process is done through Floyd-Steinberg algorithm.

C. Decryption

The 2 randomly generated images are chosen to obtain the decrypted image as shown in Fig. 2.3 below. Next process is face matching, where it matches the original image with the decrypted image and checks for the similarity.

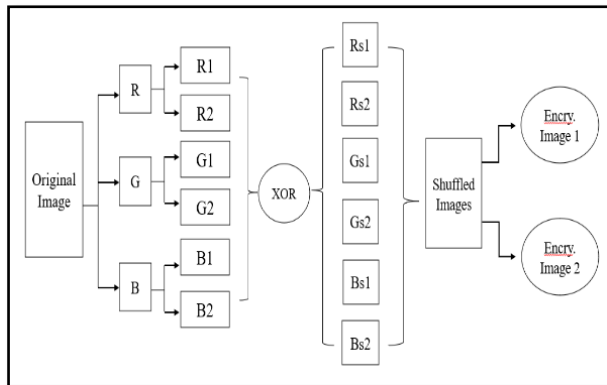

Fig. 2.2: Encryption Method

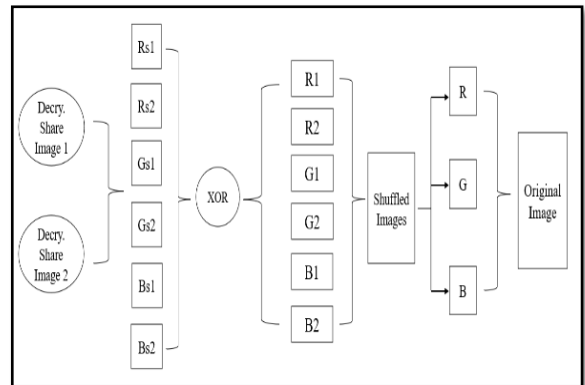

Fig.2.3: Decryption Method

D. Face Matching

After the encryption and decryption process, verification of the image is necessary. This is done through RANSAC method. It is used to detect the face edges which is helpful for the detection and face verification process.

III. RESULTS

A. Encryption Process

Source Image: image.png
Source image used:





Number of shares generated: 6
Image Division:



Encryption:

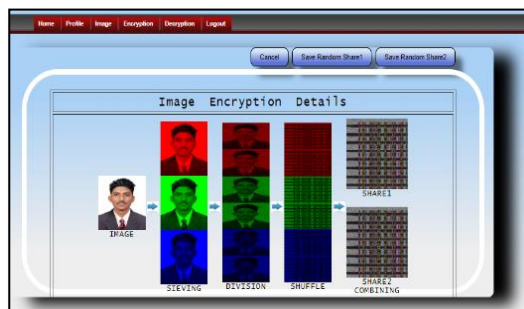

B. Decryption Process

Number of shares used: 6
Reconstructed (Decrypted) Image:

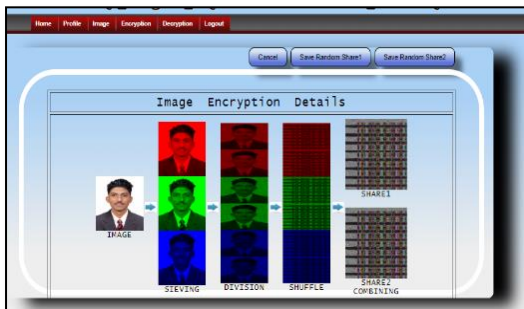

C. Face Matching



IV. CONCLUSION

VC is basically an encryption method which has a merit of decrypting encrypted images rather than cryptographic computations. The significance of VCS in enhancing in the security and integrity of secret information has also been considered. The proposed system is done with Floyd Steinberg and RANSAC algorithm.



ACKNOWLEDGMENT

The authors are thankful to **Mr. Ganesh V N**, our internal guide, Mangalore Institute of Technology & Engineering for his constant support and guidance. Thank you for all the professors and friends for helping us.

REFERENCES

- [1]. Arun Ross, Asem Othman, "Visual Cryptography for Biometric Privacy", IEEE Transactions on Information Forensics and Security, VOL.6 No.1, MARCH 2011.
- [2]. Naor, M. and Shamir, A, "Visual Cryptography" EUROCRYPT 1994. Lecture Notes in Computer Science, Vol. 950. Springer, Berlin, Heidelberg (1999).
- [3]. Shefali Arora & M.P.S Bhatia, "Challenges and opportunities in biometric security: A survey", Information Security Journal: A Global Perspective (2021).
- [4]. Jeng - Shyang Pan, Tao Liu, Hong-Mei Yang, Bin Yan, Shu-Chuan Chu, Tongtong Zhu, "Visual cryptography scheme for secret colour images with colour QR codes", Elsevier November 2021.
- [5]. Jyoti Tripathi, Anu Saini, Kishan, Nikhil, Shazad, "Enhanced Visual Cryptography: An Augmented Model for Image Security", (ICCIDS 2019), Published by Elsevier B.V.
- [6]. M. Karolin and T. Meyyappan, "Secret Multiple Share Creation with Color Images using Visual Cryptography", April 4-6, 2019, India, IEEE.
- [7]. M. Karolin, T. Meyyappan, "Image Encryption and Decryption using RSA Algorithm with Share Creation Techniques", ISSN: 2249 – 8958, Volume-9 Issue-2, December 2019.
- [8]. P. Punithavathi & S. Geetha (2017), "Visual cryptography: A brief survey", Information Security Journal: A Global Perspective, 26:6, 305-317 (Taylor & Francis).
- [9]. M. Karolin, Dr. T. Meyyappan, "RGB Based Secret Sharing Scheme in Color Visual Cryptography", Vol. 4, Issue 7, July 2015, DOI: 10.17148/IJARCCE.2015.4734.
- [10]. Apurva A. Mohod, Prof. Komal B. Bijwe, An Image Database Security Using Multilayer Multi Share Visual Cryptography: A Review, ISSN 2319 -4847, Volume 3, Issue 10, October 2014.
- [11]. Ms Neha Khatri – Valmik, Prof. V. K Kshirsagar, "Blowfish Algorithm", ISSN: 2278-8727 Volume 16, Issue 2, Ver. X (Mar-Apr. 2014), PP 80-83.
- [12]. Atul Sureshpant Akotkar, Chaitali Choudhary, "Secure of Face Authentication using Visual Cryptography", International Journal of Innovative Science and Modern Engineering (IJISME) ISSN: 2319-6386, Volume-2, Issue-5, April 2014.
- [13]. Shubhangi Rajanwar1, Shirish Kumbar2, Akshay Jadhav, "Visual Cryptography for Biometric Privacy", International Journal of Science and Research (IJSR), ISSN: 2319-7064, Volume 3 Issue 12, December 2014.
- [14]. N. Askari, H.M. Heys, and C.R. Moloney, "An Extended Visual Cryptography Scheme Without Pixel Expansion for Halftone Images" (2010).
- [15]. Bhagyashri P. Kandalkar, Gopal D. Dalavi, "Development of Visual Cryptography Technique for Authentication using Facial Images", IJSR, ISSN: 2319-7064, Volume 4 Issue 12, Dec 2016.
- [16]. Dr. D. Devakumari MCA., M.Phil., PhD.1, K. Geetha, "A Survey of Visual Cryptographic Method for Secure Data Transmission", ISO 3297:2007 Certified Vol. 6, Issue 6, June 2017.
- [17]. Tiwari, Meher Gayatri Devi; Kakelli, Anil Kumar. "Secure Online Voting System using Visual Cryptography", Walailak Journal of Science & Technology Vol 18, Issue 15, January 2021.
- [18]. Mr. Ravi Kumar, Ms. Namrata Singh, "A survey based on Enhanced the Security of Image using the combined techniques of steganography and cryptography", International Conference on Innovative Computing and Communication (ICICC 2020).
- [19]. Santhi, B K.S. Ravichandran, A.P. Arun and L. Chakkrapani, "A Novel Cryptographic Key Generation Method Using Image Features", Research Journal of Information Technology 4(2):88-92, 2012.
- [20]. Anantha Kumar Kondra, Smt. U. V. RatnaKumari, "An Improved (8, 8) Color Visual Cryptography Scheme Using Floyd Error Diffusion", in International Journal of Engineering Research and Applications, Vol. 2, Issue 5, September-October 2012, pp.1090.
- [21]. L. N. Pandey and Neeraj Shukla, "Visual Cryptography Schemes using Compressed Random Shares", in International Journal of Advanced Research in Computer Science and Management Studies, Volume 1, Issue 4, September 2013, pp:62 – 66.
- [22]. M. Karolin, Dr. T. Meyyappan.SM. Thamarai, "Image encryption and decryption of color images using visual cryptography" International Journal of Pure and Applied Mathematics, Volume. 118, No. 8, 2018, 277-281.
- [23]. Sozan Abdulla, (2010) "New Visual Cryptography Algorithm for Colored Image" Journal of Computing.
- [24]. R. Floyd and L. Steinberg, "An adaptive algorithm for spatial greyscale," SPIE Milestone Series 154, pp. 281–283, 1999.



- [25]. Ateniese, G., Blundo, C., Santis, A., & Stinson, D. (2001), "Extended Capabilities for Visual Cryptography. Theoretical Computer Science, doi:10.1016/S0304-3975(99)00127-9.
- [26]. Manika Sharma & RekhaSaraswat, (2013) "Secure Visual Cryptography Technique for Color Images Using RSA Algorithm", International Journal of Engineering and Innovative Technology (IJEIT) Volume, 2.
- [27]. Ram Gopal Sharma, Priti Dimri, Hitendra Garg, "Visual Cryptographic Techniques for secret image sharing: A Review", Vol 27, 2019 (Taylor & Francis).
- [28]. Hou, Y. C., & Tu, S. F, "A visual cryptographic technique for chromatic images using multi-pixel encoding method", Journal of Research and Practice in Information Technology, 2005, 37(2), 179–192.
- [29]. Hou, Y, "Visual cryptography for color images. Pattern Recognition", 2003, 36(7), 1619–1629. doi:10.1016/S0031-3203(02) 00258-3
- [30]. Miss. Nuzhat Ansari, Prof. Rahila Shaikh, "A Keyless Approach for RDH in Encrypted Images using Visual Cryptography", ICISP2015, 11-12 December 2015, Nagpur, INDIA.
- [31]. Konstantinos G. Derpanis, "Overview of the RANSAC Algorithm", May 13, 2010.
- [32]. Anantha Kumar Kondra, Smt. U. V. RatnaKumari, "An Improved (8, 8) Color Visual Cryptography Scheme Using Floyd Error Diffusion", in International Journal of Engineering Research and Applications, Vol. 2, Issue 5, September-October 2012, pp.1090.
- [33]. Dyala R. Ibrahim, Je Sen The, Rosni Abdullah, "An Overview of Visual Cryptography Techniques", January 2021.