



Solar Energy-based Mobile Charger Using Inductive Coupling Transmission

Akshitha M S¹, Kalaiah J B²

Dept. of ECE, SJCIT, Chikkaballapur, India^{1,2}

Abstract — Mobile phones are used by citizens of nearly all nations as a crucial communication tool. As technology advances, there are now more mobiles than there are mobile phone users. sophisticated, incredibly user-friendly, and inexpensive device. The average battery life of a mobile phone is less than 10 hours, therefore people cannot use them to travel great distances. Therefore, we created a wireless solar mobile charger that harnesses solar power to provide enough electricity to recharge smartphones. The purpose of employing a wireless solar mobile charger is to create electricity from a renewable energy source at no cost. It will also provide a better alternative for people who travel great distances with their mobile devices.

Keywords—Solar panel, battery, inductive coupling, Arduino nano, Esp8266, LCD, relay.

I. INTRODUCTION

The advancement of technology has enhanced our People still struggle with the problem of having to put their cell phone's battery into a wall charger even though mobile phones have gotten smaller and simpler to use [1]. We can always have our mobile phone chargers with us, but we can't always count on having access to electricity [9]. To circumvent this problem, the majority of individuals carry supplementary batteries or power banks. In the event of a power outage, we are still unable to use backup batteries like power banks to recharge our mobile phones. So, to circumvent this problem, we developed a solar-powered mobile charger. In particular, in outdoor or off-grid settings, the creation of a solar energy-based mobile charger using an inductive coupling gearbox can offer a workable and sustainable alternative for charging mobile devices. Utilizing a wireless solar mobile charger is mostly done so that we can create electricity for nothing. When there is sunlight present, the mobile phone will charge whenever and wherever it is. We can deploy this device in remote locations where power outages are a problem.

II. RELATED WORK

Sl No	Paper	Author's name	Journal name	Publish year
1.	Design of Solar power wireless Charger for Smartphones	Hari Mohan Rai, Piyush Sisodiya	IRJET	2016
2.	Solar wireless power transfer using inductive coupling for a mobile phone charger	M.Fareq, M.Fitra	IEEE	2014
3.	Wireless power transfer by incorporation of solar energy	Anand.M Yogesh Kannan	IJRDET	2014
4.	Wireless power transmission for charging Mobile phones.	Aakib.J, Sayyad N.P Sarvade	IJETT	2014

Table 1: Literature Survey



Hari Mohan Rai and Piyush Sisodiya are coming up with the concept, of There is no need for a communication line to be attached to the supply facility to charge a smartphone, for a solar-powered wireless charger. Within a short distance, the mobile phone can be wirelessly charged. No need to hang around the phone. Even we can use no energy to charge our phones. The device is user-friendly and reasonably priced. [8]

M. Freq M. Fitrq (2014) in this paper, he said, working on the inductive coupling. It is based on the idea of reciprocal induction. The Wireless power transfer occurs between the transmitter and the receiver. Transceivers for power transmission through an inductive coil and rectifiers for converting AC to DC voltage make up the three components of the wireless inductive power transfer system. [5]

Anand M. and Yogesh Kannan in the document in which they publish the solar panel review. A tiny solar cell makes up the solar panel, which transforms solar energy into electrical energy. [6]

III . PROPOSED WORK

1) BLOCK DIAGRAM

This is a block diagram illustrating the project's suggested model. Its components include an Arduino Nano controller, a relay driver, an ESP8266 WiFi module, a power supply for buzzers and LEDs, and an LCD.

The voltage regulator on which the Arduino Nano runs receives a fixed 5 V voltage from the power source. The Arduino uses programming to regulate the voltage of the wireless power source, the batteries, and the solar panel. The LCD is used to display the wirelessly transferred voltage, battery voltage, and solar voltage.

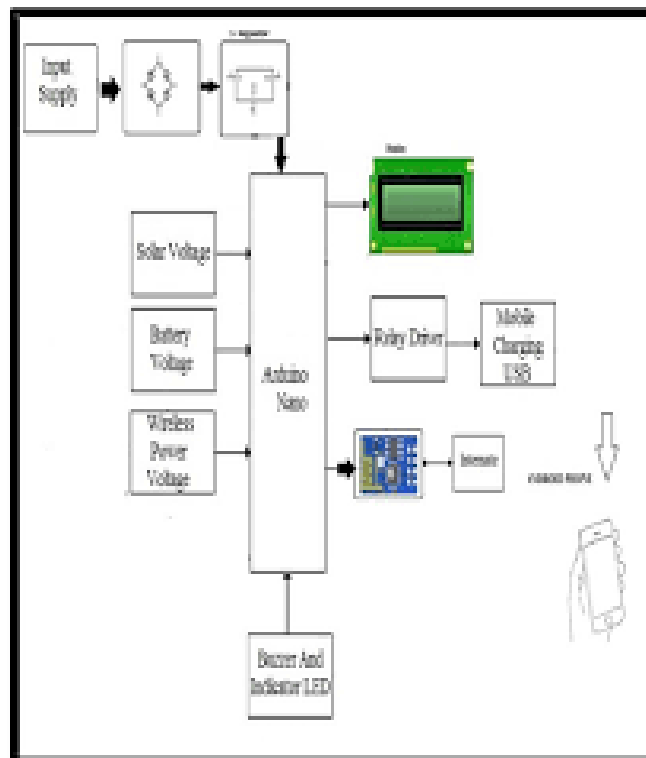

Figure 1. Block Diagram of the Proposed Model

A Wi-Fi module is called Esp8266. It uses 3.3V, which is supplied by Arduino, to work. The Arduino transmitter is attached to its transmitter pin.

With the aid of the Blynk app, our smartphones will be controlled by it. Both a hotspot and Wi-Fi connection will be established. To indicate ideal functioning conditions, the buzzer and LED are utilized. The buzzer and led will glow when Arduino is in good working order. The relay is utilized for switching. The mobile device is linked through USB.



a) Solar Panel

A solar panel is a device that converts sunlight into electricity. It is composed of many photovoltaic (PV) cells, which are made of semiconductor materials such as silicon. When sunlight hits the PV cells, it excites the electrons and creates a flow of electricity. The amount of electricity produced depends on the intensity of sunlight and the size of the solar panel. Solar panels are used in a variety of applications, including residential and commercial power systems, portable chargers, and outdoor lighting. They are becoming increasingly popular due to their renewable and sustainable nature, as well as the potential cost savings associated with using solar energy. Advances in technology have also made solar panels more efficient and cost-effective, making them a viable option for a wide range of applications.

Photovoltaic Cell

A photovoltaic (PV) cell, also known as a solar cell, is a device that converts light energy into electrical energy. When photons from sunlight strike the PV cell, they can cause electrons to be excited, creating a flow of electrons and holes that generates an electrical current. A PV cell is typically made of semiconductor material, such as silicon, and is usually only a few micrometers thick. Multiple PV cells can be connected to form a PV module, and multiple modules can be connected in series or parallel to form a PV array. PV cells are commonly used in solar panels, which can be installed on rooftops, in fields, or other areas with access to sunlight. The electrical energy generated by the PV cells can be used to power homes, businesses, or other devices, or it can be stored in batteries for later use.

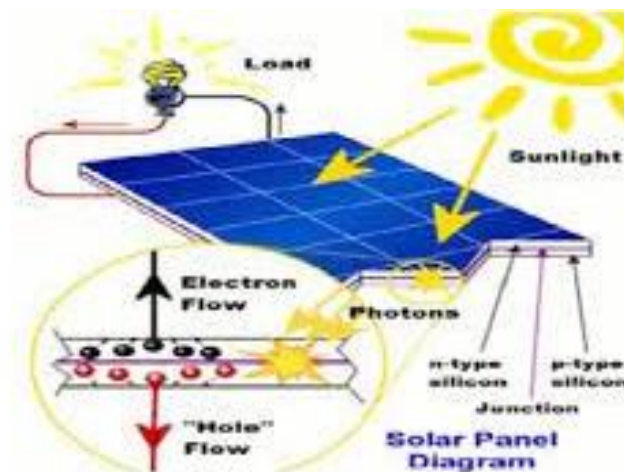

Figure 1.1. Solar Panel. [2]

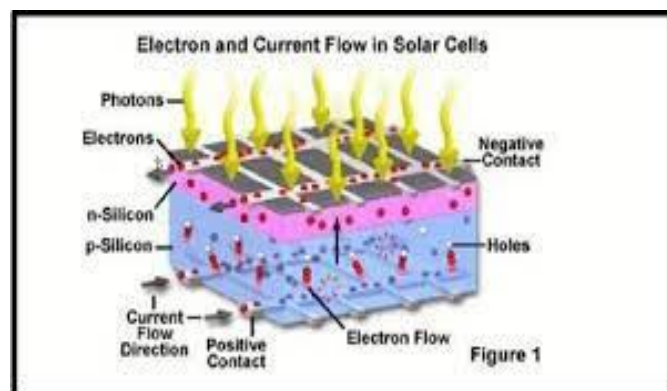

Figure 1.2 Electron And Current Flow In Solar Cells.[3]

b) Battery:

An electrochemical device known as a battery holds chemical energy that can be transformed into electrical energy. Batteries come in a variety of forms, such as lead-acid, nickel-cadmium, lithium-ion, and lithium-polymer. Due to their



high energy density, lightweight, and low self-discharge rates, lithium-ion or lithium-polymer batteries are frequently utilized in solar mobile chargers. These batteries are rechargeable and can store solar panel energy for use in future mobile device charging. The quantity of energy that can be stored and delivered to the mobile device is determined by the battery's capacity and voltage, which are crucial considerations when constructing a solar mobile charger.



Figure 1.3. Battery.

C) Inductive Coupling

The system's wireless power transfer is accomplished using inductive coupling. Mutual inductance serves as the foundation for this inductive coupling principle.[4] Faraday's law of electromagnetic induction is used to transfer the most energy possible through the magnetic field. Inductive coupling functions similarly to how a resonant transformer does.

AC voltage is required for the inductive coupling mechanism to function. It consists of two coils: the primary coil is located on the transmitter side, while the secondary coil is located on the receiving side. The inductance of the two coils is used to calculate the degree of inductive coupling between them. The voltage will produce up to 5V at the inductive coupling's output.



Figure 1.4. Inductive Coupling [4]

1) Control Unit

A device or group of devices known as the control unit supervises the operation of the solar mobile charger system. An Arduino Nano microcontroller serves as the control element in this scenario and is in charge of managing and observing the various system components. It analyses the input signals from the battery, solar panel, and inductive coupling module and then adjusts the charging process as necessary. The ESP8266 WiFi module and the control unit also exchange data, allowing for wireless system control and monitoring. To show the status and progression of the charging process, it controls the LCD that is linked to it. To ensure the battery operates safely, the control unit also oversees the circuitry for overcharge and over-discharge prevention.



Figure 1.5: Control Unit

➤ **Arduino Nano**

This project makes use of the Arduino Nano. It functions as a controller. It features digital pins, reset pins, power pins, and 30 analog pins. It uses a 5V supply to work. It is the same size as a mall and performs the same functions as an Arduino UNO. This Arduino, which is connected to the Arduino Nano's pins D2-D7, controls the LCD.

Based on the ATmega328P microcontroller, the Arduino Nano is a diminutive and portable microcontroller board. It performs similarly to the Arduino Uno but is smaller in size. A total of 30 input/output (I/O) pins are present on the board, including 14 digital, 8 analog, and 6 pulse-width modulation (PWM) pins. Additionally, it contains power pins and a reset button.

➤ **Esp8266**

A cheap Wi-Fi module called the ESP8266 enables microcontrollers to connect to wireless networks. It is a single-chip device with a microprocessor that can establish a wireless network connection. It can be utilized in many different applications, including wireless sensor networks, IoT devices, and home automation. It can support many connections at once and has a built-in TCP/IP stack. It can be written using the Arduino IDE and can run in either client or server mode. It has Wi-Fi connectivity and may be used to remotely operate and keep an eye on various devices.

➤ **Relay**

An electromagnet drives an electrical switch known as a relay. It is made up of contacts and a coil. The contacts are drawn together by the magnetic field produced when the coil is energized, allowing electricity to pass through the switch. Relays are frequently used to manage low-power signals from switches or microcontrollers to high-power devices like motors or lights. They can also be used to switch between numerous circuits or isolate various circuits. Depending on how many contacts and switches they contain, relays can be configured in a variety of ways, including single-pole single-throw (SPST), single-pole double-throw (SPDT), double-pole double-throw (DPDT), and others.

➤ **LCD Display**

Images are displayed using liquid crystals in LCD (Liquid Crystal Display) display technology. In this technique, the liquid crystal layer is subjected to an electric field that alters the orientation of the crystals, either allowing light to pass through or obstructing it. A character LCD that can display alphanumeric characters and symbols was used in the solar mobile charger project. It is managed by passing commands through the data pins to the Arduino Nano controller, which is attached to it. The user can view the charging status and other pertinent data on the display.

IV. TECHNOLOGIES

1) **Maximum Power Point Tracking (MPPT) :**

The use of Maximum Power Point Tracking (MPPT) technology helps solar panels produce as much power as possible. It is based on continuous monitoring and modifying the solar panel's operating point to make sure it is working at its peak power level. To match the solar panel's voltage and current output to the ideal load for the existing environmental circumstances, such as the strength and angle of the sun's rays, MPPT technology uses an electronic controller. As a result, the solar panel system produces more power and is more efficient. To maintain optimal performance and efficiency, MPPT technology is frequently utilized in solar-powered equipment and systems, including solar mobile chargers.



2) **Wireless charging:**

Mobile devices can receive wireless power transfers using inductive coupling, a wireless charging technology. Two coils, a transmitter coil, and a receiver coil, are used in this technology. An electrical current is induced in the reception coil by the pulsating magnetic field created by the transmitter coil. The wireless battery of the mobile device is then charged using this current. Electric toothbrushes, smartphones, and wearable gadgets all make extensive use of inductive coupling technology.

3) **Overcharge and over-discharge protection:**

The battery in the solar mobile charger system is protected from overcharge and over-discharge using technology. Battery damage can result from overcharging or over-discharging, which can also provide a safety risk. Protection circuits are therefore employed to avoid these circumstances. A voltage regulator is frequently used in the overcharging protection circuit to ensure that the voltage across the battery does not go over a predetermined threshold. Similar to the over-discharging protection circuit, a voltage regulator is frequently used to make sure the voltage across the battery does not go too low. The safe and dependable operation of the solar mobile charger system depends on these protective circuits.

4) **Lithium-ion or Lithium-polymer battery:**

Solar mobile chargers utilize lithium-ion and lithium-polymer battery technology for effective energy storage. High energy density, low self-discharge rates, and long cycle life are all characteristics of these battery technologies. They are useful for portable applications like solar mobile chargers since they are relatively light and compact compared to other battery technologies. They can be quickly recharged using the solar panel because they are also rechargeable and have a fast charging rate.

V RESULT

The output voltage increases along with the increase of coil turns. utilizing wireless power transmission magnetic coupling 20 turn coils were employed on both the transmitter and receiving sides.

This coil, which has 20 turns, has a 4.5 cm diameter and can handle 1.3 amps of electricity. A voltage of about 5 volts will be applied across the inductive coupling. The following table lists the results that were obtained:

Sl.No	Value of Ranges	DC Output Voltage
1.	00	00
2.	0.5	0.10
3.	1.0	0.50
4.	1.5	0.89
5.	2.0	1.0
6.	2.5	1.10
7.	3.0	1.21
8.	3.5	2.20
9.	4.0	3.15
10.	4.5	3.50
11.	5.0	3.90

Table 2: Result



VI APPLICATIONS

1. Camping and trekking: While camping or hiking, the solar mobile charger can be used to charge mobile gadgets like smartphones, tablets, and GPS units.
2. Outdoor events: The charger can be used to supply electricity for outdoor events including sporting competitions, concerts, and festivals.
3. Remote areas: The charger can be utilized in far-off places with limited access to electricity.
4. Marine and boating: The charger can be used to power mobile devices when in marine and boating environments.
5. Situations where there is no electrical power or there is a power outage: The charger can be utilized in these circumstances.

VII CONCLUSION

In conclusion, the solar mobile charger project offers a long-term and environmentally responsible answer to the issue of charging mobile devices in places with poor access to energy. The efficient power output from the solar panel is ensured by the employment of MPPT technology and solar panel technology for power generation. Energy storage is made safe and dependable by using a lithium-ion or lithium-polymer battery together with overcharge and over-discharge prevention technology. The charger is user-friendly and economical with energy thanks to the incorporation of wireless charging technology, LED status indication technology, and low-power consumption technology. The charger operates smoothly and precisely thanks to the employment of the relay and LCD technologies, as well as the control and communication technologies Arduino Nano and ESP8266.

VIII FUTURE SCOPE

There is a lot of room for advancement and improvement in the solar mobile charger project in the future. Using more sophisticated MPPT algorithms to better optimize the power output of the solar panel is one potential area for improvement. To maximize energy storage capacity while minimizing the size and weight of the charger, it may be possible to employ more efficient and smaller batteries, such as solid-state batteries. Additionally, by boosting charging effectiveness and range, the wireless charging technology used in this project can be made even better. A wider range of mobile devices could potentially be charged by incorporating more sophisticated wireless charging standards, like Qi.

IX ACKNOWLEDGMENT

We would like to take this opportunity to thank our mentor, professor **A.V. Sutar** of the Department of Electronics and Telecommunication, from the bottom of our hearts for his Throughout this project, excellent oversight, monitoring, and ongoing encouragement were provided. Throughout our journey, he has given us courage.

REFERENCES

- [1] A. R. Al-Ali and M. AlShamasin, "Design of a Solar-Powered Portable Mobile Charger with Power Bank Functionality," 2019 International Conference on Computer and Applications (ICCA), Sharjah, United Arab Emirates, 2019, pp. 1-5.
- [2] A. Khan, A. Muhammad, A. Shahzad and S. A. Khan, "Design and development of solar mobile charger," 2017 IEEE 5th International Conference on Future Internet of Things and Cloud (FiCloud), Prague, 2017, pp. 98-103.
- [3] K. S. Reddy and V. Rajinikanth, "Design and Implementation of Solar Power Based Mobile Charger," International Journal of Advanced Research in Electrical, Electronics and Instrumentation Engineering, vol. 4, no. 4, pp. 3154-3158, 2015.
- [4] H. Lee and Y. Lee, "Design and Implementation of Solar Powered Portable Mobile Charger," 2017 International Conference on Information and Communication Technology Convergence (ICTC), Jeju, South Korea, 2017, pp. 1445
- [5] D. X. Liu, H. Z. Xu, X. Y. Chen, and D. D. Chen, "Design of solar-powered mobile phone charger," 2015 International Conference on Renewable Energy Research and Applications (ICRERA), Palermo, Italy, 2015, pp. 678-681.
- [6] R. K. Agarwal and S. K. Jain, "Solar powered mobile charger," 2014 International Conference on Electronics and Communication Systems (ICECS), Coimbatore, 2014, pp. 1-4.
- [7] A. E. A. Al-Ahmadi, S. S. Al-Rashdi, and A. A. Al-Hashmi, "Design and Implementation of a Solar Powered Mobile Charger," International Journal of Engineering and Technology, vol. 6, no. 5, pp. 353-358, 2014.
- [8] Y. H. Tung and C. H. Chang, "A Solar Mobile Phone Charger with Maximum Power Point Tracking," 2009 International Conference on Sustainable Power Generation and Supply, Nanjing, 2009, pp. 1-5.



- [9] International Journal of Advance Engineering and Research Development Emerging Trends and Innovations in Electronics and Communication Engineering- ETIECE-2017 Volume 5, Special Issue 01, Jan.-2018
- [10] Anand.M, Yogesh Kannan, "Wireless Power Transfer By Incorporation Of Solar Energy", IJRDET, Volume 3, Issue 2, August 2014
- [11] International Journal of Innovative Research in Computer Science & Technology (IJIRCST) ISSN: 2347-5552, Volume-2, Issue -4, July-2014
- [12] A. Vijay Kumar, P.Niklesh, T. Naveen / International Journal of Engineering Research and Applications (IJERA) ISSN: 2248-9622 Vol. , Issue 4, pp. 1506-1510
- [13] International Journal of Scientific & Engineering Research, Volume 5, Issue 10, October-2014 125 ISSN 2229-5518
- [14] D. R. Myers and J. D. McAlpine, "A design methodology for solar-powered wireless charging systems for mobile devices," IEEE Journal of Emerging and Selected Topics in Power Electronics, vol. 4, no. 1, pp. 126-136, 2016
- [15] E. Koutroulis, K. Kalaitzakis, and N.C. Voulgaris "Maximum Power Point Tracking Techniques for Photovoltaic Systems" IEEE Transactions on Power Electronics, vol. 31, no. 6, pp. 4315-4324, 2016.
- [16] J. D. McAlpine, D. R. Myers, and J. R. Wilcox, "Analysis and design of a solar-powered wireless charging system for mobile devices," IEEE Transactions on Power Electronics, vol. 31, no. 6, pp. 4315-4324, 2016.
- [17]] N. H. Islam and M. M. Islam, "Design and implementation of a solar-powered mobile phone charger with overcharge protection," 2016 International Conference on Electrical Engineering and Information Communication Technology (ICEEICT), Dhaka, Bangladesh, 2016, pp. 1-5, doi: 10.1109/ICEEICT.2016.7749134
- [18] M. F. Alam, M. N. A. Khan, M. M. H. Bhuiyan, and M. M. Haque, "Design and implementation of a solar-powered mobile phone charger with battery backup," 2017 4th International Conference on Electrical Engineering and Information & Communication Technology (ICEEICT), Dhaka, Bangladesh, 2017, pp. 1-5, doi: 10.1109/ICEEICT.2017.793
- [19] D. S. Sera, T. Senjyu, and A. Yona, "Development of a solar-powered wireless charger for mobile phones," IEEE Transactions on Consumer Electronics, vol. 58, no. 4, pp. 1294-1300, 2016
- [20] T. Markvart and L. Castañer, Solar Cells: Materials, Manufacture and Operation, Academic Press, 2019.