



“Electrical Fault Detection in Overhead Transmission Line”

Gaurav Jichkar¹, Rahul Mohurle², Vikas Kalambhe³

Guru Nanak Institute of Engineering and Technology Kalmeshwar road, Dahegaon, Nagpur.¹⁻³

Abstract: Transmission lines play a crucial role in the power system by transmitting a significant amount of electric power from the source area to the distribution network. With the exponential growth in power demand, minimizing power losses has become a paramount concern. These losses encompass transmission losses, physical losses, and various technical losses. Additionally, reactive power and voltage deviations pose significant challenges in long-range transmission lines. Fault analysis is pivotal in power system engineering to swiftly clear faults and restore the power system with minimal interruption. However, detecting faults in transmission lines remains a challenging task, necessitating research to enhance system reliability. This paper provides a comprehensive review of transmission line fault detection methods.

Keywords: transmission lines, power system, fault detection, power losses, reliability, fault analysis

I. INTRODUCTION

The topic for the project has been selected as the “**Electrical Fault Detection In Transmission Line**”. It is a totally a new concept, which is not found in any literature. With the more improvement and technical developments, this concept can be put in the market.

The Electrical Fault Detection In Transmission Line system is very convenient system for that consumers. Regarding the distribution system, transmission lines perform the most important part that is to transfer electric power from the generating station to load centres. Since the development of the distribution and transmission system, power system engineers have been an object for locating and detecting faults. As long as the fault detected in short duration, it provides a good service for protecting the apparatus as well as an open way for disconnecting the part where this incident happened at fault, and with the help of this, it gives safe way to the system from any damages. So it is needed to detect the fault otherwise due to fault it causes any disturbance which further tough time to the interconnected system that based on limitations.

The structure of the transmission line constructed to investigate the location of the fault and can give separation only the part where the fault occurs. Stimulating method help in identify and isolate the fault in short period. Suppose when more than two conductors develop contact each other or with the contact take place on the ground to 3 phase systems that are considered at fault which could be a balanced fault or unbalanced fault. Due to these faults stresses are produced in power system equipment that could damage the power system components. So to avoid these harms and to make power quality better, it is essential to know the reasons of fault as well as the location of the transmission lines and solve it properly.

II. PROJECT OBJECTIVE

1. The principle objective of a transmission system is to provide multiple transmission line paths between each generator and each load, so that no generation or load is lost if a transmission line trips.

2. The detection and location of power transmission faults are important for the protection and maintenance of the power system. Many error and location detection methods are related to the voltage values provided by current and voltage transformers.

- fault recognition.
- fault detection.
- improve efficiency.
- to maintain system stability.



III. LITERATURE REVIEW

Transmission Line Fault Detection is a crucial aspect of the electrical power system that helps to ensure the stability and reliability of the power supply by detecting and isolating faults in the transmission line. In recent years, many researchers have focused on developing advanced electrical components and techniques for transmission line fault detection.

In this literature survey, we will review some of the recent research works in this field. Effective positioning of the relay medium in the network will detect any interruption in the power system. The key issue in the transmission system is usually fault detection.

If the fault happens during the power swing, then the fault diagnosis is a tedious one. Early detection of faults is important to ensure the performance of the distributed system. Although there are many solutions for fault detection, it is still a challenge to manage the complexity and uncertainty of system observations to make an accurate detection.

For a reliable and high speed protective relay followed by digital distance safety, fault classification is more important. It is a summary of a brief introduction of transmission line faults and a review of the scope of various old approaches in this area. In this report, we present a review study on the detection of faults using machine learning techniques.

IV. BASIC BLOCK DIAGRAM

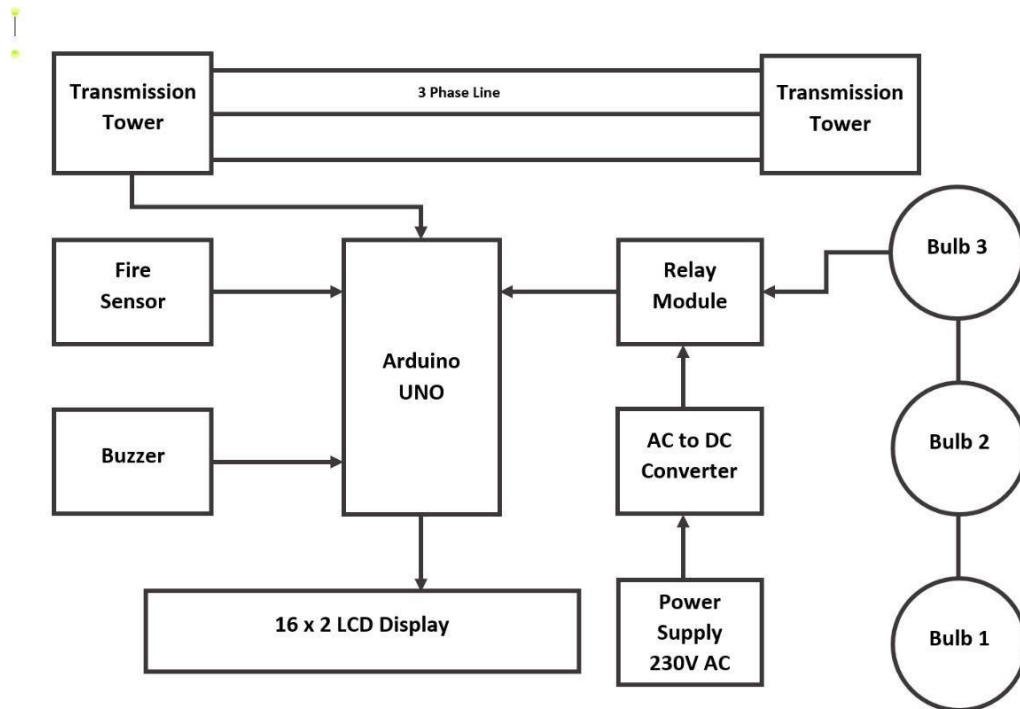

V. COMPONENTS

Arduino

The Arduino Uno is a popular microcontroller board widely used in hobbyist projects and prototyping. It features an ATmega328P microcontroller, offering 14 digital input/output pins, 6 analog inputs, a USB connection for programming and power, a 16 MHz crystal oscillator, a powerjack, an ICSP header, and a reset button.

With its easy-to-use interface and open-source nature, it facilitates the development of various electronic projects, from simple LED blinking to complex robotics. Its versatility, low cost, and large community support make it an ideal choice for beginners and experienced makers alike in exploring electronics and programming.

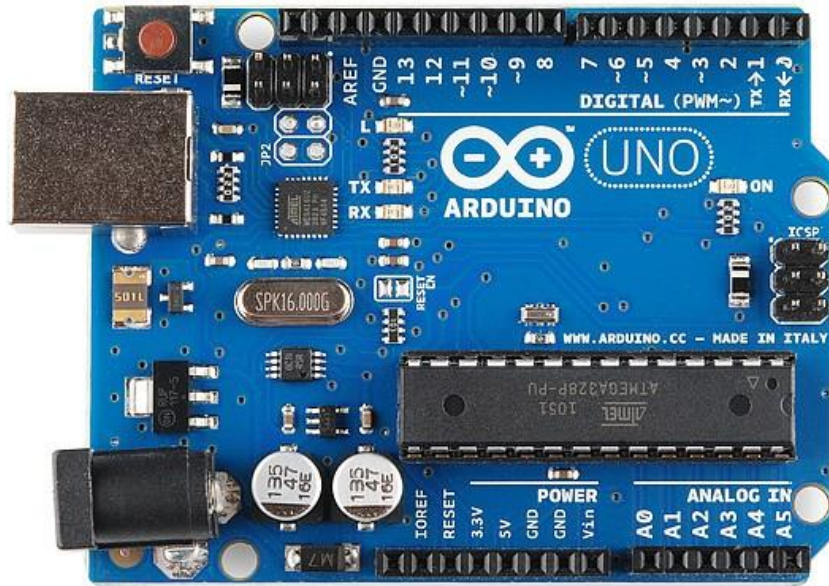

Buzzer

An audio signaling device like a beeper or buzzer may be electromechanical or piezoelectric or mechanical type. The main function of this is to convert the signal from audio to sound.

Generally, it is powered through DC voltage and used in timers, alarm devices, printers, alarms, computers, etc. Based on the various designs, it can generate different sounds like alarm, music, bell & siren.



Relay Module

A relay module is an electromechanical device used to control high-power electrical circuits with low-power signals. It consists of a coil, an armature, and one or more sets of contacts.

When a small electrical current flows through the coil, it generates a magnetic field, which attracts the armature, causing it to move. This movement either opens or closes the contacts, depending on the design of the relay.

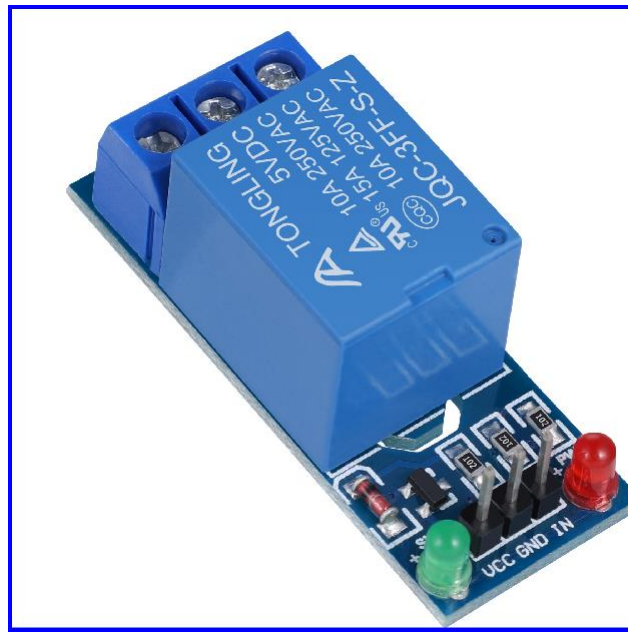

Fire Sensor module

fire sensor module is a device designed to detect the presence of fire or flames in its vicinity. It typically consists of a sensor component that reacts to changes in temperature or infrared radiation associated with fire.

When activated, the sensor triggers an alarm or signal to alert users of the potential fire hazard, enabling prompt response and mitigation measures.

Fire sensor modules are commonly used in various settings, including residential buildings, commercial establishments, industrial facilities, and vehicles, to enhance fire safety and minimize the risk of property damage and personal injury.

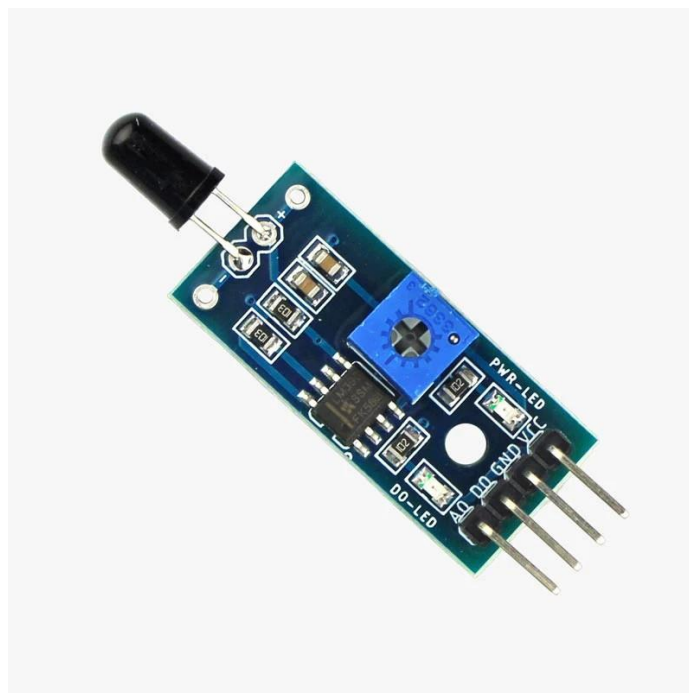



Ac To Dc Charger

An AC adapter is an external power supply that converts alternating current (AC) from a wall outlet to a direct current (DC) needed by an electronic device. Therefore, it is an AC/DC converter. When it supplies power to a battery-powered device, it is also accurate to describe it as a charger.

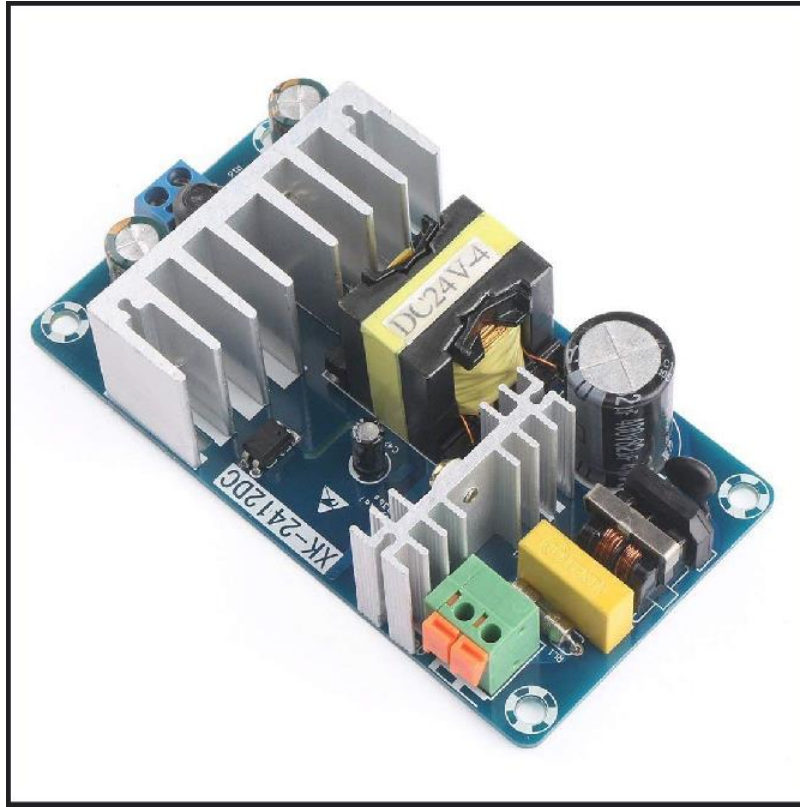

16x2 lcd display

The term LCD stands for liquid crystal display. It is one kind of electronic display module used in an extensive range of applications like various circuits & devices like mobile phones, calculators, computers, TV sets, etc.

These displays are mainly preferred for multi-segment light-emitting diodes and seven segments. The main benefits of using this module are inexpensive; simply programmable, animations, and there are no limitations for displaying custom characters, special and even animations, etc.

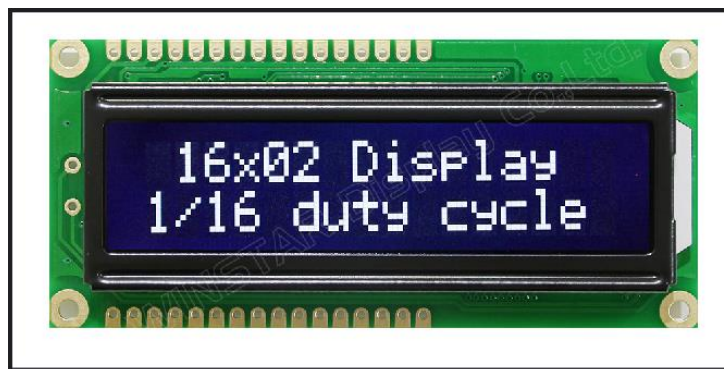



VI. ACTUAL MODEL

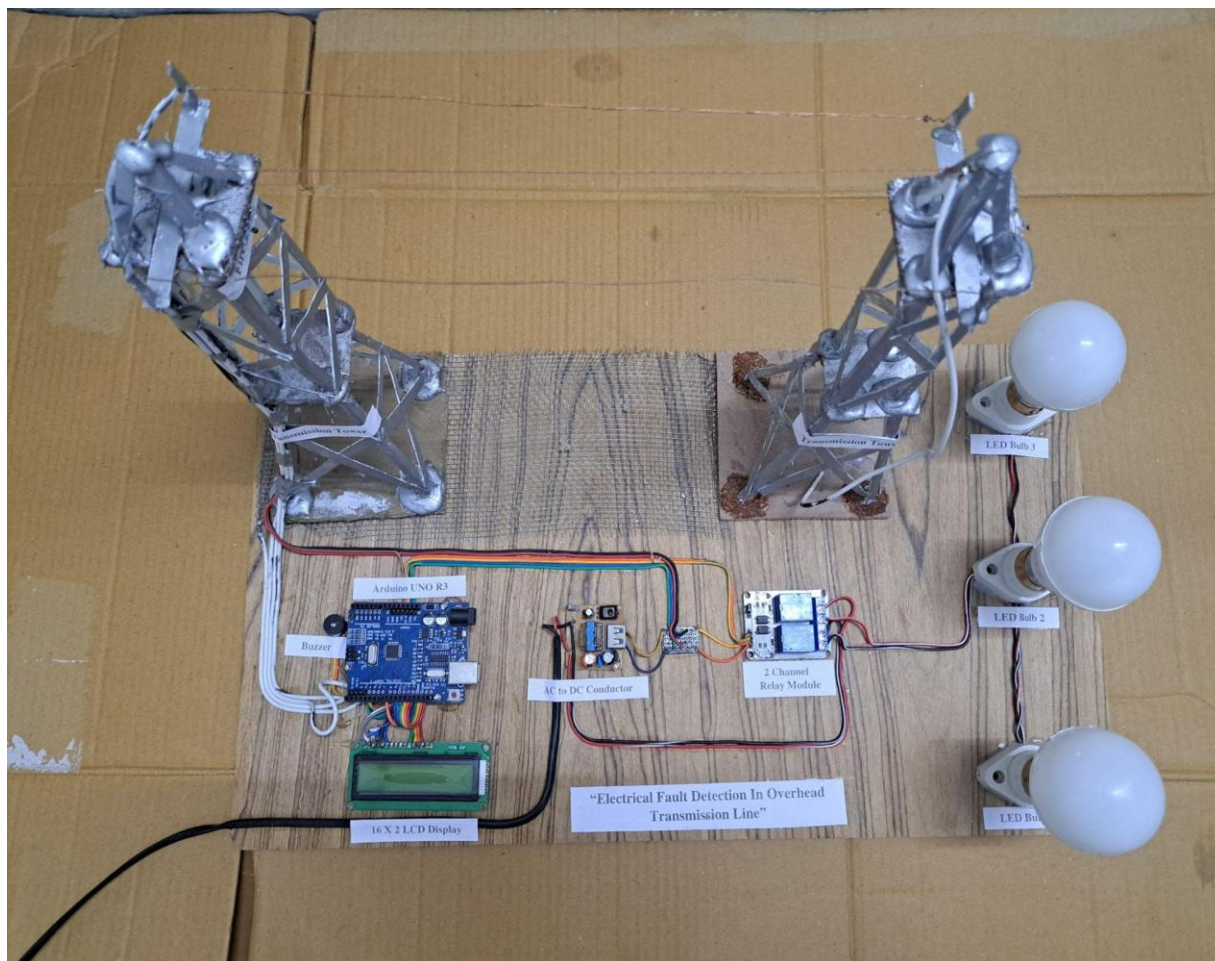

VII. METHODOLOGY

An Arduino-based engineering project for electrical fault detection in overhead transmission lines typically involves the use of sensors to monitor parameters such as current, voltage, and temperature along the line. The methodology begins with the installation of sensors at strategic points along the transmission line to continuously collect data.

The collected data is then processed by the Arduino microcontroller using algorithms designed to detect abnormal patterns indicative of faults, such as short circuits or line breaks. Upon detecting a fault, the system triggers alerts or initiates appropriate actions, such as isolating the faulty section or notifying maintenance personnel.

Additionally, machine learning techniques can be employed to improve fault detection accuracy by analyzing historical data and identifying patterns associated with different fault types. Overall, the Arduino-based approach offers a cost-effective and customizable solution for enhancing the reliability and efficiency of overhead transmission line operations.

VIII. CONCLUSION AND FUTURE WORK

Thus, in this paper a novel approach for detecting failure in the network of electric grid is proposed. The proposed approach can also be used for identifying electricity theft. In this paper, various sensors are used for identifying the symptoms that leads to network failure.

The detected issues are communicated through SMS to the concerned persons. The communication technique used in the proposed can be extended in future when the infrastructure of our country gets developed.



REFERENCES

- [1]. G. S. Nandakumar, "Fault Detection in Overhead Power Transmission," Ijcam.Esu, vol. 118, no. 8, pp. 377–381, 2018.
- [2]. Mr. Nilesh S.Wani, Dr. R. P. Singh . TRANSMISSION LINE FAULTS DETECTION- A REVIEW. Volume 7, Issue 2, March-April, 2016. WIKIPEDIA
- [3]. Chandra shekar. P. Transmission Line Fault Detection & Indication through RELAY 234, Volume2, Issue -5, 2014 .
- [4]. Sushil Chavhan, Vaibhav Barsagade, Abhijit Dutta, Shubhangi Thakre . Fault Detection in Power Line Using Relay.
- [5]. K. K. A. P. Eee, "Wide Area Fault Location in Transmission Line using Differential Protection Strategy," vol. 7, no. 02, pp. 2–6, 2019.
- [6]. A. Prasad, J. Belwin Edward, and K. Ravi, "A review on fault classification methodologies in power transmission systems: Part-II," J. Electr. Syst. Inf. Technol., vol. 5, no. 1, pp. 61–67, 2018.
- [7]. A. Sharma, A. Nirwan, and A. S. Shekhawat, "Fault Analysis on Three Phase Transmission Lines and its Detection," vol. 5, no. 2, pp. 229–233, 2017.
- [8]. M. Khandelwal, "A Review on Transmission Line Faults Detection," Int. J. Electr. Eng. Technol., vol. 7, no. 2, pp. 50–58, 2016.
- [9]. <https://www.studocu.com/in/document/delhi-technological-university/power-transmission-and-distribution/fault-detection-in-transmission-line/20738161>
- [10]. <https://ijari.org/assets/papers/5/2/IJARI-EE-17-06-102.pdf>

BIOGRAPHY



Gaurav Jichkar
(gauravjichkar888@gmail.com)



Rahul Mohurle
(rahulmohurle001@gmail.com)



Vikas Kalambe
(vikaskalambe2@gmail.com)