



SOLAR MOBILE CHARGER

ARUN KUMAR S

Department Of Electronics and Engineering, SJC Institute of Technology, Chickballapur, Karnataka India.

Abstract: A solar mobile charger is a device that harnesses the power of solar energy to charge portable electronic devices such as smartphones, tablets, and laptops. It is an eco-friendly and sustainable solution to the problem of charging devices on the go, especially in outdoor and off-grid environments where access to power outlets is limited or unavailable. The construction of a solar mobile charger typically consists of four key components: a solar panel, a battery, a charge controller, and a USB port for connecting to the device. The solar panel is the heart of the system, converting sunlight into electricity through the photovoltaic effect. The generated electricity is then stored in the battery, which acts as a buffer and ensures a steady supply of power to the device. The charge controller is a crucial component that regulates the flow of power between the solar panel, battery, and device. It prevents overcharging of the battery, which can cause damage or reduce its lifespan, and protects the device from voltage spikes or surges. The USB port provides a universal interface for connecting to various devices, making the solar mobile charger compatible with a wide range of devices and brands.

Keywords: Solar panel, Battery, charge controller.

I. INTRODUCTION

Solar energy is the energy produced directly by the sun and collected away, typically by the Earth. The sun constitutes its energy via a fissionable process. The process creates heat and electromagnetic radiation. Only a veritably small bit of the total radiation produced reaches the Earth. The radiation that reaches the Earth is the circular source of nearly every type of energy used moment. The radiation that does reach the Earth is the circular source of nearly every type of energy used moment. The exceptions are geothermal energy, and nuclear fission and emulsion. Indeed fossil energies owe their origins to the sun they were formerly living shops and creatures whose life was dependent upon the sun. Important of the world's needed energy can be supplied directly by solar power. further still can be handed laterally.

The practicality of doing so will be examined, as well as the benefits and downsides. In addition, the uses solar energy is presently applied to will be noted. Due to the nature of solar energy, two factors are needed to have a functional solar energy creator. These two factors are a collector and a storehouse unit. The stockpiler simply gathers the emission that falls on it and transforms a bit of it into another shape of energy(either electricity and fieriness or fieriness alone). The storehouse unit is needed because of the non-constant nature of solar energy; at certain times only a veritably small quantum of radiation will be entered. At night or during heavy pall cover, for illustration, the quantum of energy produced by the collector will be relatively small. The storehouse unit can hold the redundant energy produced during the ages of maximum productivity, and release it when the productivity drops. In practice, a provisory power force is generally added, too, for situations when the quantum of energy needed is lesser than both what's being produced and what's stored in the vessel.

II. LITERATURE SURVEY

SHAMA B. N. :Portable solar mobile chargers have gained increasing popularity in recent years, providing a convenient and environmentally friendly way to charge mobile devices on the go. This literature review aims to explore the current state of research on portable solar mobile chargers, including their technology, effectiveness, and potential impact on society.

The technology of Portable Solar Mobile Chargers:Portable solar mobile chargers use photovoltaic cells to convert sunlight into electrical energy, which can then be used to charge mobile devices... Researchers have focused on improving the efficiency of these photovoltaic cells, as well as the design and functionality of the chargers themselves.

Effectiveness of Portable Solar Mobile Chargers: Studies have shown that portable solar mobile chargers can effectively charge mobile devices, but their effectiveness depends on a variety of factors... Researchers have also explored the use of portable solar mobile chargers in emergencies, such as natural disasters or power outages, and have found them to be useful tool for providing access to electricity in these situations.



Potential Impact on Society: Portable solar mobile chargers have the potential to significantly impact society, particularly in areas where access to electricity is limited. Researchers have explored the use of portable solar mobile chargers in developing countries, where they can provide a reliable and sustainable source of energy for mobile devices, which are becoming increasingly important for communication, education, and healthcare.

III. BLOCK DIAGRAM

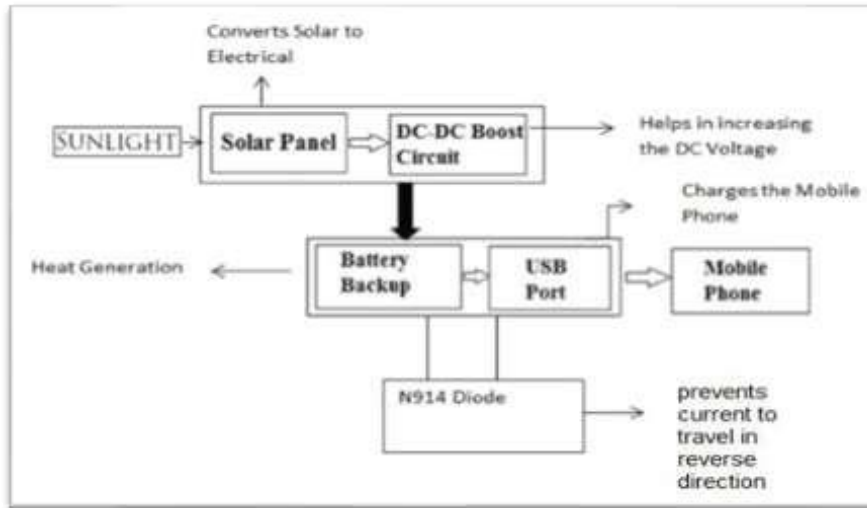

Fig.1: Block Diagram.

IV. WORKING

A portable solar phone charger can be charged by sunlight and electricity. your phone, iPod, etc. collects solar energy for charging.

- Solar phone chargers use solar panels to charge the phone's batteries. They are an alternative to phone chargers and sometimes plug into a power outlet.
- There are also solar cell phones that can be permanently installed in public areas such as streets, parks, and squares. One of the models listed as the first in the world by the European Commission is Strawberry Tree, a public solar power plant developed by Strawberry Energy. The solar power plant took first place among consumers at the European Union Sustainable Energy Week (EUSEW) 2011. • Some phone models have a builtin solar charger and phones are sold with the GSM phone model.

V. ACTUAL MODEL



Fig.9. Actual Model.



VI. CONCLUSION

Solar mobile chargers are a safe and environmentally friendly solution for charging portable electronics on the go. It has four main components, a solar panel, a battery, a controller, and a USB port, and they are much better than electronic devices. Solar mobile chargers have great potential for future R&D, including performance improvements, research of new materials and technologies for batteries, and exploration of new applications. With continued progress, solar mobile chargers can become more efficient, affordable, and accessible to many users, promoting sustainability and energy independence. Solar Phone Chargers can be used for smartphones, tablets, cameras, etc.

It is an efficient and environmentally friendly product that uses solar energy to charge mobile devices. The structure of a solar mobile charger usually includes a solar panel, battery, controller, and USB port. When exposed to sunlight, the solar panel generates electricity to charge the battery, which can be used to charge mobile devices via the USB port. Solar mobile chargers have many advantages over traditional power lines such as portability, convenience, and efficiency. It also reduces carbon emissions and environmental impact.

REFERENCES

- [1] R. A. MASTROMAURO, M. LISERRE, AND A. DELL 'AQUILA, "CONTROL ISSUES IN SINGLE-STAGE PHOTOVOLTAIC SYSTEMS: MPPT, CURRENT, AND VOLTAGE CONTROL," IEEE TRANS. IND. INFORMAT., VOL. 8, NO. 2, PP. 241–254, MAY. 2012.
- [2] Z. Zhao, M. Xu, Q. Chen, J. S. Jason Lai, and Y. H. Cho, "Derivation, analysis, and implementation of a boost– buck converter-based high-efficiency pv inverter," IEEE Trans. Power Electron., vol. 27, no. 3, pp. 1304– 1313, Mar. 2012.
- [3] M. Hanif, M. Basu, and K. Gaughan, "Understanding the operation of a Z-source inverter for photovoltaic application with a design example, IET Power Electron., vol. 4, no. 3, pp. 278–287, 2011.
- [4] J.-M. Shen, H. L. Jou, and J. C. Wu, "Novel transformer-less grid-connected power converter with negative grounding for photovoltaic generation system," IEEE Trans. Power Electron., vol. 27, no. 4, pp. 1818– 1829, Apr. 2012.
- [5] Mohammed O Badawy, Ahmet S Yilmaz, Yilmaz Sozer, Iqbal Husain. Parallel Power Processing Topology for Solar PV Applications. IEEE TRANSACTIONS ON INDUSTRY APPLICATIONS, VOL. 50, NO. 2, MARCH/APRIL 2014
- [6] Solar Electricity Engineering of Photovoltaic System, by Lorezo E.
- [7] Power Electronics, by Bhimbra P.S.
- [8] An Energy-aware Survey on Mobile-phone Chargers, p. 8. Bonner, J. (2012), Portable Solar Panel Charging Station, p.31.



- [9] Renewable Energy and Energy Efficiency Incentives: A summary of Federal Programs, p.5. de Groot, H. (2008),
- [10] http://www.tpub.com/content/neets/14175/css/14175_130.htm
- [11] <http://www.solar-facts.com/panels/>
- [12] <http://www.national.com/ds/LM/LM723.pdf>
- [13] <http://www.facstaff.bucknell.edu/mastascu/elessonshtml/LC/Capac1.htm>
- [14] http://www.allaboutcircuits.com/vol_3/chpt_4/1.html
- [15] http://www.allaboutcircuits.com/vol_3/chpt_4/1.html#03071.png
- [16] <http://science.howstuffworks.com/environmental/energy/solarcell.htm/battery.htm>
- [17] http://en.wikipedia.org/wiki/Electrical_resistance_and_conductance
- [18] <http://science.howstuffworks.com/environmental/energy/solar-cell1.htm>
- [19] http://en.wikipedia.org/wiki/Electrical_element
- [20] <http://en.wikipedia.org/wiki/Ohm>