



Design and development of Sewage Drain Monitoring and alert system using IoT and LoRa Technology

P. Shanmukha Kumar¹, T. Srujan², Mohd. Faraz³

Assistant Professor, Computer Science & Engineering- Internet of Things, Malla Reddy University, Hyderabad, India¹

Computer Science & Engineering- Internet of Things, Malla Reddy University, Hyderabad, India²

Abstract — Urban sewage systems frequently face issues such as blockage and overflow, resulting in unhygienic conditions, health hazards, and damage to public infrastructure. Manual inspection of sewage drains is unsafe, time-consuming, and inefficient. To address these challenges, this project focuses on the design and development of a sewage drain monitoring and alert system using IoT and LoRa technology. The system continuously monitors sewage water levels using sensors and detects abnormal conditions at an early stage.

The sensed data is processed by a microcontroller and transmitted over long distances using LoRa communication, which offers low power consumption and wide coverage. A LoRa gateway forwards the data to a cloud platform for real-time monitoring and alert generation. When overflow or blockage is detected, instant notifications are sent to concerned authorities. The proposed system is cost-effective, reliable, and scalable, making it suitable for smart city sewage management and public health improvement.

Keywords - Sewage Monitoring, IoT, LoRa, Gas Sensor, Level Sensor, Smart Drainage, Alert System

I. INTRODUCTION

Rapid urbanization has significantly increased the complexity of urban infrastructure management, particularly in the area of sewage systems.

Traditional methods of monitoring sewage drains rely heavily on manual inspection, which is not only time-consuming and labour-intensive but also fails to provide real-time data necessary for prompt decision-making. This leads to frequent blockages, overflows, and gas leaks that pose serious health hazards, environmental contamination, and economic losses. The proposed Sewage Drain Monitoring and Alert System addresses these challenges by integrating Internet of Things (IoT) technology with Long Range (LoRa) wireless communication to create an intelligent, automated monitoring solution capable of detecting critical conditions in real time.

The Internet of Things enables seamless connectivity between physical sensors deployed in sewage drains and cloud-based platforms where data is processed, analysed, and stored. LoRa technology complements this by providing a low-power, wide-area communication protocol that allows sensors to transmit data over long distances (up to 10-15 kilometers) while consuming minimal energy.

II. WORKING PRINCIPLE

A. Colorimetric Detection Mechanism

The system is based on continuous sensing, data processing, long-range transmission, and alert. Sensors installed inside sewage drains measure water level, toxic gas concentration, and flow conditions. The microcontroller processes sensor data and compares it with predefined safety thresholds. Processed data is transmitted wirelessly using LoRa to a remote monitoring unit. If abnormal conditions are detected, alerts are triggered locally and remotely.

B. Optical Sensing Principle

The System Uses:

The properties of light (absorption, emission, scattering, fluorescence) to detect and measure physical, chemical, or biological parameters. It is non-contact, highly sensitive, and suitable for real time monitoring.



Sewage Monitoring, IoT, LoRa, Gas Sensor, Level Sensor

III. MATHEMATICAL MODELLING AND CALIBRATION

The system checks whether these values are normal or abnormal.

Model

Let:

- L = water level
- Q = flow rate
- G = gas concentration
- T = temperature

The system status can be written as:

$$S=f(L,Q,G,T)S = f(L, Q, G, T)S=f(L,Q,G,T)$$

Where S shows whether the drain condition is normal or alert.

Conditions

- If water level is high → Overflow alert
- If flow rate is low → Blockage alert
- If gas level is high → Gas alert
- If temperature is high → Warning alert

This mathematical model helps the system to detect drain problems automatically.

A. Architecture

The system consists of sensors, microcontroller, LoRa module, gateway, cloud, and user dashboard.

Sensors collect drain data like water level, flow, gas, and temperature.

The microcontroller processes the data.

The LoRa module sends the data to the gateway. Then the data is stored in the cloud and shown on the mobile app or dashboard.

Sensors → Microcontroller → LoRa → Gateway → Cloud → User

This architecture helps in real-time sewage drain monitoring.

Alert Mechanism:

- Water level > safe limit → Overflow alert
- Flow rate < minimum limit → Blockage alert
- Gas concentration > threshold → Gas leakage alert
- Temperature > safe value → Warning alert

When any value crosses its threshold, the microcontroller immediately triggers an alert.



Fig 1: Architecture Diagram

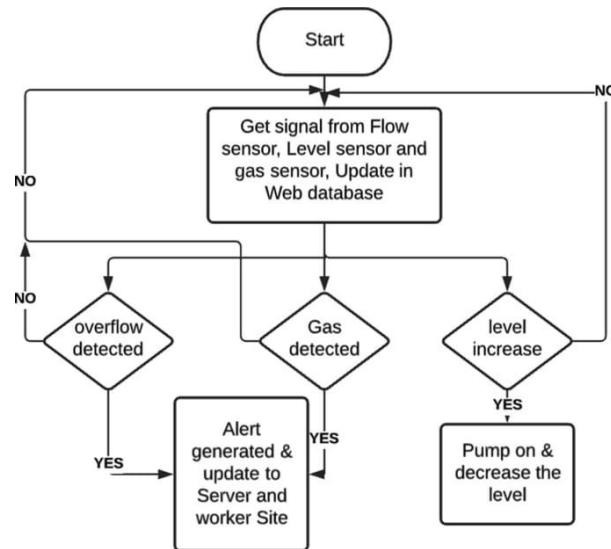

The Design and Development of Sewage Drain Monitoring and Alert System using IoT and LoRa Technology consists of multiple integrated layers that work together to provide real-time monitoring and early warning of hazardous conditions in sewage systems. At the sensing layer, various sensors such as an ultrasonic sensor, gas sensor (for detecting H₂S and CH₄), and flow sensor are installed inside the sewage drain. The ultrasonic sensor measures the water level using the echo time principle, the gas sensor monitors toxic gas concentration to ensure worker safety, and the flow sensor measures discharge rate to detect blockages. These sensors continuously collect environmental data and send analog or digital signals to the processing unit.

The processing layer consists of a microcontroller such as ESP32 or Arduino integrated with a LoRa module (e.g., SX1278). The microcontroller reads the sensor data, applies calibration equations to improve accuracy, filters noise if required, and compares the values with predefined threshold limits. If the water level exceeds 85% of the drain height, if toxic gas concentration crosses the safe limit, or if the flow rate drops abnormally indicating blockage, the system generates an alert condition. The processed data is then formatted into a structured data packet containing node ID, water level, gas concentration, flow rate, and system status.

In the communication layer, LoRa technology is used for long-range and low-power wireless transmission. The sensor node transmits the data packet to a LoRa gateway located within a few kilometres. LoRa is preferred because it offers low energy consumption, deep penetration capability suitable for underground environments, and wide coverage, making it ideal for smart city infrastructure monitoring.

B. PROCESS

The cloud-based monitoring and alert mechanism enhances decision-making by providing data storage, visualization, and instant notifications to municipal authorities or maintenance teams. This reduces manual inspection, prevents flooding, protects worker safety, and improves overall sanitation management. IoT and LoRa Technology consists of multiple integrated layers that work together to provide real-time monitoring and early warning of hazardous conditions in sewage systems.

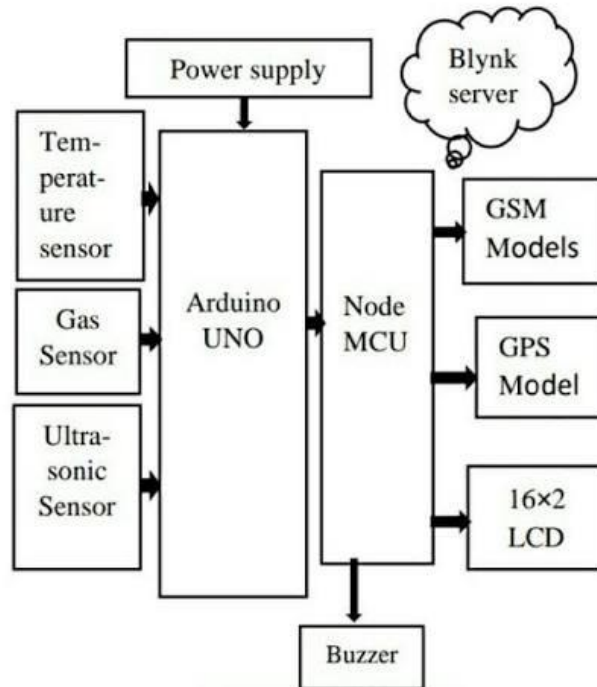
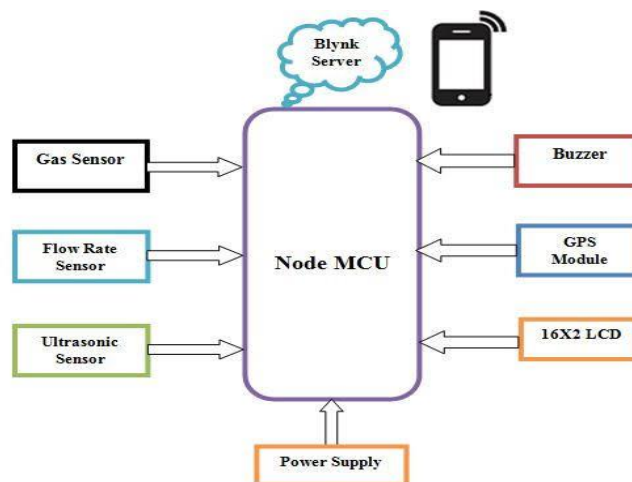

Fig 2: process flow diagram

The process flow of the Design and Development of Sewage Drain Monitoring and Alert System using IoT and LoRa Technology begins with system initialization, where the microcontroller (ESP32/Arduino) powers up, initializes all connected sensors (ultrasonic, gas, and flow sensors), and establishes communication with the LoRa module. After initialization, the sensing phase starts. The ultrasonic sensor measures the distance to the water surface to calculate the sewage water level, the gas sensor detects toxic gases such as hydrogen sulfide and methane.

IV DATA FLOW DIAGRAM



The data flow begins at the external entities, which are the sewage drain environment and the municipal monitoring authority. The raw sensor data flows to the processing unit, which consists of a microcontroller integrated with a LoRa module. In this stage, the microcontroller performs analog -to-digital conversion (if required), applies calibration equations, filters noise, and converts the data into meaningful engineering units such as meters, ppm, or litres per second. The processed data is then compared with predefined threshold values stored in the system. Based on this comparison, a status indicator (normal, warning, or critical) is generated. All processed parameters along with node identification are then structured into a formatted data packet. This data packet flows through the communication channel using LoRa technology to the LoRa gateway. The gateway acts as a data forwarding process that converts LoRa packets into internet based protocols and transmits them to the cloud server.



V. RESULTS

The developed sewage drain monitoring system was successfully implemented and tested under various conditions to evaluate its performance. The ultrasonic sensor accurately measured the sewage level, and the values changed appropriately when objects were placed at different distances, indicating reliable level detection. Similarly, the MQ135 gas sensor responded effectively to the presence of gases, showing higher values when exposed to smoke or pollutants and stable readings under normal conditions.

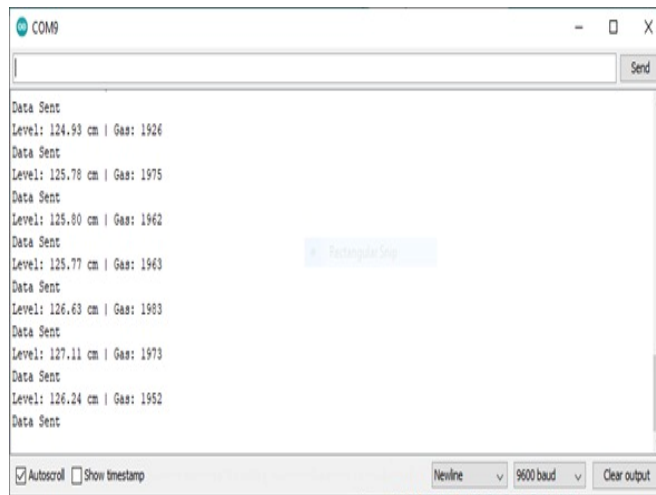

Fig 4: Sender sends the Data

Screenshot 4.2.3 Sender Module The ESP32 microcontroller efficiently processed the sensor data and correctly identified the system status based on predefined threshold values. When the sewage level dropped below the threshold or gas concentration exceeded the safe limit, the system successfully generated alerts such as “OVERFLOW” and “GAS_ALERT.” The buzzer also activated instantly, providing a real-time local warning.

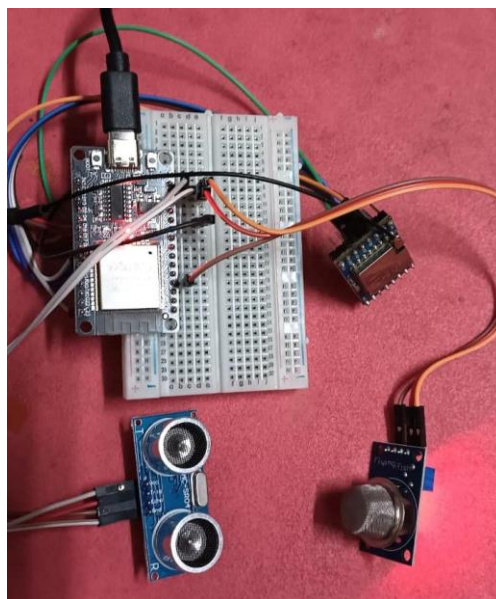

Fig 5: Sender Module

The LoRa communication module demonstrated reliable long-range data transmission between the ESP32 sender and Arduino Nano receiver. The receiver unit consistently displayed the transmitted data without significant loss or delay.



Overall, the system performed effectively in real-time monitoring, alert generation, and data transmission, proving its suitability for practical sewage management applications.

The developed sewage drain monitoring system was successfully implemented and tested under various conditions to evaluate its performance. The ultrasonic sensor accurately measured the sewage level, and the values changed appropriately when objects were placed at different distances, indicating reliable level detection. Similarly, the MQ135 gas sensor responded effectively to the presence of gases, showing higher values when exposed to smoke or pollutants and stable readings under normal conditions.

The ESP32 microcontroller efficiently processed the sensor data and correctly identified the system status based on predefined threshold values. When the sewage level dropped below the threshold or gas concentration exceeded the safe limit, the system successfully generated alerts such as "OVERFLOW" and "GAS_ALERT." The buzzer also activated instantly, providing a real-time local warning.

The LoRa communication module demonstrated reliable long-range data transmission between the ESP32 sender and Arduino Nano receiver. The receiver unit consistently displayed the transmitted data without significant loss or delay.

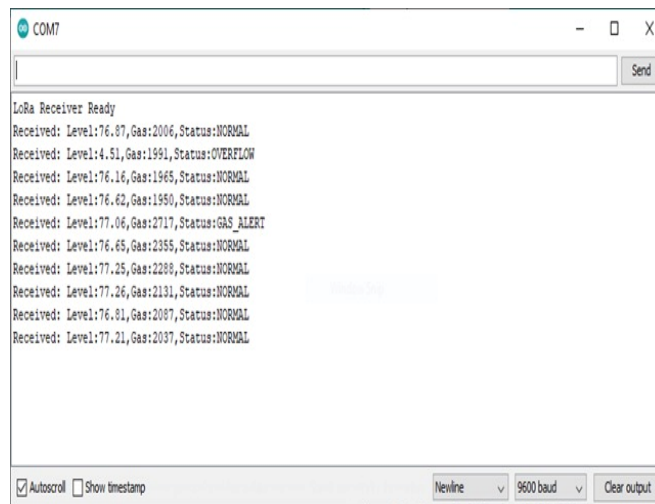

Fig 6: Receiver received the Data

The system was tested under different environmental conditions to evaluate its consistency and stability. During testing, the ultrasonic sensor provided reliable distance measurements with minimal variation, even when the surface conditions of the liquid changed slightly. The gas sensor initially showed fluctuating values due to warm-up time but gradually stabilized after continuous operation. This behaviour confirms the importance of calibration and proper sensor conditioning before deployment. Once stabilized, the sensor readings remained consistent and responded accurately to changes in gas concentration.

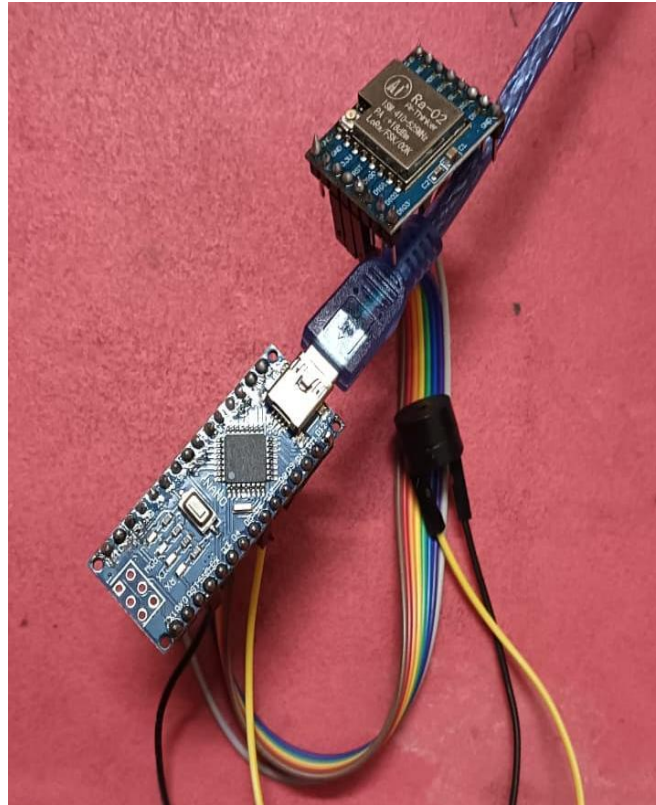

Fig 7: Receiver module

The performance of the LoRa communication module was also analysed by varying the distance between the sender and receiver units. It was observed that the system maintained stable communication over short and moderate distances without any packet loss. The transmitted data was received clearly and in the correct format at the receiver end. The low power consumption and long-range capability of LoRa make it highly suitable for underground and remote monitoring applications, where conventional communication methods may not be effective.

The ESP32 microcontroller efficiently processed the sensor data and correctly identified the system status based on predefined threshold values. When the sewage level dropped below the threshold or gas concentration exceeded the safe limit, the system successfully generated alerts such as “OVERFLOW” and “GAS_ALERT.” The buzzer also activated instantly, providing a real-time local warning. The performance of the LoRa communication module was also analysed by varying the distance between the sender and receiver units. It was observed that the system maintained stable communication over short and moderate distances without any packet loss. The transmitted data was received clearly and in the correct format at the receiver end. The low power consumption and long-range capability of LoRa make it highly suitable for underground and remote monitoring applications, where conventional communication methods may not be effective.

VI. CONCLUSION

The Design and Development of Sewage Drain Monitoring and Alert System using IoT and LoRa Technology provides an efficient, reliable, and cost effective solution for real-time monitoring of sewage infrastructure. By integrating sensors for water level, gas concentration, and flow rate with a microcontroller-based processing unit, the system continuously observes critical environmental parameters inside drainage systems. The application of mathematical modelling and calibration techniques ensures accurate measurement and reliable detection of abnormal conditions such as overflow, blockage, and toxic gas accumulation. The use of LoRa technology enables long-range, low-power communication, making the system suitable for underground and large-scale urban deployments.



The cloud-based monitoring and alert mechanism enhances decision-making by providing data storage, visualization, and instant notifications to municipal authorities or maintenance teams. This reduces manual inspection, prevents flooding, protects worker safety, and improves overall sanitation management. The modular and scalable architecture allows deployment across multiple drainage points, making it adaptable for smart city. The proposed system demonstrates how IoT and long-range wireless communication technologies can significantly improve public health, environmental safety, and infrastructure maintenance through intelligent monitoring and early warning mechanisms.

REFERENCES

- [1] L. Atzori, A. Iera and G. Morabito, "The Internet of Things: A survey," IEEE Communications Magazine, vol. 54, no. 15, pp. 278–284, 2010.
- [2] U. Raza, P. Kulkarni and M. Sooriyabandara, "Low Power Wide Area Networks: An Overview," IEEE Communications Surveys & Tutorials, vol. 19, no. 2, pp. 855–873, 2017.
- [3] F. Adelantado, X. Vilajosana, P. TusetPeiro, B. Martinez, J. Melia-Segui and T. Watteyne, "Understanding the Limits of LoRaWAN," IEEE Communications Magazine, vol. 55, no. 9, pp. 34–40, 2017.
- [4] S. Madakam, R. Ramaswamy and S. Tripathi, "Internet of Things (IoT): A Literature Review," Journal of Computer and Communications, vol. 3, no. 5, pp. 164–173, 2015.
- [5] A. Augustin, J. Yi, T. Clausen and W. M. Townsley, "A Study of LoRa: Long Range & Low Power Networks for the Internet of Things," Sensors Journal, vol. 16, no. 9, 2016.
- [6] H. Boyes, B. Hallaq, J. Cunningham and T. Watson, "The Industrial Internet of Things (IIoT): An analysis framework," Computers in Industry, vol. 101, pp. 1–12, 2018.
- [7] J. Gubbi, R. Buyya, S. Marusic and M. Palaniswami, "Internet of Things (IoT): A vision, architectural elements, and future directions," Future Generation Computer Systems, vol. 29, no. 7, pp. 1645–1660, 2013.
- [8] M. Centenaro, L. Vangelista, A. Zanella and M. Zorzi, "Long-range communications in unlicensed bands: The rising stars in IoT and smart city scenarios," IEEE Wireless Communications, vol. 23, no. 5, pp. 60–67, 2016.
- [9] World Health Organization (WHO), "Guidelines on sanitation and health," WHO Press, Geneva, 2018. □ [10] K. Ashton, "That 'Internet of Things' Thing," RFID Journal, 2009.