



# Study of Design and Mobility Approaches in Rocker–Bogie Suspension Systems

Sarthak Sharma<sup>1</sup>, Utkarsh Nehwal<sup>2</sup>, Yash Kaushik<sup>3</sup>, Shrikant<sup>4</sup>, Sushant Dhasmana<sup>5</sup>,

Dr. Uruj Jaleel<sup>6</sup>, Dr. Satish Kumar Soni<sup>7</sup>

Student, MCA, Meerut Institute of Engineering and Technology, U.P. India<sup>1</sup>

Student, MCA, Meerut Institute of Engineering and Technology, U.P. India<sup>2</sup>

Student, MCA, Meerut Institute of Engineering and Technology, U.P. India<sup>3</sup>

Student, MCA, Meerut Institute of Engineering and Technology, U.P. India<sup>4</sup>

Student, MCA, Meerut Institute of Engineering and Technology, U.P. India<sup>5</sup>

Professor, MCA, Meerut Institute of Engineering and Technology, U.P. India<sup>6</sup>

Associate Professor, MCA, Meerut Institute of Engineering and Technology, U.P. India<sup>7</sup>

**Abstract:** Navigating rugged, unpredictable terrain is a significant engineering challenge for both off-road vehicles on Earth and rovers on Mars. When the ground becomes extremely rough, traditional suspension systems typically have trouble keeping a car stable and maintaining traction. The rocker-bogie suspension is useful in this situation. It successfully resolves these issues by maintaining all wheels in continuous contact with the ground, which makes it considerably simpler to crawl over big obstacles without tipping. It was first created for space missions. The rocker-bogie mechanism is thoroughly examined in this work. We examine its background, the workings of its mechanics, important design decisions, and the specifics of how it safely climbs over obstacles. Lastly, we examine the practical applications of utilizing this space-age technology.

**Keywords:** Rocker–bogie suspension, rover mobility, rough terrain navigation, off-road vehicles, suspension systems.

## I. INTRODUCTION

Robotic cars and autonomous platforms of today are being forced into more challenging and unpredictable conditions [6]. The majority of conventional suspension systems, such as simple rigid axles or spring-damper configurations, are primarily designed for predictable and smooth roads. Their performance frequently collapses when you add loose dirt, steep slopes, or rocks to the mix. The rocker-bogie system is one of the more successful solutions that engineers have looked at to address this. This architecture has already demonstrated its value on several space missions by scaling enormous barriers without losing its equilibrium [1]. It was initially designed to withstand the harsh environment of other worlds. In order to understand why the rocker-bogie system is becoming such a game-changer for high-stakes mobility, both in deep space and for specialized off-road use here on Earth, this study examines the system's operation in further detail.



Figure 1: Structure of Rocker Bogie

## II. EVOLUTION OF THE ROCKER–BOGIE SYSTEM

The theory of articulated suspension is not particularly new; in fact, it originated in big industrial tools and early military tanks, where “bogie” systems originally served to transfer heavy objects across uneven terrain. However, NASA’s Jet Propulsion Laboratory (JPL) is where the improved “rocker bogie” layout that we are familiar with today genuinely took shape. They wanted something that would not only endure on Mars but flourish there, where there are no roads and no one to turn a rover back over if it turned [2]. The world took note in 1997 when the tiny Opportunity rover rolled off the Pathfinder lander and started investigating Planet territory [2]. The evidence of concept changed everything. Since then, NASA hasn’t really looked back. The legendary “twin” rovers, Spirit and Opportunity, accepted that straightforward idea and added years to its duration. Afterwards, the system needed to be significantly increased when Curiosity and eventually Perseverance arrived. These were now SUV-sized robots rather than little ones. The robustness of this innovation is shown by scaling the rocker-bogie mechanism to manage that kind of load while still managing bone-chilling temperature changes and sharply cut volcanic sandstone. It’s not only about rock climbing; it’s about a design that is both skilled enough to keep six wheels stuck to the ground regardless of how difficult the path gets and simple enough to not break.

## III. STRUCTURAL CONFIGURATION OF ROCKER–BOGIE SUSPENSION

The perfect symmetry of the rocker-bogie design is its major feature. Each of the two similar arrangements on each side of the rover’s main body is a master class in intelligent geometry. Here’s a closer look at how these components work: The System’s Architecture The primary “backbone” of the suspension is the Rocker Arm. It is a big main link that is fastened straight to the structure of the car [7]. It has one wheel on its front end. It can swing up or down in response to changes in the terrain because it is permitted to pivot. The Bogie Link is a supplementary, smaller component that is attached to the back of the rocker arm. It contains the final two wheels. The wheels can “walk” over rocks without the entire vehicle jumping upward because to this “link-within-a link” arrangement [7]. Probably the most amazing component of the entire gadget is the Movable Gate. In addition to being independent, the left and right rocker arms are connected by a physical differential gear or bar. The differences cause the right side to react when either side slides up after hitting a 10-inch rock, so “averaging out” the movement [1]. This keeps the main body—which houses the pricey cameras and sensors—much more level than it would otherwise be.

## IV. OPERATING PRINCIPLE

The rocker-bogie system’s ability to effortlessly handle a large rock is its true brilliance. It uses silent motion transfer instead of turbines or computer sensors to change each wheel’s height. This essentially means that all of the reasoning is done by the linkages that are mechanical. Instead of just smashing into the rover’s main body when one tire strikes a bump, the force spreads through the bogie and rocker joints [2]. How it Really “Climbs” This system approaches a barrier more like a slow-motion crawl than a drive. It has a four-step beat that is quite accurate and precise. The front wheel first makes contact with the leading edge. The front wheel may swing upward and begin to “bite” into the obstruction due to the rocker arm’s pivot. It successfully draws the remaining suspension in the direction of the rock. Pivot Shift: The rocker arm rotates as the front wheel rises. In fact, by lifting the middle bogie construction, this movement prepares the subsequent set of wheels for the climb. The Middle Push: The barrier is now struck by the middle wheel. The front wheel



is already on top at this stage, giving the centre wheel the forward pull it needs to roll up and over. The Final Anchor: Lastly, the rear wheel—which has been providing steady pushing power this whole time—is pulled over the top by the four wheels that are already in front of it. [1] The Significance of This for Stability At least five of the six wheels are often attached to the ground during this entire “walking” period. The rover has amazing traction as a result. The differential mechanism is balancing the left and right sides in the background while this is taking place. The differential makes sure the main chassis simply turns by roughly six inches when the left front wheel is a foot in the air. The vehicle avoids such rapid, sharp jolts that may break a camera lens or tip the rover over by distributing its motion across so many distinct joints. These machines are able to deal with rocky fields that would leave a premium 4x4 elevated and stuck because of this slow and steady method.

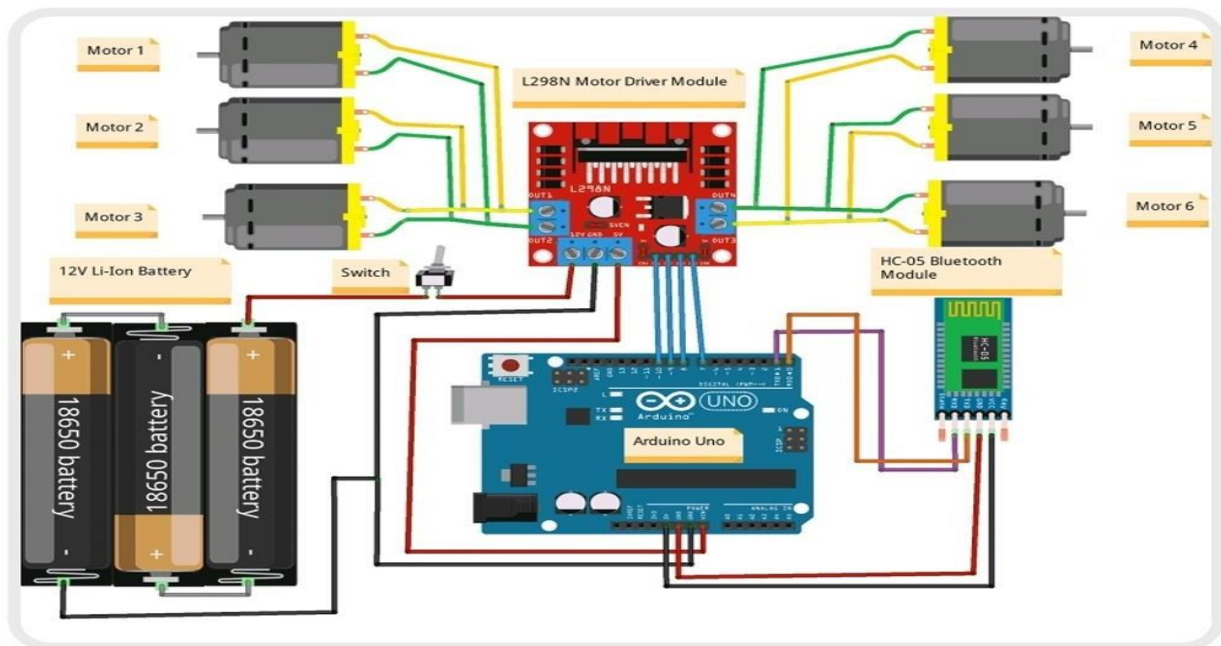

FIGURE 2: CIRCUIT OF ROCKER BOGIE

## V. DESIGN METHODOLOGY

A number of practical design choices must be made while creating a rocker-bogie suspension system, taking into mind the vehicle’s working environment as well as the mechanism’s construction. First, the designer needs to determine the vehicle’s entire mass, the estimated payload it will carry, and the kind of ground it will operate on. These elements are essential in determining the suspension components’ shape and strength. In order for the vehicle to maintain suitable stability and travel smoothly across irregular or rough surfaces, adequate rims are then chosen by taking into account factors like rim diameter and print pattern. Determining the proper rocker and bogie link thicknesses is another crucial step. The design of these attachments must let the wheels to adjust to uneven terrain and barriers while main training the vehicle’s stability. For the suspension system to function smoothly and flexibly, the pivot joints that connect the rocker and bogie arms must also be carefully planned. After these structural components are identified, a three-dimensional computer-aided design (CAD) model of the system is often created using programs like SolidWorks. This model facilitates the analysis of the component’s arrangement ahead to manufacture and aids in visualizing the overall assembly. Lastly, kinematic and stability simulations are used to investigate the behaviour of the suspension system when it is moving and navigating obstacles. Maintaining a low centre of gravity and making sure the load is distributed equally among all the wheels are given significant consideration throughout the design process. These design factors are crucial for enhancing the rocker-bogie suspension system’s general efficiency, stability, and balance.

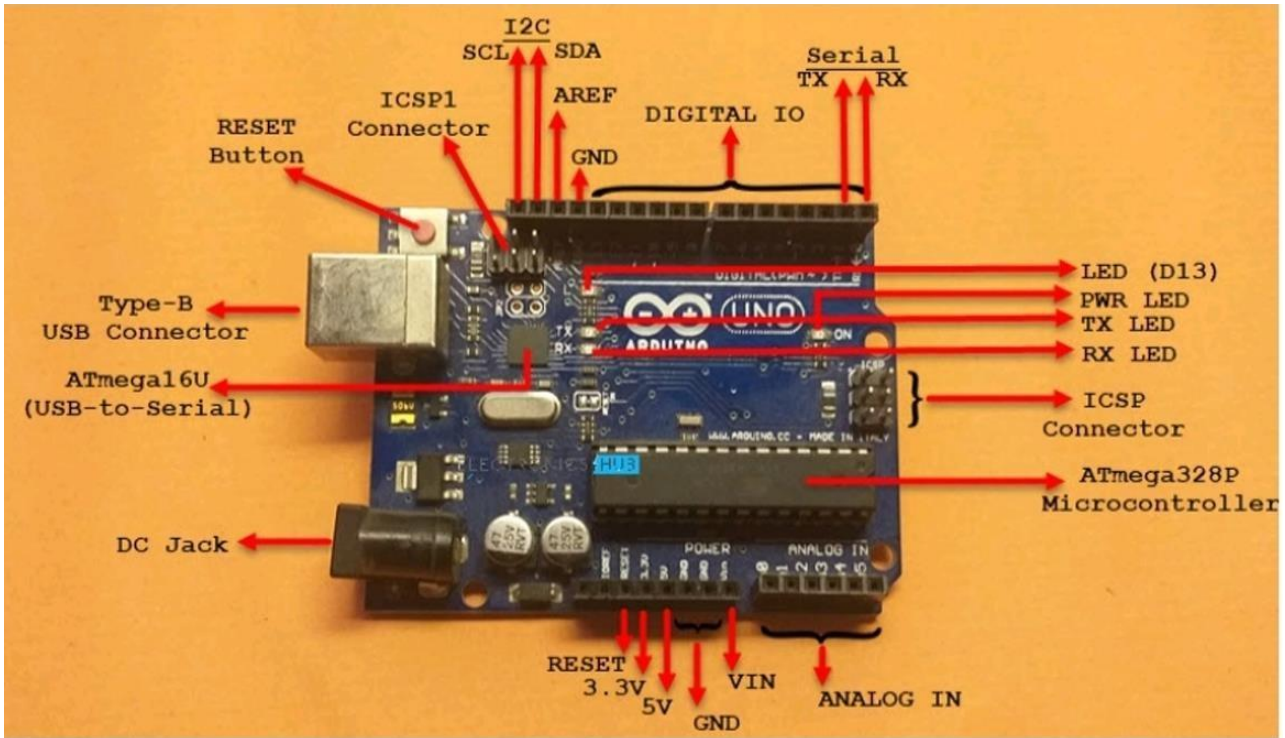

Figure 3: Arduino Pin Diagram

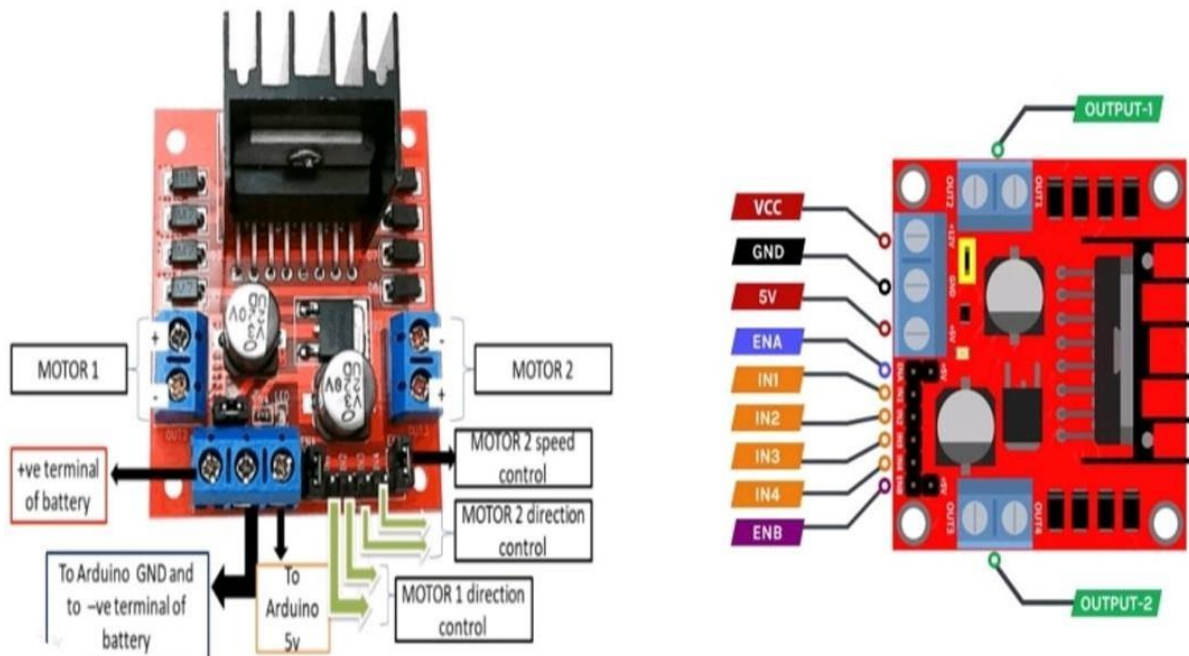

Figure 4: Motor Driver

**VI. OBSTACLE NEGOTIATION AND STABILITY CHARACTERISTICS**

The rocker-bogie suspension system’s exceptional capacity to navigate over obstacles without losing stability is one of its greatest advantages. This technology allows vehicles to climb over barriers that are nearly twice the diameter of their



wheels. This feature makes the system ideal for uneven and difficult terrain, where conventional suspension systems frequently have trouble operating efficiently. The special configuration of the bogie and rocker linkages allows the wheels to stay in contact with the ground even when the vehicle is traveling over uneven surfaces like steps or rocks. This constant contact increases traction and aids in the vehicle's ability to stay balanced while moving. When one side encounters a rapid pressure or compression, the car may tilt considerably in many traditional suspension systems that primarily rely on springs. These circumstances can make tipping more likely, particularly when the car is traveling over uneven or sloping terrain. This issue is handled differently by the rocker-bogie mechanism. It employs a set of stiff mechanical connections that more uniformly transfer the load over all of the wheels rather than relying on springs. Consequently, the entire structure shares the stresses produced during motion, which lessens the strain on individual parts and enhances the vehicle's overall stability.

## VII. APPLICATION AREAS

### 7.1 Space Exploration Vehicles:

The usage of the rocker-bogie suspension mechanism in planetary rovers intended for interplanetary missions is well documented. In settings where maintenance and repair are nearly impossible, this suspension system has shown to be quite reliable. The mechanism can operate efficiently for extended periods of time without the need for frequent modifications since it uses a straightforward mechanical linkage instead of intricate springs or hydraulic systems. With all of its wheels in contact with the ground, the design enables the rover to travel slowly but steadily over rocky terrain, craters, and uneven terrain. For scientific missions, when the vehicle must securely transport cameras, sensors, and other delicate gear while traversing uncharted territory, this stability is crucial.

### 7.2 Terrestrial and Industrial Applications:

The rocker-bogie suspension system has been used extensively in planetary rovers designed for travel between planets. In environments where maintenance and repair are practically impossible, this suspension system has proven to be highly dependable. Because it makes use of a simple mechanical connection rather than complex springs or hydraulic systems, the mechanism can function effectively for long periods of time without requiring regular alterations. The design allows the rover to move slowly but steadily over uneven, rocky, and cracked ground with all of its wheels in contact with the ground. This stability is essential for scientific missions when the vehicle must safely convey cameras, sensors, and other weak equipment while traveling across unknown lands. In sectors like mining and agriculture, where machinery frequently works on uneven or rocky terrain, the mechanism may also be helpful. The equipment's mobility and safety are enhanced in such settings by a suspension system that can manage angles, rocks, and soil differences. Rescue operations and disasters management are another promising field. In an emergency, robots with a rocker-bogie suspension system may move across rubble, collapsed buildings, and garbage while looking for survivors. Therefore, this suspension system can enhance the overall performance, stability, and adaptability of vehicles operating in difficult situations with appropriate design revisions.

## VIII. ADVANTAGES AND CONSTRAINTS

Advantages:

### 1. High Terrain Adaptability

When driving on rough or difficult terrain, the rocker-bogie suspension design works very effectively. Because of its engineering, the wheels can adapt to the ground's surface, allowing the vehicle to stay in contact with it even on uneven terrain. This flexibility is especially helpful in situations when the ground has abrupt height changes, slopes, or rocks. The vehicle can stay balanced and keep going without losing stability since each wheel may move independently thanks to the connection mechanism.

### 2. Excellent Obstacle-Climbing Performance

The rocker-bogie mechanism's capacity to effectively climb barriers is one of its main advantages. The front wheel can raise and pass over an impediment because of the configuration of the rocker and bogie links, while the other wheels offer support and traction. Because of this, cars with this suspension system are able to navigate obstacles that are comparatively big in relation to the size of their wheels. Because of this feature, the system is very helpful for machines that have to navigate difficult areas, robotic platforms, and exploration vehicles.



### 3. Improved Stability and Traction

The rocker-bogie system's design divides the vehicle's weight among several wheels. Each wheel can keep a greater grip on the ground since the weight is distributed equally. This increases traction and lessens the chance of slipping, particularly when the car is traveling over rocky, sandy, or loose dirt. Additionally, when driving on uneven or sloping terrain, the consistent distribution of forces lessens the likelihood of the car toppling over.

### 4. Absence of Springs Reduces Mechanical Failure

The rocker-bogie system primarily uses rigid linkages and pivot joints, compared to conventional suspension systems that mostly rely on springs and stabilizers. The likelihood of failure due to spring fatigue, breakage, or wear is decreased because there are fewer spring-based components. The system's endurance is increased by its straightforward mechanical structure, which also makes it appropriate for applications like planetary exploration missions when maintenance opportunities are limited.

#### Constraints:

#### 1. Limited Suitability for High-Speed Travel

The rocker-bogie suspension system is often not intended for high-speed movement, despite its good performance on uneven terrain. In order to enable the vehicle to safely navigate obstacles without producing undue vibration or shock, the system is designed for slow and controlled passage. Stronger impacts may be delivered to the vehicle body at higher speeds due to the absence of conventional shock-absorbing components.

#### 2. Complex Linkage Mechanism

The suspension system is made up of a number of inter related parts, including wheel assemblies, pivot joints, bogie links, and rocker arms. To guarantee appropriate mobility and load distribution, these components must cooperate with one another. Compared to traditional suspension systems, this arrangement might make the mechanism appear more complicated, and careful component alignment is required during installation.

#### 3. Higher Design and Manufacturing Effort

It takes careful planning and engineering to design and construct a rocker-bogie suspension system. To achieve the desired performance, the distribution of mass, joint placement, and link lengths must all be properly determined. Furthermore, compared to simpler suspension systems, producing the many components and precisely installing them could take more time and technical effort

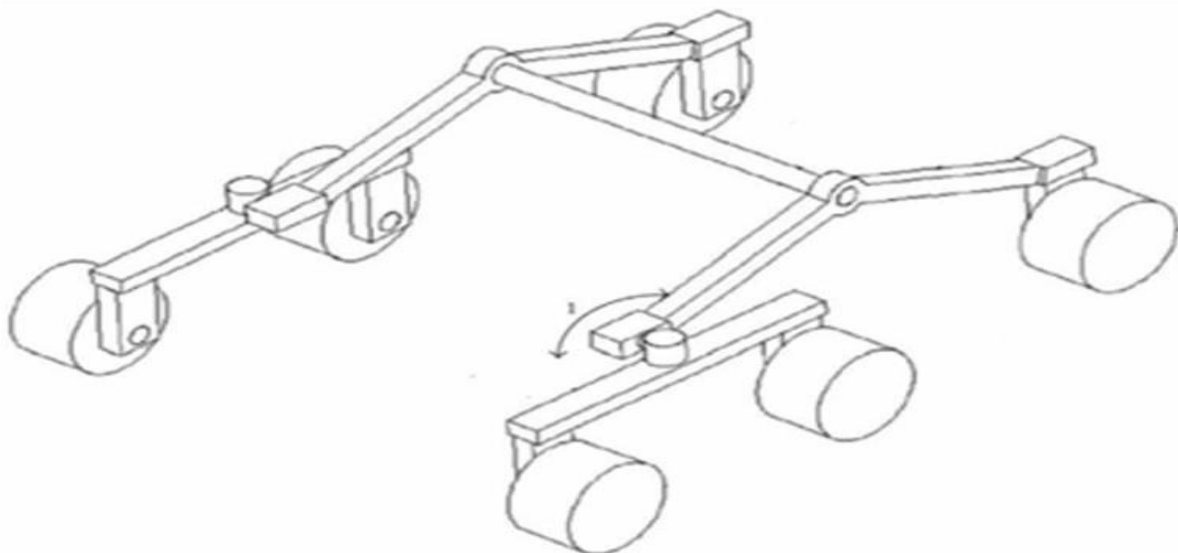

Figure 5: Line Structure



## IX. INTERNET OF THINGS

A network of physical things equipped with software, sensors, and connections that enable them to gather and share data is known as the Internet of Things (IoT). There are many different types of Internet of Things (IoT) devices, from simple sensors that monitor motion and temperature to advanced autonomous machines and robotics. By in targeting digital capabilities like sensing, communication, and oversight into physical structures and products, the Internet of Things (IoT) has the potential to completely transform operations and processes.[13]

Important features made possible by IoT include:

- Remote monitoring and control: examine and oversee systems and infrastructure from any location.
- Autonomy: self-governing devices capable of functioning without human assistance
- Optimization: use analytics on gathered data to boost productivity
- Predictive maintenance: find problems before they arise.
- Gain deeper insights by integrating different data points to enhance comprehension of the situation. Smart gadgets are Internet of Things (IoT) products that are easily incorporated into daily life, such as wearables, appliances, smart home assistants, city infrastructure, and other such objects. Large amounts of data are generated by smart devices and the Internet of Things (IoT), which can be processed to find insightful information and allow for the automation of beneficial activities (E. Michael et al., 2015)[13]

## X. FUTURE RESEARCH DIRECTIONS

It is anticipated that future studies on rocker-bogie suspension systems would concentrate on enhancing their functionality and broadening their range of uses. Adding active or semi active control mechanisms that can modify the suspension's behaviour in real time is one potential course of action. The device may retain greater stability while moving and react to shifting terrain conditions more skillfully by utilizing sensors and control algorithms. Modifying the architecture to enable vehicles with this suspension to run at comparatively higher speeds while yet retaining control and safety is another area of exploration. Additionally, researchers are investigating hybrid suspension setups that incorporate components of traditional suspension systems along with the rocker-bogie mechanism. This strategy could help strike a compromise between the advantages of both designs, offering better shock absorption while maintaining the rocker-bogie structure's superior ability to handle rough terrain. For terrain-adaptive control, artificial intelligence and machine learning approaches are also being explored. With the use of these technologies, automobiles may be able to automatically modify their movement strategy for increased stability and efficiency based on surface conditions. With these advancements in technology, the rocker-bogie suspension system may find wider uses in commercial, industrial, and robotic platforms that function in harsh conditions in addition to exploration vehicles.

## XI. CONCLUSION

Many people believe that the rocker-bogie suspension system is a mechanical solution that works well for cars that have to drive on uneven and difficult terrain. Because of its design, the wheels may stay in constant touch with the ground, increasing stability and making it possible for the car to travel over uneven, rocky, and sloping terrain. This mechanism's successful employment in multiple Mars rover missions, where it has repeatedly performed under extremely difficult climatic circumstances, has amply shown its practical reliability. These missions have demonstrated that the system is a reliable option for exploration spacecraft since it can operate for extended periods of time with little mechanical breakdown. The rocker-bogie suspension's design concepts are applicable to Earthly applications even though it was initially created for planetary exploration. The system's capacity to retain traction and balance over challenging terrain may be advantageous for off-road vehicles, such as those used in mining, agriculture, or search and rescue missions. The mechanism may be modified to fit a greater range of ground vehicles, such as autonomous robotic platforms and heavy-duty machinery, with additional study and design advancements. It is anticipated that further optimization, material selection, and control procedures would increase its effectiveness and broaden its useful applications in both industrial and scientific domains.

## REFERENCES

- [1] "Design of Rocker Bogie Mechanism" Authors: D. S. Chinchkar, S. S. Gajghate, R. N. Panchal, R. M. Shetewar, P. S. Mulik 2017



- [2] “Optimal design and kinetic analysis of a stair-climbing mobile robot with rocker-bogie mechanism”  
Authors:  
Dongmok Kima, Heeseung Honga, Hwa Soo Kimb, Jong won Kim 2012.
- [3] “New Concept-Based Six-Wheels Rocker-Bogie Robot: Design and analysis” Authors: Anish Pandeya, Ashwani  
5  
Kumara, Tarun Dhar Diwanb, Md. Ehtesham Hasana, Ra jiva Lochan Mohantya, Surjeet Singh Goura 2022
- [4] “Static structural analysis of wheel chair using a rocker bogie mechanism” Authors: S. Seralathana, Akshit Bag  
gab,  
Udhay Krishna Ganesanb, V. Hariramb, T. Micha Premkumarb, S. Padmanabhanc 2020
- [5] “System Modelling of Rocker-Bogie Mechanism for Disaster Relief.” Authors: S. F. Tohal and Zakariya  
Zainol  
2015
- [6] “Mind the obstacles: Elastic or inelastic rocker type suspension for all-terrain robots?” Authors: Angelo  
Ugenti,  
Giacomo Mantriota, Giulio Reina 2025
- [7] “Design and simulation of interplanetary lunar rover” Authors: R.S. Sravyaa, S. Sreejab, 2023
- [8] “The ExoMars rover locomotion subsystem” Authors: Nildeep Patel, Richard Slade, Jim Clemmet 2010
- [9] “Design and development of a variable ground clearance, variable wheel track self-leveling hillside vehicle  
power  
chassis” Authors: Gao Qiaominga, Gao Fenga, Tian Leib, Li Liujunb, Ding Nenggena, Xu Guoyana, Jiang Daweib 2014
- [10] “Mars Exploration Rover Mobility Assembly Design, Test and Performance” Authors: J. B. Balaram et al 2009
- [11] “Mobility System Design for the Mars Pathfinder Rover” Authors: Donald Bickler 2018
- [12] “Design and Fabrication of Rocker Bogie Mechanism for All Terrain Vehicles” Published in: International  
Journal of Mechanical Engineering
- [13] “Technological Transformations: A Comprehensive Review of AI, IoT, VR, AR, and Emerging Technologies in  
Diverse Industries” Authors: Vijayalakshmi Sajwan, Anju Bhandari Gandhi, Navdeep Kumar Chopra, Shagufta  
Praveen, Madhur Thapliyal, Uruj Jaleel, Shiv Dayal Pandey, Rajiv Kumar, Deepak Negi ,Published in 2024  
International Conference on Advances in Computing , Communication and  
Material(ICACCM) DOI :<https://doi.org/10.1109/ICACCM61117.2024.11059157>

#### Authors Details:

Study of Design and Mobility Approaches in Rocker–Bogie Suspension Systems

Sarthak Sharma (2400680140109)<sup>1</sup>, Utkarsh Nehwal (2400680140137)<sup>2</sup>, Yash Kaushik (2400680140144)<sup>3</sup>, Shrikant

(2400680140125)<sup>4</sup>, Sushant Dhasmana (2400680140128)<sup>5</sup>, Dr. Uruj Jaleel<sup>6</sup>, Dr. Satish Kumar Soni<sup>7</sup>

Student, MCA, Meerut Institute of Engineering and Technology, U.P. India<sup>1</sup>

Student, MCA, Meerut Institute of Engineering and Technology, U.P. India<sup>2</sup>

Student, MCA, Meerut Institute of Engineering and Technology, U.P. India<sup>3</sup>

Student, MCA, Meerut Institute of Engineering and Technology, U.P. India<sup>4</sup>

Student, MCA, Meerut Institute of Engineering and Technology, U.P. India<sup>5</sup>

Professor, MCA, Meerut Institute of Engineering and Technology, U.P. India<sup>6</sup>

Associate Professor, MCA, Meerut Institute of Engineering and Technology, U.P. India<sup>7</sup>